

MASTER
CATALOG

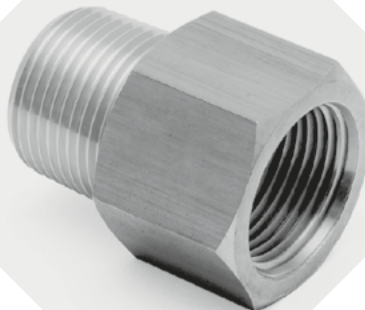

adaptall

INTERNATIONAL ADAPTER & FITTING SOLUTIONS

THREAD SPECIFICATION CHARTS

BSPB Thread Specification Chart

Dash Size	Thread Size	Threads per inch (TPI)	Male Thread O.D (mm)	Male Thread O.D (inches)	Female Thread I.D (mm)	Female Thread I.D (inches)
02	1/8	28	9.6	0.38	8.6	0.34
04	1/4	19	13	0.51	11.9	0.47
06	3/8	19	16.5	0.65	15.2	0.6
08	1/2	14	20.8	0.82	19.1	0.75
10	5/8	14	22.8	0.9	20.8	0.82
12	3/4	14	26.3	1.04	24.6	0.97
16	1	11	33.1	1.3	30.7	1.21
20	1-1/4	11	41.8	1.64	39.4	1.55
24	1-1/2	11	47.7	1.88	45.5	1.79
32	2	11	59.5	2.34	57.4	2.26
40	2-1/2	11	75.1	2.95	72.6	2.86
48	3	11	87.9	3.46	85.4	3.36

BSPT Thread Specification Chart

Dash Size	Thread Size	Threads per inch (TPI)	Male Thread O.D (mm)	Male Thread O.D (inches)	Female Thread I.D (mm)	Female Thread I.D (inches)
02	1/8	28	9.6	0.38	8.6	0.339
04	1/4	19	13.1	0.516	11.2	0.441
06	3/8	19	16.6	0.654	14.7	0.579
08	1/2	14	20.9	0.823	18.3	0.720
10	5/8	14	22.9	0.902	20.6	0.811
12	3/4	14	26.4	1.039	23.9	0.941
16	1	11	33.2	1.307	29.7	1.169
20	1-1/4	11	41.9	1.65	38.6	1.520
24	1-1/2	11	47.8	1.882	44.5	1.752
32	2	11	59.6	2.346	56.4	2.220
40	2-1/2	11	75.2	2.961	71.9	2.831
48	3	11	87.8	3.457	84.6	3.331

Metric Thread Specification Chart

Thread Callout	Thread Pitch (mm)	Male Thread O.D (mm)	Male Thread O.D (inches)	Female Thread I.D (mm)	Female Thread I.D (inches)
M8 X 1.0	1.0	8.0	0.315	6.9	0.272
M10 X 1.0	1.0	10.0	0.394	8.9	0.35
M10 X 1.5	1.5	10.0	0.394	8.4	0.331
M12 X 1.0	1.0	12.0	0.472	10.9	0.429
M12 X 1.5	1.5	12.0	0.472	10.4	0.409
M14 X 1.5	1.5	14.0	0.551	12.4	0.488
M16 X 1.5	1.5	16.0	0.63	14.4	0.567
M18 X 1.5	1.5	18.0	0.709	16.4	0.646
M20 X 1.5	1.5	20.0	0.787	18.4	0.724
M22 X 1.5	1.5	22.0	0.866	20.4	0.803
M24 X 1.5	1.5	24.0	0.945	22.4	0.882
M26 X 1.5	1.5	26.0	1.024	24.4	0.961
M27 X 2.0	2.0	27.0	1.063	24.8	0.976
M30 X 2.0	2.0	30.0	1.181	27.8	1.094
M33 X 2.0	2.0	33.0	1.299	30.8	1.213
M36 X 2.0	2.0	36.0	1.417	33.8	1.331
M42 X 2.0	2.0	42.0	1.654	39.8	1.567
M45 X 2.0	2.0	45.0	1.772	42.8	1.685
M48 X 2.0	2.0	48.0	1.89	45.8	1.803
M52 X 2.0	2.0	52.0	2.047	49.8	1.961
M60 X 2.0	2.0	60.0	2.362	57.8	2.276

24° DIN Tube - Thread Callout & Compatibility Chart

Tube Series	Tube O.D	Metric Thread Callout	Tube Nut Part #	Cutting Ring Part #	Tube Plug Part #	Tube Cap Part #
LL Extra Light Duty	4 mm	8 mm x 1.0	5201LL-04	5202LL-04	-	-
	6 mm	10 mm x 1.0	5201LL-06	5202LL-06	-	-
	8 mm	12 mm x 1.0	5201LL-08	5202LL-08	-	-
	10 mm	14 mm x 1.0	5201LL-10	5202LL-10	-	-
	12 mm	16 mm x 1.0	5201LL-12	5202LL-12	-	-
L Light Duty	6 mm	12 mm x 1.5	5201L-06	5202-06	5203L-06	5204L-06
	8 mm	14 mm x 1.5	5201L-08	5202-08	5203L-08	5204L-08
	10 mm	16 mm x 1.5	5201L-10	5202-10	5203L-10	5204L-10
	12 mm	18 mm x 1.5	5201L-12	5202-12	5203L-12	5204L-12
	15 mm	22 mm x 1.5	5201L-15	5202-15	5203L-15	5204L-15
	18 mm	26 mm x 1.5	5201L-18	5202-18	5203L-18	5204L-18
	22 mm	30 mm x 2.0	5201L-22	5202-22	5203L-22	5204L-22
	28 mm	36 mm x 2.0	5201L-28	5202-28	5203L-28	5204L-28
	35 mm	45 mm x 2.0	5201L-35	5202-35	5203L-35	5204L-35
	42 mm	52 mm x 2.0	5201L-42	5202-42	5203L-42	5204L-42
S Heavy Duty	6 mm	14 mm x 1.5	5201S-06	5202-06	5203S-06	5204S-06
	8 mm	16 mm x 1.5	5201S-08	5202-08	5203S-08	5204S-08
	10 mm	18 mm x 1.5	5201S-10	5202-10	5203S-10	5204S-10
	12 mm	20 mm x 1.5	5201S-12	5202-12	5203S-12	5204S-12
	14 mm	22 mm x 1.5	5201S-14	5202-14	5203S-14	5204S-14
	16 mm	24 mm x 1.5	5201S-16	5202-16	5203S-16	5204S-16
	20 mm	30 mm x 2.0	5201S-20	5202-20	5203S-20	5204S-20
	25 mm	36 mm x 2.0	5201S-25	5202-25	5203S-25	5204S-25
	30 mm	42 mm x 2.0	5201S-30	5202-30	5203S-30	5204S-30
	38 mm	52 mm x 2.0	5201S-38	5202-38	5203S-38	5204S-38

TUTORIALS

TERMS AND DEFINITIONS	4
SEALING METHODS & TECHNOLOGIES	6
HOW TO ID BRITISH THREADS & FITTINGS	10
HOW TO ID METRIC THREADS & FITTINGS	12
HOW TO INSTALL FITTINGS & ADAPTERS	16

PRODUCTS

FEATURED

THREAD GAUGES	23
KITS	24
STOCKING PROGRAMS	28

STEEL

BANJO ADAPTERS	29
24° DIN TUBE ADAPTERS/FITTINGS	31
INTERNATIONAL ADAPTERS	44

STAINLESS STEEL

24° DIN TUBE ADAPTERS/FITTINGS	76
INTERNATIONAL ADAPTERS	81

BRASS

COMPRESSION, POLYTUBE & PUSH TO CONNECT	87
INTERNATIONAL ADAPTERS	90

MALLEABLE IRON

BSP PIPE FITTINGS	94
-----------------------------------	----

QUICK REFERENCE

STRAIGHT MALE X MALE	96
STRAIGHT MALE X FEMALE	99
STRAIGHT FEMALE X FEMALE	101
STRAIGHT OTHER/MISC	102
45° ELBOWS	103
90° ELBOWS	104
PLUGS & CAPS	107
TEES & CROSSES	108
COMPONENTS	111

ABOUT

COMPLIANCES	112
FITTING & PLATING STANDARDS	112
MATERIAL SPECS	112
WARRANTY, TERMS & CONDITIONS	112

VIDEOS

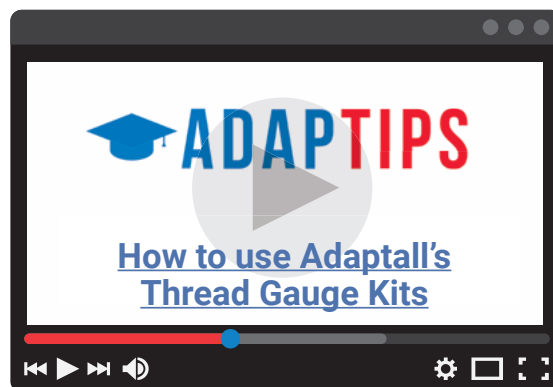

REACH US

EMAIL sales@adaptall.com

TELEPHONE 1.800.463.8134

WEB adaptall.com

TUTORIALS TERMS & DEFINITIONS

TUTORIALS

Metric Fittings vs. Metric Threads

The terminology used to describe the majority of foreign threaded fittings can be confusing to some. Metric fitting is a loose term describing fitting bodies with foreign threads including BSP, DIN, JIS, Kobelco, Komatsu, and Metric, even though some of these are based in imperial or "inch" dimensions. Metric threads, however, refers to a specific type of foreign thread.

FEATURED

Part Numbering and Hose/Tube Side vs. Port Side

When fittings are classified or part-numbers displayed, the first group of numbers indicates the part series or group, while the dash sizes indicate the thread sizes. The sizes are usually displayed tube or hose side first, meaning that the end connecting to a hose or tube is typically listed as the first dash size. The port side is usually listed as the second dash size.

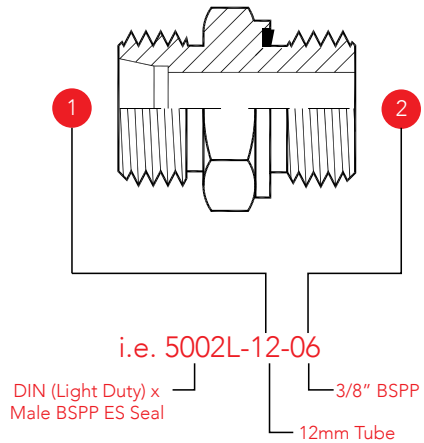

STEEL

STAINLESS STEEL

Thread Form vs. Thread Pitch vs Threads per Inch

When identifying fittings, another important factor to look at is thread form and thread pitch, or threads per inch in other cases. Thread form refers to the angle (in degrees) that exists between adjacent flanks of a thread. This is a difficult method of identification and requires a profile projector to be certain. Thread pitch however, refers to the distance measured between adjacent thread crests, and is typically used when measuring Metric threads.

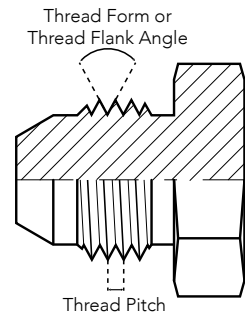

BRASS

On the other hand, threads per inch or "TPI" is often used, which counts the number of threads over one inch of distance. In some cases, calculations are required i.e. 5.5 threads counted over a 1/2" would mean there are 11 threads over 1". It is recommended to use a thread gauge as it provides the most accurate form of identification.

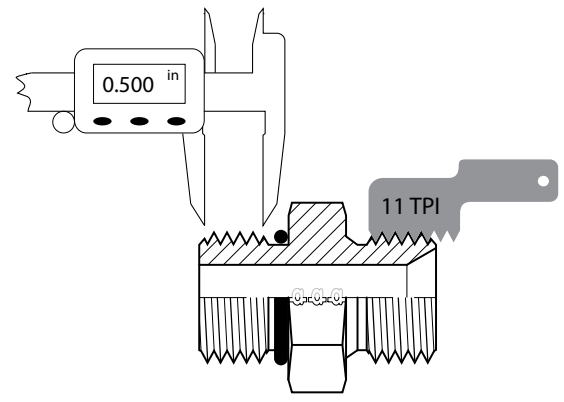

MEALLEABLE IRON

QUICK REFERENCE

ABOUT

Thread Type	Thread Flank Angle	TPI vs mm Pitch
BSPP	55°	TPI
BSPT	55°	TPI
JIC	60°	TPI
JIS	55°	TPI
KOBELCO	60°	mm Pitch
KOMATSU	60°	mm Pitch
METRIC 60°	60°	mm Pitch
METRIC DIN TUBE	60°	mm Pitch
NPT	60°	TPI
ORB	60°	TPI
ORFS	60°	TPI

Major vs Minor Thread Diameter

All threads have what's known as a Major Diameter, and a Minor Diameter. Major Diameter is the measurement from thread crest to thread crest, while Minor Diameter is measured from thread root to thread root. With male threads, the Major Diameter (our outer diameter, O.D for short) of the thread could be measured and compared to a chart of various thread types and known Major Diameters/O.D's for identification purposes. For female threads, instead compare the Minor Diameter (also known as internal diameter, or I.D for short). You can compare your caliper readings to published specifications in order to find the closest match.

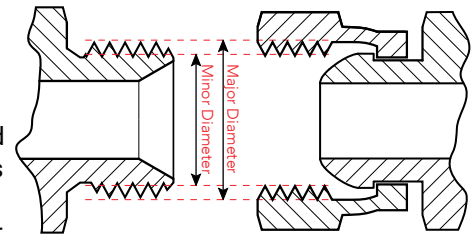

Nominal Size vs Dash Size

The 'nominal size' is an engineering term for a non-specific reference or trade size of a part (such as a pipe) that is for identification purposes only and may not match any exact dimension. For example, a 2" nominal pipe has neither a 2" I.D or O.D, but an O.D of 2.375" and an I.D range of 0.065" to 0.436" depending on the schedule. However, a 2" NPT thread would be applicable to all of these because of the common nominal sizing based on approximate outer diameter.

The nominal area of reference depends on the fitting or thread type; this could be based on the thread O.D, thread O.D & pitch (callout), hose/tube/pipe I.D or O.D, and/or tube class. The nominal size is in either inches or mm (millimeters), and the methodology of which usually remains consistent from one vendor to the next. Here are some examples:

Thread Type	Nominal Size Based On	Nominal Size Example
BSPP	Hose/tube/pipe I.D (inches)	1/4", 3/8", 1/2" etc
BSPT	Hose/tube/pipe I.D (inches)	1/4", 3/8", 1/2" etc
DIN Metric	Pressure class (LL, L, or S) & tube O.D in mm (sometimes thread size &/or pitch included)	L08, L08 14mm, L08-14X1.5, etc. (mm)
JIC	Hose/tube I.D (inches)	1/4", 3/8", 1/2" etc
JIS	Hose/tube I.D (inches)	1/4", 3/8", 1/2" etc
Kobelco	Tube O.D & thread O.D (pressure class always L and is pitch always 1.5)	22-30 (22mm tube, 30x1.5 thread)
Komatsu	Thread O.D (mm) - always a 1.5 pitch	14mm
Metric	Thread O.D (mm) – sometimes thread pitch is included especially if non-standard	14mm, 14X1.5, 14X1.0, etc
NPT	Pipe O.D (inches)	1/4", 3/8", 1/2" etc
ORB	Hose/tube I.D (inches)	1/4", 3/8", 1/2" etc

Once the nominal size of the thread is determined, the nominal size needs to be converted to a 'dash size' for ordering. A dash size is simply a 2-digit reference for sizing a hose, tube, pipe or fitting, and is displayed as a fraction of 16. Each size increments by 1/16" if the nominal sizing is based on inches, then drop the /16. For example, 1/2" converts to 8/16" which is the same as a -08 (dash zero eight).

However, if the nominal size is metric (mm) based, then no calculation is required - simply drop the mm. For example, a 30mm thread has a dash of -30 (dash thirty). If the thread pitch is nonstandard for that Metric thread, then the thread pitch is sometimes displayed in the dash size i.e. 30x1.5 (standard thread pitch for 30mm is 2.0).

Inch Fraction	Dash Size
1/8"	02
3/16"	03
1/4"	04
5/16"	05
3/8"	06
7/16"	07
1/2"	08
5/8"	10
3/4"	12
7/8"	14
1"	16
1-1/4"	20
1-1/2"	24
2"	32
2-1/2"	40
3"	48

Metric Thread (O.D)	Standard Thread Pitch (mm)
6mm	1.0
8mm	1.0
10mm	1.0
12mm	1.5
14mm	1.5
16mm	1.5
18mm	1.5
20mm	1.5
22mm	1.5
24mm	1.5
26mm	1.5
27mm	2.0
30mm	2.0
33mm	2.0
36mm	2.0
42mm	2.0
45mm	2.0
52mm	2.0

TUTORIALS SEALING METHODS

Port Fittings - Tapered vs. Parallel Threads

If dealing with a port fitting, the first step towards thread identification is to determine whether the thread is parallel or tapered. Parallel means the thread walls are straight; while tapered means the thread walls, if continued lengthwise, would eventually meet. A seal must be used for all parallel fittings in port application, with the exception of Cutting Face fittings, however these are fairly rare. It is important to note that BSPT (British Standard Pipe – Tapered) can seal into a parallel BSP port, and Metric Tapered threads are capable of sealing into a parallel Metric port.

This first step will help you eliminate a number of possible thread types, as well as possibly reveal the method of sealing. For a parallel thread in port application, the fitting will usually seal at the top of the thread by means of an O-ring or seal. With a tapered thread, the fitting typically seals via metal-to-metal wedging of the threads. A thread sealant is applied prior to installation to reduce instances of leakage on tapered threads.

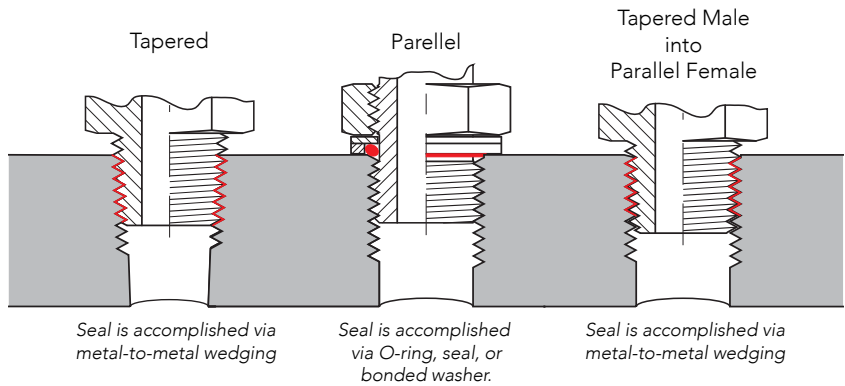

Tapered Male X Tapered Female <i>Seals via thread wedging</i>	Parallel Male X Parallel Female <i>Seals via O-ring/Bonded Seal</i>	Tapered Male X Parallel Female <i>Seals via thread wedging</i>
BSPT	BSPP	M-BSPT X F-BSPP (port/ fixed female only)
Metric Taper	Metric	M-Metric Taper X F-Metric (port/ fixed female only)
NPT	SAE O-ring Boss	

TUTORIALS

FEATURED

STEEL

STAINLESS STEEL

BRASS

MEALLEABLE IRON

QUICK REFERENCE

ABOUT

Flared Seat vs Cone Seat vs Ball Seat

The ability to properly identify seats, chamfers, and their corresponding angles can also be a benefit to overall fitting identification. Flared seats refer to the protruding “nose cone” on a male thread, but also the corresponding inverted flare in a female thread. Chamfer is a term assigned to the internally bevelled sealing surface inside of a male thread, which mates with a female cone seat and is typically angled at 30°/60°. Please note the language is interchangeable i.e. Chamfers can also be referred to as Inverted Flared Seats and vice versa.

Ball seats however refer to the spherical sealing surface inside a female thread (swivel only) that seals with the chamfer on the inside of a male thread. These sealing systems all share a common trait in that there is a metal-to-metal seal created where the male and female surfaces contact (not including the threads).

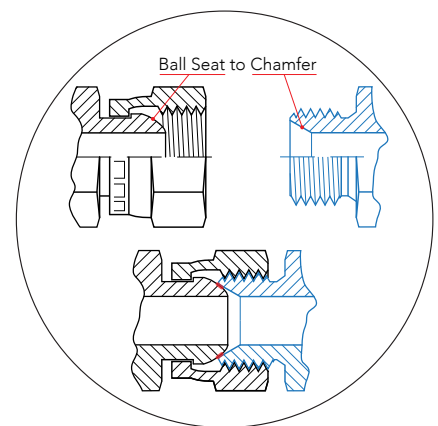
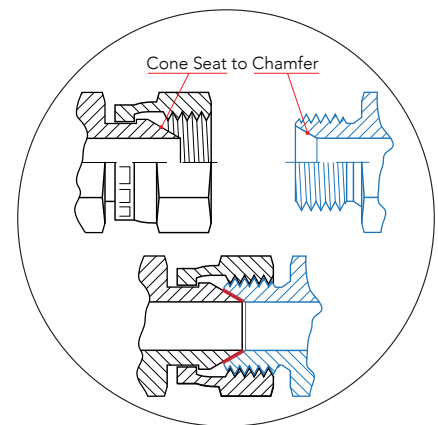
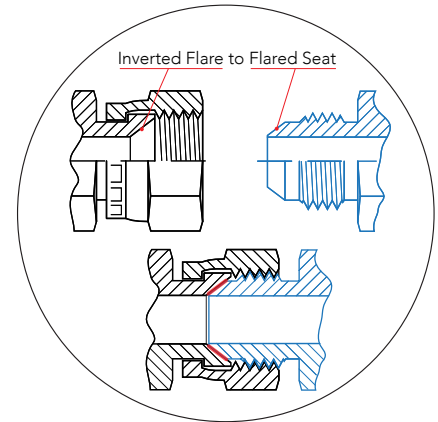

Flared Seat	Cone Seat	Ball Seat
JIC	BSPP	Metric (female swivel)
JIS	DIN DKO Metric	NPSM (brass ball seat)
Komatsu	NPT (NPSM female swivel)	
Metric Chinese GB 37/74		

TUTORIALS SEALING METHODS

TUTORIALS

FEATURED

STEEL

STAINLESS STEEL

BRASS

MEALLEABLE IRON QUICK REFERENCE

ABOUT

Face Seal vs Boss Seal

Both Face Sealing and Boss Sealing fitting types utilize an encapsulated O-ring in order to create a seal. The difference is that Face Seal fittings have the O-ring located in the grooved area at the end of the male thread, while Boss Seal fittings have the O-ring located at the base of the male thread. The corresponding female Face Seal fitting has a flat sealing surface that engages the O-ring in the male fitting and compresses it as the fittings are threaded together and creates a seal. Boss Seal female fittings on the other hand have a grooved "boss" before the first thread that acts to encapsulate the O-ring on the male thread thereby creating a seal.

The most popular Face Seal fitting type is O-ring Face Seal, however this can be easily confused with HIAB or GB Face Seal fittings which also utilize Face Sealing. The most popular Boss Seal fitting type is O-ring Boss, however this can be easily confused with Metric ISO 6141 which utilizes Metric threads and a Boss Seal.

Face Seal Fitting Types	Boss Seal Fitting Types
O-ring Face Seal	SAE O-ring Boss
HIAB	Metric ISO 6141
Metric Chinese GB Face Seal	

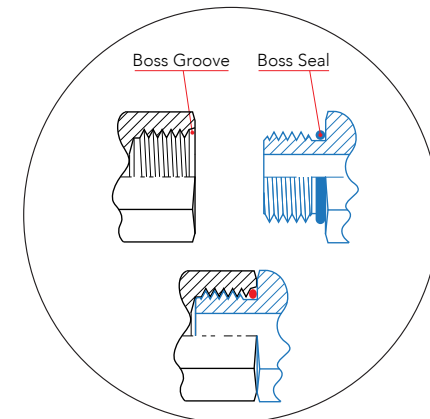
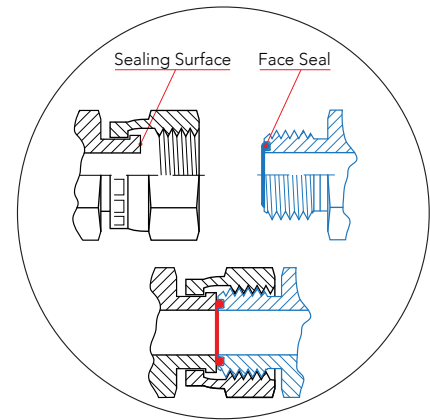

Metal to Metal Sealing

One of the rarer methods of sealing a fitting in port is Metal to Metal Sealing, also known as Cutting Face or Type B. This design creates a seal by means of a sharp "cutting face" at the base of the male thread that cuts into the flats or "spotface" surrounding the port when the fitting is threaded and tightened.

Cutting Face Type B is available in BSPP (ISO 1179-4) and Metric (ISO 9974- 3), although it is commonly mis-identified as regular BSPP or Metric port fitting with the seal missing. Look for a raised outer section on the male fitting where the bonded washer or seal would go; if it exists this indicates the fitting is Cutting Face.

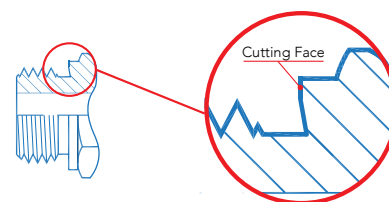
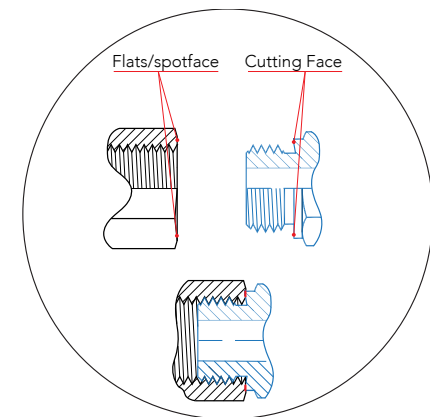

24° DIN Tube Fittings

DIN fittings have a 24° tapered throat angle that exists inside the male threads. To achieve a tube connection, a tube nut is tightened over the metric threads (hardened pre-assembly fitting bodies are recommended for installation) forcing a ferrule or cutting ring to grip the tube. By having the nut securely fastened to the tube fitting, both compress the cutting ring which holds the assembly in place and creates a seal. This sealing style also includes Kobelco fittings which are essentially an L-series Metric thread with a 1.5mm thread pitch in all sizes.

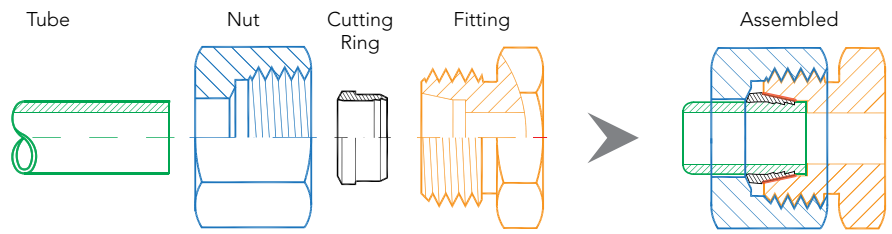

DIN 24° fittings and accessories belong to one of three **Pressure Classes**: LL series for Extra Light duty, L series for Light duty, and S series for Heavy duty applications.

24° Metric Compression Fitting Types

- DIN Tube
- Kobelco
- Japan Steel Works (JSW)
- French GAZ

Sealing Surface Angles

The angle sealing surfaces on fittings can be used to aid in fitting identification. There are a few ways to identify this angle, such as by means of angle gauge or by profile projector.

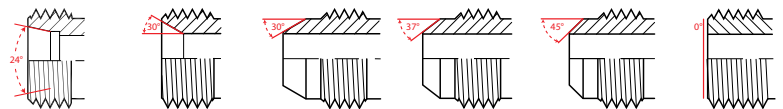

24° Internal Chamfer	30° Internal Chamfer	30° External Flare	37° External Flare	45° External Flare	None/Flat
DIN Metric	BSPP	Komatsu	JIC	SAE 45°	ORFS
Kobelco	DIN 7631 Metric	JIS	GB Metric (Chinese)	AN 45°	ORB
JSW	NPTF/ NPSM				ISO 6149 Metric
French GAZ					BSPP & Metric Port
					Chinese Face Seal Metric
					BSPT

TUTORIALS HOW TO ID BRITISH THREADS & FITTINGS

British Standard Pipe fittings are among the most popular of all foreign threads in the world today. These threads come in two versions: parallel (BSPP), and tapered (BSPT). The thread flank angle for both tapered and parallel British threads is 55°. Although BSP is a foreign thread, it isn't actually metric. This is why it comes in Imperial sizes: 1/8, 1/4, 1/2, 3/4, etc.

BSP parallel (BSPP) threads commonly seal via a 30° chamfer on the male thread to a 30° cone seat inside the female thread (swivel only). If it is a port application, an O-ring and washer, Elastomeric seal or a bonded washer are needed to achieve a proper seal for parallel threads. For tapered BSP threads (BSPT), a seal is accomplished via thread wedging with additional support from thread dope or tape. As previously mentioned, it is possible for a male BSPT (tapered) to thread into a female BSPP (parallel), so long as the female thread is fixed and not swivel (this is because the recessed cone seat could interfere with clearance). To identify a BSPP fitting complete the following steps:

- 1) Confirm the thread is parallel or tapered.
- 2) Determine the threads per inch (TPI) count using a thread gauge or calipers.
- 3) Determine the thread O.D (male thread) or I.D (female thread) using calipers.
- 4) Find a match on the adjacent chart by combining your O.D or I.D measurement with the TPI you measured.
- 5) If a seal or angled sealing surface exists, use it to identify which specific type of British fitting it is on the chart to the right.
- 6) To simplify this process, try Adaptall's TKG (thread gauge kit). See page 23.

Use the diagram to your right to confirm what type of British fitting you have. Use caution as "multi-purpose fittings" exist that accommodate 2 or more sealing styles in one fitting (such as Adaptall's 9005ES series that can be used for BSPP port or swivel connection).

BSPP Thread Specification Chart

Dash Size	Nom. Size	Threads per inch (TPI)	Male Thread O.D (mm)	Male Thread O.D (inches)	Female Thread I.D (mm)	Female Thread I.D (inches)
02	1/8	28	9.6	0.38	8.6	0.34
04	1/4	19	13	0.51	11.9	0.47
06	3/8	19	16.5	0.65	15.2	0.6
08	1/2	14	20.8	0.82	19.1	0.75
10	5/8	14	22.8	0.9	20.8	0.82
12	3/4	14	26.3	1.04	24.6	0.97
16	1	11	33.1	1.3	30.7	1.21
20	1-1/4	11	41.8	1.64	39.4	1.55
24	1-1/2	11	47.7	1.88	45.5	1.79
32	2	11	59.5	2.34	57.4	2.26
40	2-1/2	11	75.1	2.95	72.6	2.86
48	3	11	87.9	3.46	85.4	3.36

BSPP Threads and Sealing Methods

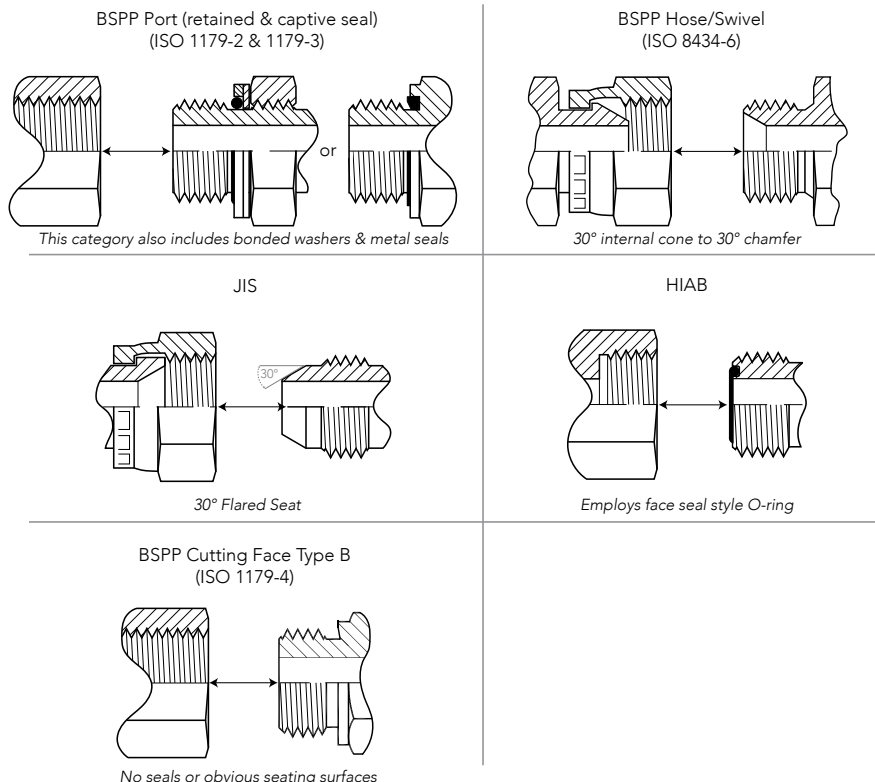

Japanese (JIS) tapered and parallel fittings

Japanese (JIS) tapered and parallel fittings are identical to British standard pipe threads, and are therefore considered to be in the 'British Fitting' group. The only difference is that parallel JIS threads have a 30° cone seat on the male end, and a 30° flared seat on the female ends. JIS tapered threads are identical to BSPT threads. Please refer to the BSPP and BSPT thread charts above for details.

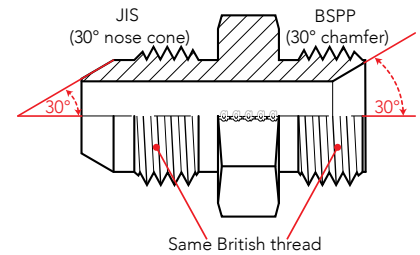

British tapered threads (BSPT)

For British tapered threads (BSPT) caution should be taken as the most common tapered fitting in North America is NPT. The easiest way to distinguish any tapered fitting type from NPT is to verify if a chamfered sealing surface exists. If it does the fitting is most likely NPT. If not, it is either BSPT or Metric Taper (Metric Taper is far less common).

To verify the thread is BSPT, you would undergo the same steps as for a parallel British thread. First, verify the number of threads per inch. Second, measure the O.D. at the 3-4th thread from the end of the fitting. You can cross-reference your measurements to the following chart in order to verify the fitting is BSPT.

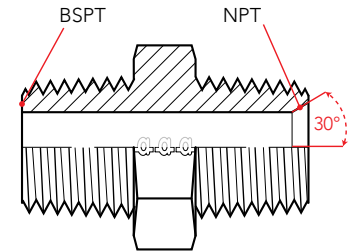

BSPT Thread Specification Chart

Dash Size	Nom. Thread Size	Threads per inch (TPI)	Male Thread O.D (mm)	Male Thread O.D (inches)	Female Thread I.D (mm)	Female Thread I.D (inches)
02	1/8	28	9.6	0.38	8.6	0.339
04	1/4	19	13.1	0.516	11.2	0.441
06	3/8	19	16.6	0.654	14.7	0.579
08	1/2	14	20.9	0.823	18.3	0.720
10	5/8	14	22.9	0.902	20.6	0.811
12	3/4	14	26.4	1.039	23.9	0.941
16	1	11	33.2	1.307	29.7	1.169
20	1-1/4	11	41.9	1.65	38.6	1.520
24	1-1/2	11	47.8	1.882	44.5	1.752
32	2	11	59.6	2.346	56.4	2.220
40	2-1/2	11	75.2	2.961	71.9	2.831
48	3	11	87.8	3.457	84.6	3.331

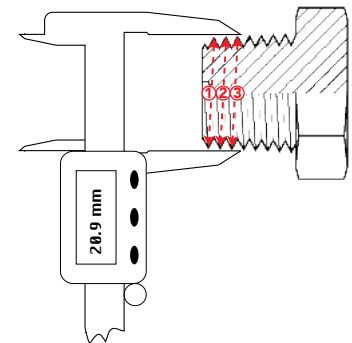

NOTE: It is a fairly common mistake to identify a BSPT (tapered) as an NPT. Always remember that NPT fittings have a 30° chamfered sealing surface while BSPT do not. Always use a thread gauge to be certain.

TUTORIALS HOW TO ID METRIC THREADS & FITTINGS

Metric threads share many characteristics with British threads, so caution must be taken when attempting to differentiate the two. First, if the Metric thread is DIN 7631 it will have a 30° chamfer on the male thread, the same as a BSPP male. For fittings in port application, Metric fittings (ISO 9974) also mimic BSPP (ISO 1179) stud ends with the only difference being the threads. BSPT fittings closely resemble Metric taper fittings, although Metric taper is far less common. There are also variations of the sealing surfaces among different Metric fitting types that can create difficulty when attempting to identify.

For Metric parallel threads, taking a caliper reading of the threads outer diameter in millimetres (mm) will give a reading of the exact thread size but not the thread pitch. For example, a caliper reading of 12.03mm indicates it is very likely a 12mm thread. We still do not know however if it is 1.0 or 1.5 thread pitch (or some other pitch).

These steps should be taken in order to ensure you have successfully identified the proper Metric thread:

1. Identify if the thread is parallel or tapered
2. Determine the thread pitch in mm using a thread gauge or calipers (typically 1.0, 1.5, or 2.0, but other sizes do exist)
3. Determine the thread O.D (male thread) or I.D (female thread) using calipers.
4. Find the closest match on the adjacent chart (thread O.D and pitch combine into a "thread callout" such as M12 x 1.5 indicating a 12mm O.D with 1.5mm pitch)
5. If a seal or angled sealing surface exists, use it to identify which specific type of Metric fitting it is on next page's chart.
- 6) To simplify this process, try Adaptall's TKG (thread gauge kit). See page 23.

Metric Thread Specification Chart

Thread Callout	Thread Pitch (mm)	Male Thread O.D (mm)	Male Thread O.D (inches)	Female Thread I.D (mm)	Female Thread I.D (inches)
M8 X 1.0	1.0	8.0	0.315	6.9	0.272
M10 X 1.0	1.0	10.0	0.394	8.9	0.35
M10 X 1.5	1.5	10.0	0.394	8.4	0.331
M12 X 1.0	1.0	12.0	0.472	10.9	0.429
M12 X 1.5	1.5	12.0	0.472	10.4	0.409
M14 X 1.5	1.5	14.0	0.551	12.4	0.488
M16 X 1.5	1.5	16.0	0.63	14.4	0.567
M18 X 1.5	1.5	18.0	0.709	16.4	0.646
M20 X 1.5	1.5	20.0	0.787	18.4	0.724
M22 X 1.5	1.5	22.0	0.866	20.4	0.803
M24 X 1.5	1.5	24.0	0.945	22.4	0.882
M26 X 1.5	1.5	26.0	1.024	24.4	0.961
M27 X 2.0	2.0	27.0	1.063	24.8	0.976
M30 X 2.0	2.0	30.0	1.181	27.8	1.094
M33 X 2.0	2.0	33.0	1.299	30.8	1.213
M36 X 2.0	2.0	36.0	1.417	33.8	1.331
M42 X 2.0	2.0	42.0	1.654	39.8	1.567
M45 X 2.0	2.0	45.0	1.772	42.8	1.685
M48 X 2.0	2.0	48.0	1.89	45.8	1.803
M52 X 2.0	2.0	52.0	2.047	49.8	1.961
M60 X 2.0	2.0	60.0	2.362	57.8	2.276

TUTORIALS HOW TO ID METRIC THREADS & FITTINGS

If you have identified the fitting as having a Metric thread you still need to determine what version or style of Metric Fitting it is.

Metric Threads and Methods of Sealing

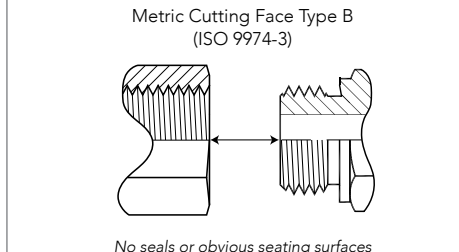
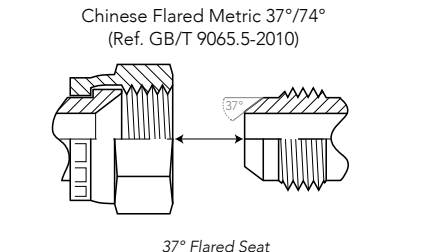
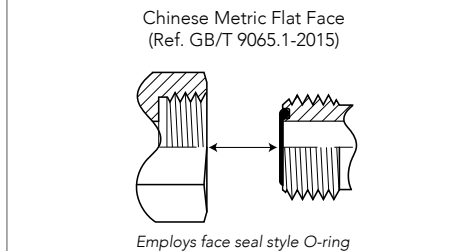
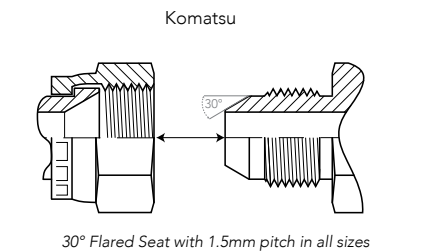
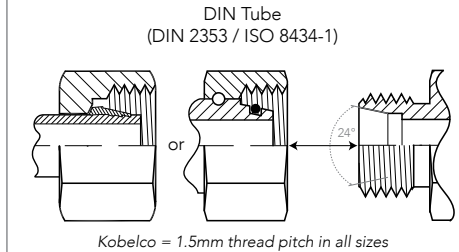
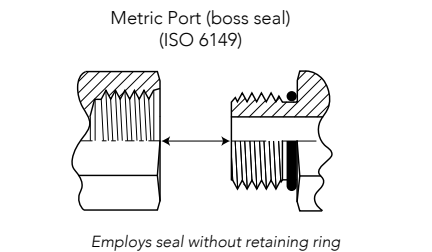
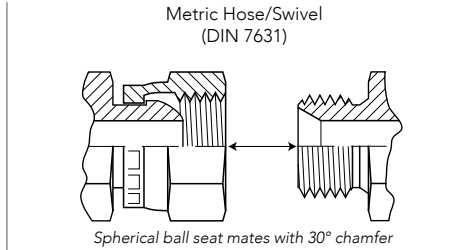
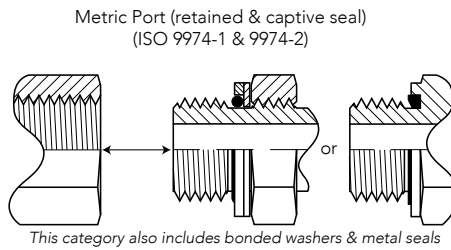

TUTORIALS

FEATURED

STEEL

STAINLESS STEEL

BRASS

MEALLEABLE IRON QUICK REFERENCE

ABOUT

TUTORIALS HOW TO ID METRIC THREADS & FITTINGS

DIN Tube Fittings

As previously mentioned, DIN tube fittings have a 24° tapered throat on the inside of the male fitting which should clearly identify it as being DIN if a Metric thread has also been identified. To identify which series and tube size the fitting belongs to, examine the tube nut: most manufacturers indicate the tube series and size on the nut itself. The system used for this marking combines TUBE SERIES with TUBE O.D, for example: the size of 15mm tube in the L series is shortened to L15.

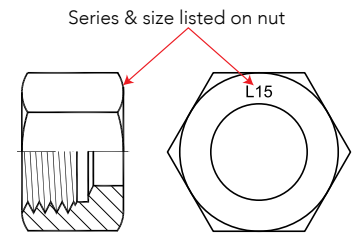

If the series and size is not listed on the part, match the tube O.D with the metric thread callout (thread size and thread pitch in mm) on the chart provided to find the corresponding tube series and size:

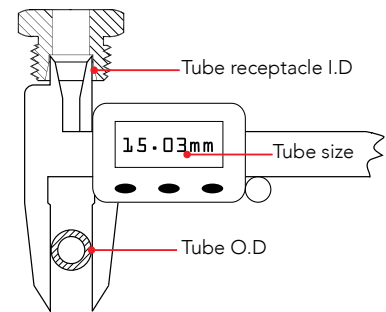

DIN Tube Extra Light Duty (LL), Light Duty (L) & Heavy Duty (S) Component Compatibility Chart

Tube Series	Tube O.D	Metric Thread Callout	Tube Nut Part #	Cutting Ring Part #	Tube Plug Part #	Tube Cap Part #
LL Extra Light Duty	4 mm	8 mm x 1.0	5201LL-04	5202LL-04	-	-
	6 mm	10 mm x 1.0	5201LL-06	5202LL-06	-	-
	8 mm	12 mm x 1.0	5201LL-08	5202LL-08	-	-
	10 mm	14 mm x 1.0	5201LL-10	5202LL-10	-	-
	12 mm	16 mm x 1.0	5201LL-12	5202LL-12	-	-
L Light Duty	6 mm	12 mm x 1.5	5201L-06	5202-06	5203L-06	5204L-06
	8 mm	14 mm x 1.5	5201L-08	5202-08	5203L-08	5204L-08
	10 mm	16 mm x 1.5	5201L-10	5202-10	5203L-10	5204L-10
	12 mm	18 mm x 1.5	5201L-12	5202-12	5203L-12	5204L-12
	15 mm	22 mm x 1.5	5201L-15	5202-15	5203L-15	5204L-15
	18 mm	26 mm x 1.5	5201L-18	5202-18	5203L-18	5204L-18
	22 mm	30 mm x 2.0	5201L-22	5202-22	5203L-22	5204L-22
	28 mm	36 mm x 2.0	5201L-28	5202-28	5203L-28	5204L-28
	35 mm	45 mm x 2.0	5201L-35	5202-35	5203L-35	5204L-35
	42 mm	52 mm x 2.0	5201L-42	5202-42	5203L-42	5204L-42
S Heavy Duty	6 mm	14 mm x 1.5	5201S-06	5202-06	5203S-06	5204S-06
	8 mm	16 mm x 1.5	5201S-08	5202-08	5203S-08	5204S-08
	10 mm	18 mm x 1.5	5201S-10	5202-10	5203S-10	5204S-10
	12 mm	20 mm x 1.5	5201S-12	5202-12	5203S-12	5204S-12
	14 mm	22 mm x 1.5	5201S-14	5202-14	5203S-14	5204S-14
	16 mm	24 mm x 1.5	5201S-16	5202-16	5203S-16	5204S-16
	20 mm	30 mm x 2.0	5201S-20	5202-20	5203S-20	5204S-20
	25 mm	36 mm x 2.0	5201S-25	5202-25	5203S-25	5204S-25
	30 mm	42 mm x 2.0	5201S-30	5202-30	5203S-30	5204S-30
38 mm	52 mm x 2.0	5201S-38	5202-38	5203S-38	5204S-38	

TUTORIALS HOW TO ID METRIC THREADS & FITTINGS

Kobelco Fittings

Kobelco fittings are essentially the same as 24° DIN Metric tube fittings however all sizes of Kobelco threads have a 1.5mm pitch. All tube accessories for Kobelco fittings belong to the L series and are fully interchangeable. However, the only sizes that are truly unique to Kobelco are in the list below.

Kobelco Component Compatibility Chart

Tube Series	Tube O.D	Metric Thread Callout	Tube Nut Part #	Cutting Ring Part #	Tube Plug Part #	Tube Cap Part #
L	22 mm	30 mm x 1.5	5201L-22-30X1.5	5202-22	9248-22-30	9249-22-30
	28 mm	36 mm x 1.5	5201L-28-36X1.5	5202-28	9248-28-36	9249-28-36
	35 mm	45 mm x 1.5	5201L-35-45X1.5	5202-35	9248-35-45	9249-35-45

Komatsu Fittings

Komatsu fittings have a 1.5mm thread pitch in all sizes and seals via a 30°/60° cone seat. If you identify a Metric thread with a nose cone be very careful to distinguish if it's actually a 30°/60° (Komatsu) cone seat instead of 37°/74° (GB Chinese).

37°/74° and Flat Face Chinese Metric Fittings

These fittings are becoming more commonly exported out of China on heavy equipment using Chinese standards. What defines these standards are that they both utilise North American styles of sealing but with Metric threads. This includes O-ring face seal (ORFS) and 37° flared seat (JIC) sealing methods, however the UN and SAE threads are replaced with Metric and do not follow traditional thread pitches in all sizes.

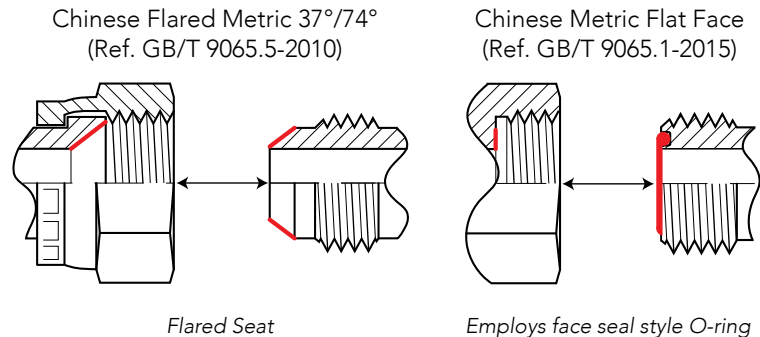

Metric Taper Threads

If you have a Metric tapered thread, one would undergo the same initial steps for identification of thread pitch as a parallel Metric thread. Also similar to parallel Metric threads is that an O.D measurement will reveal the actual thread size (i.e. 18.01mm measurement means the thread is likely M18). However, to do this accurately with Tapered Metric threads one must measure the O.D at the third row of threads from the end of the fitting.

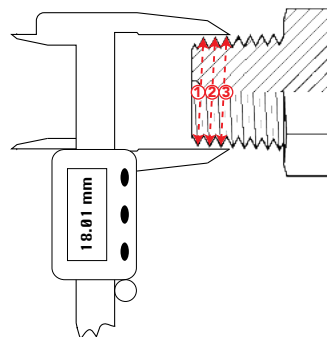

TUTORIALS HOW TO INSTALL FITTINGS & ADAPTERS

TUTORIALS

FEATURED

STEEL

STAINLESS STEEL

BRASS

MEALLEABLE IRON

QUICK REFERENCE

ABOUT

Installation of Non-Adjustable & Straight Port Fittings

1. Observe unassembled parts, especially threads and bore to ensure it is free of foreign material, burrs, nicks, etc.
2. Make sure compound/material and hardness of O-ring are suitable for the medium type and temperature.
3. Observe O-ring for nicks or cuts and replace if any found. Never use a damaged O-ring!
4. Install O-ring on male thread and make sure the O-ring is not cocked or twisted. Abut O-ring to the base of the thread.
5. Lubricate the O-ring with a light coat of the system's fluid or suitable lubricant.
6. Install retaining ring over the O-ring (if included) and ensure O-ring is seated inside the retaining ring evenly.
7. Screw and tighten the fitting or adapter into the port using suggested torque values.
8. Inspect the assembly to ensure the O-ring is properly seated and there are no leaks.

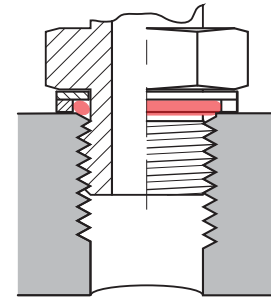

O-ring is properly installed and fitting torqued

Installation of Adjustable Port Fittings

1. Following the above steps (Non-Adjustable & Straight Port Fittings) and stop after step 6.
2. Back off the adjustable nut and backup washer as far back as possible, ensuring the threads are fully exposed.
3. Thread fitting into the port until the seal comes into full contact with the spotface (do not overtighten).
4. If installing an elbow, align the direction of the hose or tube end to a desirable orientation by unscrewing the fitting, but be sure not to go past one full turn.
5. Utilizing 2 wrenches (one being a torque wrench), hold the fitting in position with one wrench while tightening the adjustable nut with the torque wrench. Use suggested torque values.
6. Inspect the assembly to ensure that the O-ring & retaining ring are properly seated, and that there are no leaks.
7. If a crowsfoot is used with a torque wrench, adjustments might need to be made to the torque settings otherwise overtightening could occur. Consult your manufacturer for instructions.

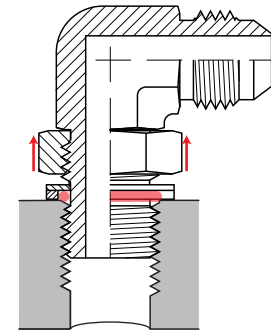

Adjustable nut and washer are backed all the way off. Fitting is threaded in until seal is touching the port. Fitting is not oriented yet.

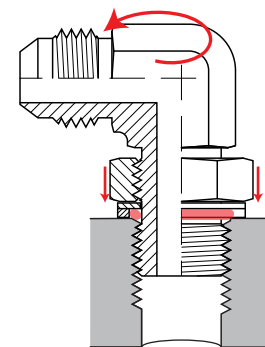

Orient the fitting to face direction of hose or tube by loosening the fitting, but not more than one turn. Then torque the adjustable nut to suggested setting while holding the fitting body.

TUTORIALS HOW TO INSTALL FITTINGS & ADAPTERS

BSPP Port – Torque Settings

	Dash Size	Inch Thread Size-TPI	Retaining Ring & O-Ring		ED/ES Seal		Bonded Washer	Cutting Face	Banjo	
			Straight (Nm)	Adjustable (Nm)	Straight (Nm)	Plugs (Nm)	Straight (Nm)	Straight (Nm)	With Copper Washers	With Soft Seals
Light Series (L)	02	1/8-28	18	18	18	13	9	18	18	18
	04	1/4-19	35	35	35	30	35	35	45	40
	06	3/8-19	70	70	70	60	45	70	70	65
	08	1/2-14	90	90	90	80	65	140	120	90
	12	3/4-14	180	180	180	140	90	180	230	125
	16	1-11	310	310	310	200	150	330	320	
	20	1-1/4-11	450	450	450	400	240	540	540	
	24	1-1/2-11	540	540	540	450	290	630	700	
Heavy Series (S)	04	1/4-19	40	40	40		35	55	45	40
	06	3/8-19	60	60	80		45	90	70	65
	08	1/2-14	90	90	115		65	140	120	90
	12	3/4-14	180	180	180		90	270	230	125
	16	1-11	310	310	310		150	340	320	
	20	1-1/4-11	450	450	450		240	540	540	
	24	1-1/2-11	540	540	540		290	700	700	

Please note:

- All torque values are intended for steel fittings.
- For Brass fittings and adapters use 65 % of the torque values.
- For Stainless steel fittings and adapters, use 5% higher value than listed and lubricate threads.

TUTORIALS HOW TO INSTALL FITTINGS & ADAPTERS

Metric Port – Torque Settings

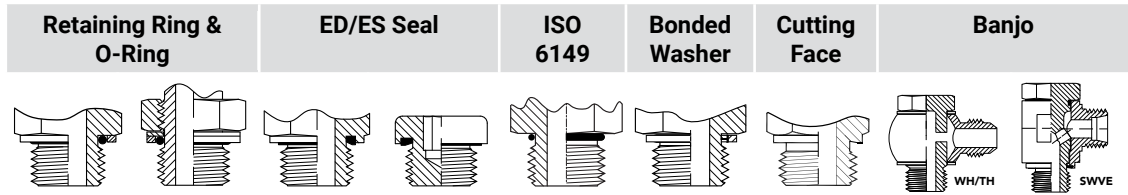

	Thread Size mm	Straight (Nm)	Adjustable (Nm)	Straight (Nm)	Plugs (Nm)	Straight & Adjustable (Nm)	Straight (Nm)	Straight (Nm)	With Copper Washers	With Soft Seals
Light Series (L)	12	25	25	25	25	25	20	30	45	35
	14	40	40	45	35	35	35	45	55	50
	16	55	55	55	55	40	45	65	80	60
	18	70	70	70	65	45	55	80	100	80
	22	90	90	125	90	60	65	140	140	120
	27	180	180	180	135	100	90	190	320	130
	33	310	310	310	225	160	150	340	360	
	42	450	450	450	360	210	240	500	540	
Heavy Series (S)	12	35	35	35		35	20	35	45	35
	14	55	55	45		45	35	55	55	50
	16	70	70	70		55	45	70	80	60
	18	90	90	90		70	55	110	100	80
	20	125	125	125	80	80	55	150	125	110
	22	135	135	135		100	65	170	135	120
	27	180	180	180		170	90	270	320	135
	33	310	310	310		310	150	410	360	
	42	450	450	450		330	240	540	540	
	48	540	540	540		420	290	700	700	

Please note:

- All torque values are intended for steel fittings.
- For Brass fittings and adapters use 65 % of the torque values.
- For Stainless steel fittings and adapters, use 5% higher value than listed and lubricate threads.

Installation of Tapered Port Fittings

When installing tapered fittings, the proper method is to utilize the 'turns from finger tight' method (T.F.F.T). Do not ever use torque settings for tapered fittings as many variables are involved especially when thread tape or sealant is used.

1. Observe unassembled parts, especially threads and bore to ensure it is free of foreign material, burrs, nicks, etc.
2. Apply thread sealant, tape or lubricant if not already applied. Do not cover the first 2 threads with any sealant or lubricant to avoid contaminating the system.
3. If a thread seal tape is used, make sure it is wrapped 1.5 to 2 turns in a clockwise direction when looking at the bore of the fitting.
4. Thread the tapered fitting into port until finger tight.
5. Using the suggested T.F.F.T values in the chart provided, wrench the fitting into place.
6. If the tapered fitting is an elbow, make sure the hose or tube end is oriented in the proper direction without having to loosen the fitting. Serious injury could occur if the fitting is loosened from its suggested T.F.F.T value.
7. Inspect the final assembly for leaks. The number of threads engaged should range from 3.5 and 6.

BSPT T.F.F.T Values

BSPT Dash Size	Inch Thread Size-TPI	Turns From Finger Tight (T.F.F.T)
02	1/8-28	2 – 3
04	1/4-19	2 – 3
06	3/8-19	2 – 3
08	1/2-14	2 – 3
10	5/8-14	2 – 3
12	3/4-14	2 – 3
16	1-11	1.5 – 2.5
20	1-1/4-11	1.5 – 2.5
24	1-1/2-11	1.5 – 2.5

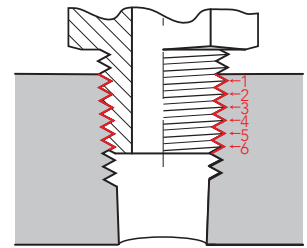

Inspect final assembly to ensure 3.5 to 6 threads are engaged

Installation of Female Swivel Fittings

1. Observe unassembled parts, especially threads and bore to ensure it is free of foreign material, burrs, nicks, etc.
2. Make sure the sealing surface angles are the same for the fittings you are connecting.
3. If there is an O-ring located on one of the cone seats, inspect it for damage and replace if used or worn. Make sure O-ring is seated properly and not cocked or twisted.
4. Never install an O-ring, bonded washer, or other seal at the base of the thread like you would a port fitting. Swivel fittings seal via internal surfaces.
5. Thread and then tighten the swivel nut with a torque wrench while holding the corresponding fitting body with a wrench. Torque to recommended settings.
6. If a crowsfoot is used with a torque wrench, adjustments might need to be made to the torque settings otherwise overtightening could occur. Consult your manufacturer for instructions.
7. Inspect final assembly for leaks.

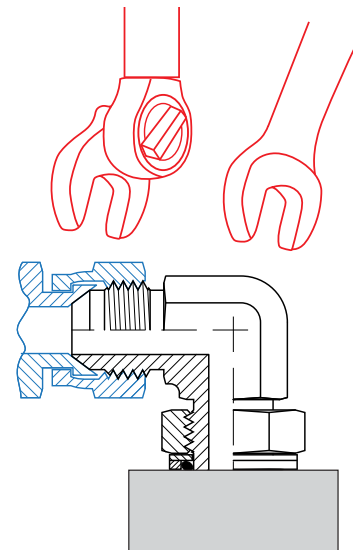

Hand tighten, then orient the fitting to face direction of hose or tube. Then torque the swivel nut to suggested setting while holding the fitting body. Inspect for leaks.

TUTORIALS HOW TO INSTALL FITTINGS & ADAPTERS

DIN DKO Swivel - Torque Settings

	Thread Size mm	Tube Size	DIN DKO Swivel (Nm)
L Light Duty	12	L06	16
	14	L08	16
	16	L10	26
	18	L12	37
	22	L15	47
	26	L18	89
	30	L22	116
	36	L28	137
	45	L35	226
	52	L42	347
S Heavy Duty	14	S06	26
	16	S08	42
	18	S10	53
	20	S12	63
	22	S14	79
	24	S16	84
	30	S20	126
	36	S25	179
	42	S30	263
52	S38	368	

BSPP Swivel - Torque Settings

Dash Thread Size	Inch Thread Size-Tpi	BSPP Swivel (Nm)
04	1/4-19	20
06	3/8-19	35
08	1/2-14	60
10	5/8-14	70
12	3/4-14	115
16	1-11	140
20	1-1/4-11	210
24	1-1/2-11	290

Please note:

- All torque values are intended for steel fittings.
- For Brass fittings and adapters use 65 % of the torque values.
- For Stainless steel fittings and adapters, use 5% higher value than listed and lubricate threads.

Installation of 24° DIN Tube Fittings

Make sure you fully read and understand the previous sections on DIN tube fittings and verify you have the correct components for your assembly.

1. The first step is to cut the tube to length, then de-burr and clean. Cut tubing with appropriate saw only.
2. Next, pre-set the cutting ring by initiating the bite into the tube. There are two ways to complete the pre-set: either a) manually with a fitting or hardened pre-assembly fitting body, or b) with a hydraulic pre-set machine. Hydraulic pre-setting is recommended for assemblies with tube size greater than 18mm.
3. Perform pre-set inspection to verify proper installation of cutting ring.
4. Install the assembly.

Manual Pre-set Method for 24° DIN Tube Fittings

1. Lubricate threads of fitting and nut, 24° throat, and cutting ring.
2. Place nut then cutting ring over tube, ensuring proper orientation.
3. Thread nut onto fitting until finger tight. Press tube firmly into the tube receptacle of the fitting while doing so.
4. Mark nut and tube position for reference with soap stone or marking pencil.
5. Tighten nut so that it completes 1.5 turns (use markings as reference), while at the same time ensuring the tube is stationary and pressed firmly into the tube receptacle. Sudden resistance to torquing is a sign the cutting ring is in a desired position. Be sure to secure fitting with wrench while tightening the nut.

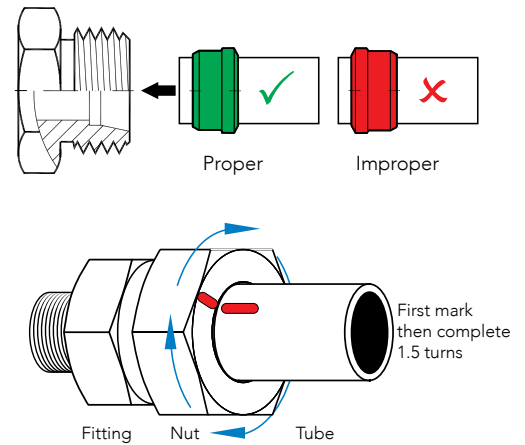

Hydraulic Pre-set Method for 24° DIN Tube Fittings

There are various hydraulic pre-set machines available with specific instructions for each. Please refer to your user's manual for operating instructions.

Pre-set Inspection

1. Remove the nut from fitting and pull back in order to inspect the cutting ring.
2. The cutting ring should leave no visible gap between the first cutting surface and the tube, and the tube should have a visible bite edge in front of the cutting ring (looks like slightly raised material).
3. If not, tighten in small increments (checking the result after each increment) to verify cutting ring is properly gripping the tube.

It is possible for the ring to rotate around the tube, however this does not indicate an improper installation as long as all other factors are correct.

Final Installation

Take the pre-set assembly and insert tube into the fitting's tube receptacle firmly, then tighten nut with light wrenching until resistance felt. Once this has been achieved, tighten the nut another 30° or 1/12th of a turn. This is the equivalent of turning the nut from a state where the hex is flat relative to a fixed point (i.e. a table) to where the sharp edge of the hex is now facing that position. Be sure to use a second wrench to hold the fitting in place while torquing the nut

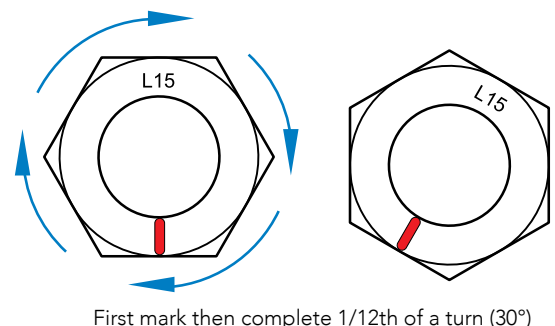
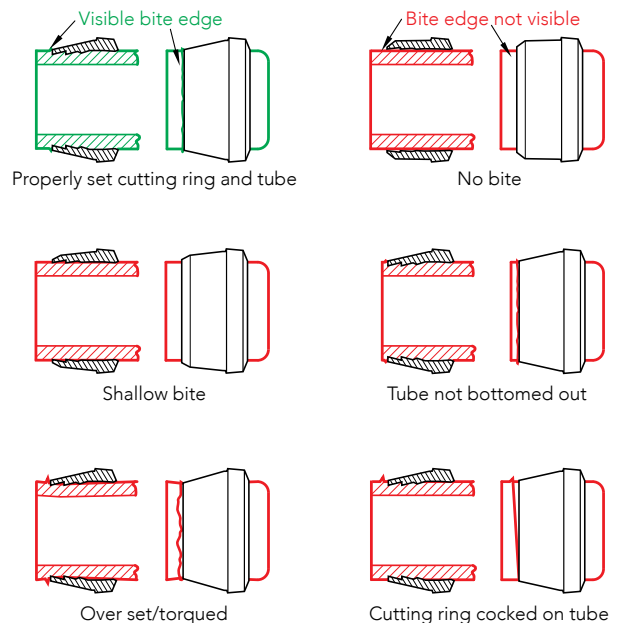

TUTORIALS HOW TO ORDER DIN FITTINGS FROM ADAPTALL

How to order 24° DIN Tube Fittings from Adaptall

To order 24° DIN tube fittings from Adaptall it is important to understand the part numbering system. This system is typical of most manufacturers:

1. The first four numbers indicate the part series i.e. 5000 is a male DIN union.
2. The pressure class (LL, L, or S) is indicated at the end of the series number i.e. 5000L, 5002S, 5063LL, etc.
3. For instances where a DIN x DIN fitting does not have a jump size, only one dash size is displayed. For example, a 5000L-06 is a light duty L06 x L06 DIN union.
4. The dash numbers indicate tube size when describing the DIN side of the fitting. From the last example, a 5000L-06 is an L06 indicating a M12x1.5 thread with 6mm tube receptacle; see 'Component Compatibility Chart' on page 14 for details on tube size & thread size relationship.
5. For non-DIN threads such as NPT, BSPP, etc., the regular dash system is used i.e. -08 indicates 1/2", -12 is 3/4", etc. Adaptall usually displays dash sizes with tube or hose side first, then port side.
6. To order a complete DIN assembly (including fitting, cutting ring, and nut) simply add a "C" to the end of the part number. For example, a complete L06 male DIN union assembly would be 5000L-06C, etc. Please note that all LL series (extra light duty) parts come complete.

When a complete assembly is ordered from Adaptall, there is no need to identify components to go along with your assembly. Adaptall will complete the necessary steps to ensure you are provided with compatible components.

Example:

Shown here in black only is 5158L-22-22-12: Male DIN X Male BSPP adjustable Run Tee, size L22 for the DIN threads, and dash size 12 BSPP (3/4"). When ordered as part number 5158L-22-22-12C it comes as a complete assembly with cutting rings and nuts for the two L22 Male DIN threads (components shown in green). Looking at the 'Component Compatibility Chart' on page 14, one would notice the compatible nuts for this assembly would be 5201L-22 with the compatible cutting rings being 5202-22.

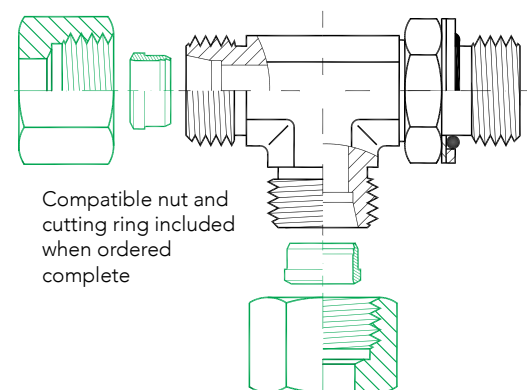

ASK ABOUT OUR CUSTOM BRANDING

TGK-01

BSP & METRIC THREAD ID GAUGE KIT

- BSPP, BSPT & JIS GAUGE (x1)
- METRIC, DIN, KOBELCO GAUGE (x1)

TGK-02

JIC, ORB (SAE), NPT AND ORFS THREAD ID GAUGE KIT

- JIC & ORB GAUGE (x1)
- NPT GAUGE (x1)
- ORFS GAUGE (x1)
- ANGLE GAUGE/RULER (x1)

FEATURED THREAD GAUGES

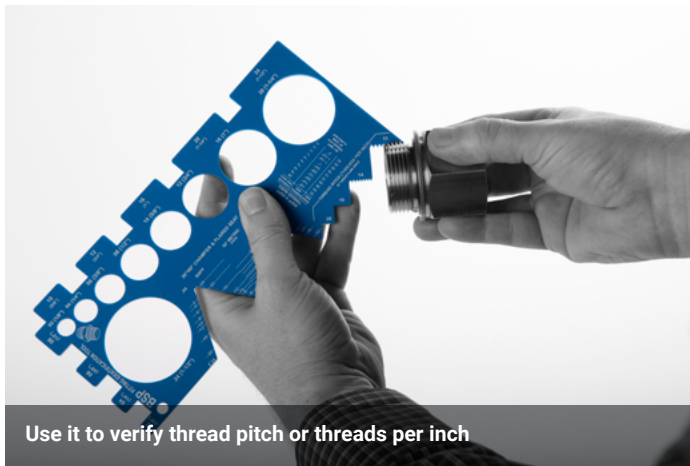
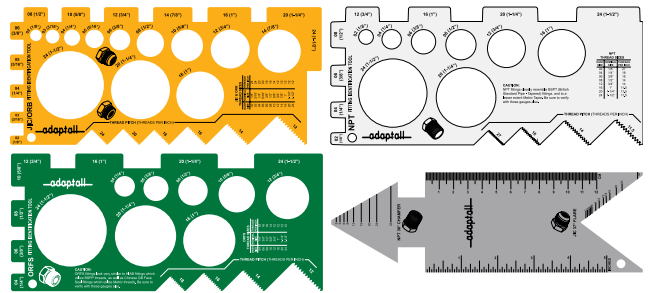
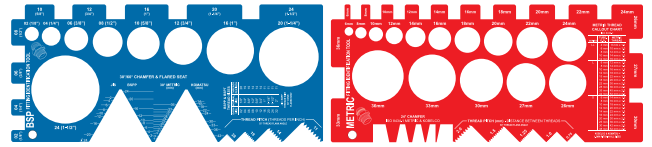

Use it to verify thread pitch or threads per inch



Chamfer and nose cone angles can be verified



Ports are used to identify male threads, posts for female threads



Useful in the field or shop



Convenient pouch holds multiple tools

FEATURED KITS

KIT-BANJO-BSPP

BSPP BANJO KIT (MALE JIC BANJO BODY X MALE BSPP BOLT)

3002-02 (x4)	3002-12 (x2)	3059-06-06 (x4)	3500-04 (x16)
3002-04 (x8)	3059-04-02 (x4)	3059-08-08 (x2)	3500-06 (x8)
3002-06 (x4)	3059-04-04 (x4)	3059-12-12 (x2)	3500-08 (x4)
3002-08 (x2)	3059-06-04 (x4)	3500-02 (x8)	3500-12 (x4)



KIT-BANJO-METRIC

METRIC BANJO KIT (MALE JIC BANJO BODY X MALE METRIC BOLT)

3068-08-1 (x4)	3068-20-150 (x2)	3069-08-18 (x4)	3500-16mm (x8)
3068-10-1 (x4)	3068-22-150 (x2)	3069-08-20 (x2)	3500-18mm (x8)
3068-10-150 (x4)	3069-04-08 (x4)	3069-10-22 (x2)	3500-20mm (x4)
3068-12-150 (x4)	3069-04-10 (x8)	3500-08mm (x8)	3500-22mm (x4)
3068-14-150 (x4)	3069-04-12 (x4)	3500-10mm (x16)	
3068-16-150 (x4)	3069-06-14 (x4)	3500-12mm (x4)	
3068-18-150 (x4)	3069-06-16 (x4)	3500-14mm (x8)	



KIT-BANJO-BSPP+MET

BSPP AND METRIC BANJO KIT COMBO

- BSPP BANJO KIT (x1)
- METRIC BANJO KIT (x1)



KIT-PL&CP-BSPP

BSPP PLUG AND CAP KIT

02 (4 PLUGS, 4 CAPS)	10 (2 PLUGS, 2 CAPS)
04 (4 PLUGS, 4 CAPS)	12 (4 PLUGS, 4 CAPS)
06 (4 PLUGS, 4 CAPS)	16 (2 PLUGS, 2 CAPS)
08 (4 PLUGS, 4 CAPS)	



KIT-PL&CP-DIN-L

DIN PLUG & CAP KIT - LIGHT DUTY

L06 (4 PLUGS, 4 CAPS)	L15 (6 PLUGS, 6 CAPS)
L08 (4 PLUGS, 4 CAPS)	L18 (4 PLUGS, 4 CAPS)
L10 (6 PLUGS, 6 CAPS)	L22 (4 PLUGS, 4 CAPS)
L12 (6 PLUGS, 6 CAPS)	L28 (2 PLUGS, 2 CAPS)



TUTORIALS
FEATURED
STEEL
STAINLESS STEEL
BRASS
MEALLEABLE IRON
QUICK REFERENCE
ABOUT

ASK ABOUT OUR CUSTOM BRANDING

KIT-PL&CP-DIN-S

DIN PLUG & CAP KIT - HEAVY DUTY

S06 (4 PLUGS, 4 CAPS)	S14 (4 PLUGS, 4 CAPS)
S08 (4 PLUGS, 4 CAPS)	S16 (4 PLUGS, 4 CAPS)
S10 (6 PLUGS, 6 CAPS)	S20 (2 PLUGS, 2 CAPS)
S12 (6 PLUGS, 6 CAPS)	S25 (2 PLUGS, 2 CAPS)

KIT-PL&CP-JIC

JIC PLUG AND CAP KIT

04 (10 PLUGS, 10 CAPS)	08 (4 PLUGS, 4 CAPS)	12 (2 PLUGS, 2 CAPS)
06 (10 PLUGS, 10 CAPS)	10 (3 PLUGS, 3 CAPS)	16 (2 PLUGS, 2 CAPS)

KIT-PL&CP-JIS

JIS PLUG & CAP KIT

04 (2 PLUGS, 2 CAPS)	08 (2 PLUGS, 2 CAPS)	16 (2 PLUGS, 2 CAPS)
06 (2 PLUGS, 2 CAPS)	12 (2 PLUGS, 2 CAPS)	20 (2 PLUGS, 2 CAPS)

KIT-PL&CP-KOMATSU

KOMATSU PLUG AND CAP KIT

14mm (2 PLUGS, 2 CAPS)	22mm (2 PLUGS, 2 CAPS)	30mm (2 PLUGS, 2 CAPS)
18mm (2 PLUGS, 2 CAPS)	24mm (2 PLUGS, 2 CAPS)	33mm (2 PLUGS, 2 CAPS)

KIT-PL&CP-NPT

NPT PLUG AND CAP KIT

02 (10 PLUGS, 10 CAPS)	06 (4 PLUGS, 4 CAPS)	12 (2 PLUGS, 2 CAPS)
04 (8 PLUGS, 8 CAPS)	08 (3 PLUGS, 3 CAPS)	16 (2 PLUGS, 2 CAPS)

FEATURED KITS



TUTORIALS

FEATURED

STEEL

STAINLESS STEEL

BRASS

MEALLEABLE IRON

QUICK REFERENCE

ABOUT

FEATURED KITS

KIT-PL&CP-ORFS

ORFS PLUG AND CAP KIT

04 (10 PLUGS, 10 CAPS)	08 (4 PLUGS, 4 CAPS)	12 (2 PLUGS, 2 CAPS)
06 (10 PLUGS, 10 CAPS)	10 (3 PLUGS, 3 CAPS)	16 (2 PLUGS, 2 CAPS)



KIT-9005ES

MJIC X MBSPP ES SEALED DUAL PURPOSE KIT

9005ES-04-02 (x4)	9005ES-06-06 (x4)	9005ES-12-12 (x4)
9005ES-04-04 (x4)	9005ES-08-06 (x4)	9005ES-16-16 (x2)
9005ES-04-06 (x4)	9005ES-08-08 (x4)	
9005ES-06-04 (x4)	9005ES-10-08 (x4)	



KIT-9197-LIGHT

MJIC X FDIN/DKO KIT - LIGHT DUTY

9197-04-L06-12 (x4)	9197-08-L12-18 (x2)	9197-16-L22-30 (x2)
9197-04-L08-14 (x4)	9197-10-L15-22 (x2)	9197-16-L28-36 (x2)
9197-06-L08-14 (x4)	9197-12-L18-26 (x2)	
9197-06-L10-16 (x4)	9197-12-L22-30 (x2)	



KIT-9197-HEAVY

MJIC X FDIN/DKO KIT - HEAVY DUTY

9197-04-S06-14 (x4)	9197-08-S16-24 (x2)
9197-06-S08-16 (x4)	9197-10-S16-24 (x2)
9197-06-S10-18 (x4)	9197-12-S20-30 (x2)
9197-08-S12-20 (x2)	9197-16-S25-36 (x2)



TUTORIALS
FEATURED
STEEL
STAINLESS STEEL
BRASS
MEALLEABLE IRON
QUICK REFERENCE
ABOUT

ASK ABOUT OUR CUSTOM BRANDING

KIT-SEALS-BSPP+MET

BONDED SEAL KIT BSPP & METRIC

BSPP 02 (x20)	BSPP 16 (x15)	16mm (x20)	27mm (x15)
BSPP 04 (x20)	BSPP 20 (x10)	18mm (x15)	30mm (x20)
BSPP 06 (x20)	8mm (x20)	20mm (x15)	33mm (x10)
BSPP 08 (x20)	10mm (x20)	22mm (x15)	36mm (x10)
BSPP 10 (x15)	12mm (x20)	24mm (x15)	
BSPP 12 (x15)	14mm (x20)	26mm (x20)	

KIT-SEATS-GB37/74

GB 37/74 CONVERSION SEATS FOR MALE DIN & FEMALE KOMATSU

5333-12MM (x4)	5333-30MM (x2)	9333-24MM (x2)
5333-14MM (x4)	9333-12MM (x4)	9333-30MM (x2)
5333-16MM (x4)	9333-14MM (x4)	
5333-18MM (x4)	9333-16MM (x4)	
5333-22MM (x4)	9333-18MM (x4)	
5333-24MM (x2)	9333-22MM (x4)	

KIT-SEATS-GB-FFACE

GB FACE SEAL CONVERSION SEATS FOR MALE DIN & FEMALE KOMATSU

5333FF-12MM (x4)	5333FF-30MM (x2)	9333FF-24MM (x2)
5333FF-14MM (x4)	9333FF-12MM (x4)	9333FF-30MM (x2)
5333FF-16MM (x4)	9333FF-14MM (x4)	
5333FF-18MM (x4)	9333FF-16MM (x4)	
5333FF-22MM (x4)	9333FF-18MM (x4)	
5333FF-24MM (x2)	9333FF-22MM (x4)	

KIT-SEATS-JIS&HIAB

JIS (9999) & HIAB (9777) CONVERSION SEATS FOR 30 DEG MBSPP

9999-02 (x4)	9999-16 (x2)	9777-10 (x2)
9999-04 (x4)	9999-20 (x2)	9777-12 (x4)
9999-06 (x4)	9999-24 (x2)	9777-16 (x2)
9999-08 (x4)	9777-04 (x4)	
9999-10 (x2)	9777-06 (x4)	
9999-12 (x4)	9777-08 (x4)	

FEATURED KITS

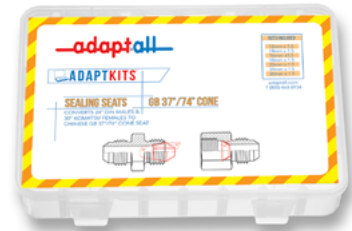
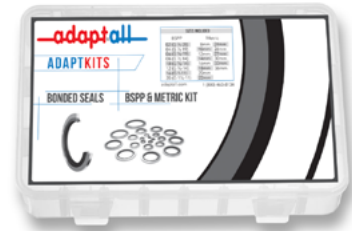

COMING 2020!



COMING 2020!



COMING 2020!

TUTORIALS

FEATURED

STEEL

STAINLESS STEEL

BRASS

MEALLEABLE IRON

QUICK REFERENCE

ABOUT

FEATURED STOCKING PROGRAMS

ASK ABOUT OUR CUSTOM BRANDING

TUTORIALS

FEATURED

STEEL

STAINLESS STEEL

BRASS

MEALLEABLE IRON QUICK REFERENCE

ABOUT

IA SSDO

INTERNATIONAL ADAPTERS ROLLING BIN RACK
240 FULLY STOCKED BINS OF POPULAR SIZES

INCLUDING:

6002 SERIES	9030 SERIES	9605S SERIES
6068 SERIES	9033 SERIES	9606S SERIES
9000 SERIES	9035S SERIES	9635S SERIES
9005ES SERIES	9059 SERIES	9636S SERIES
9006 SERIES	9069 SERIES	TGK GAUGES
9007 SERIES	9197 SERIES	BONDED SEAL KIT
9011 SERIES	9199 SERIES	
9021 SERIES	9240 SERIES	
9028 SERIES	9500 SERIES	
9029 SERIES	9500MM SERIES	



DIN SSDO

DIN TUBE FITTINGS & ADAPTERS ROLLING BIN RACK
240 FULLY STOCKED BINS OF POPULAR SIZES

INCLUDING:

5002 SERIES	5070 SERIES	5300 SERIES
5007 SERIES	5080 SERIES	5360 SERIES
5011 SERIES	5201 SERIES	TGK GAUGES
5055 SERIES	5202 SERIES	
5063 SERIES	5203 SERIES	
5068 SERIES	5204P SERIES	



STEEL BANJO ADAPTERS

3002

MALE BSPP BANJO BOLT

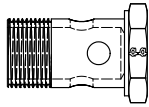

3002-02	3002-06	3002-12
3002-02-21L	3002-08	3002-16
3002-04	3002-08-41L	
3002-04-29L	3002-10	

3002DB

BSPP DOUBLE BANJO BOLT

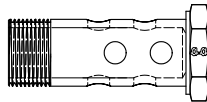

3002DB-02	3002DB-06	3002DB-12
3002DB-04	3002DB-08	3002DB-16

3048

MALE UNF BANJO BOLT

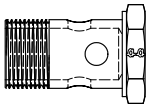

3048-04	3048-12
3048-06	3048-16
3048-08	
3048-10	

COMING 2020!

3049

MALE JIC X UNF BANJO BODY

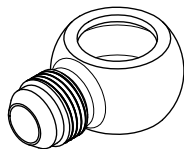

3049-04-04	3049-08-08
3049-05-04	3049-10-08
3049-06-04	3049-10-10
3049-06-06	3049-10-12
3049-06-08	3049-12-12
3049-08-06	3049-16-16

COMING 2020!

3049W

INCH TUBE WELD X UNF BANJO BODY

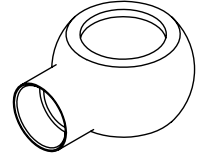

3049W-04-04	3049W-10-10
3049W-04-06	3049W-10-12
3049W-06-04	3049W-12-08
3049W-06-06	3049W-12-10
3049W-06-08	3049W-12-12
3049W-08-06	3049W-12-16
3049W-08-08	3049W-16-12
3049W-08-10	3049W-16-16
3049W-08-12	
3049W-10-08	

COMING 2020!

3059

MALE JIC X BSP BANJO BODY

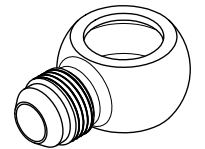

3059-04-02	3059-06-06	3059-12-12
3059-04-04	3059-08-08	3059-12-16
3059-05-04	3059-10-08	
3059-06-04	3059-10-12	

3059HB

HOSE BARB X BSP BANJO BODY (LOW PSI)

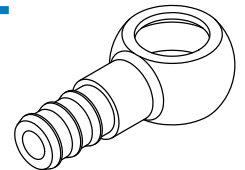

3059HB-04-02	3059HB-05-06	3059HB-08-08
3059HB-04-04	3059HB-06-06	

3068

METRIC BANJO BOLT

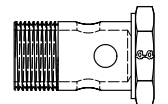

3068-08-1	3068-12-125	3068-18-150-40L
3068-08-125	3068-12-150	3068-20-150
3068-10-1	3068-14-150	3068-22-150
3068-10-125	3068-14-150-27L	3068-24-150
3068-10-150	3068-16-150	3068-26-150
3068-12-1	3068-18-150	

STEEL BANJO ADAPTERS

TUTORIALS

FEATURED

STEEL

STAINLESS STEEL

BRASS

MEALLEABLE IRON

QUICK REFERENCE

ABOUT

3068DB

METRIC DOUBLE BANJO BOLT

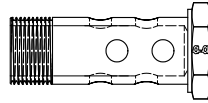

- | | |
|---------------|---------------|
| 3068DB-8-1 | 3068DB-14-150 |
| 3068DB-10-1 | 3068DB-16-150 |
| 3068DB-12-125 | 3068DB-18-150 |
| 3068DB-12-150 | 3068DB-22-150 |

3069

MALE JIC X METRIC BANJO BODY

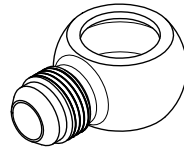

- | | | |
|------------|------------|------------|
| 3069-04-08 | 3069-06-16 | 3069-10-24 |
| 3069-04-10 | 3069-08-18 | 3069-12-26 |
| 3069-04-12 | 3069-08-20 | |
| 3069-06-14 | 3069-10-22 | |

3069HB

HOSE BARB X METRIC BANJO BODY (LOW PSI)

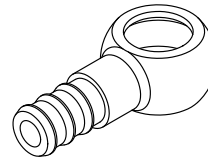

- | | | |
|--------------|--------------|--------------|
| 3069HB-04-08 | 3069HB-06-10 | 3069HB-08-16 |
| 3069HB-04-10 | 3069HB-06-12 | 3069HB-12-18 |
| 3069HB-05-12 | 3069HB-06-14 | |
| 3069HB-05-14 | 3069HB-08-14 | |

3069LL

MALE DIN EXTRA LIGHT DUTY X METRIC BANJO BODY

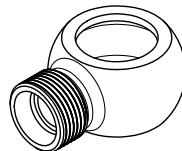

- | |
|--------------|
| 3069LL-10-10 |
|--------------|

3069L

MALE DIN LIGHT DUTY X METRIC BANJO BODY

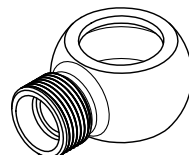

- | | | |
|-------------|-------------|-------------|
| 3069L-12-12 | 3069L-16-16 | 3069L-22-22 |
| 3069L-14-14 | 3069L-18-18 | 3069L-26-26 |

3069S

MALE DIN HEAVY DUTY X METRIC BANJO BODY

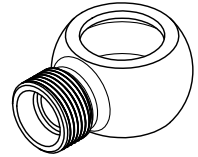

- | |
|-------------|
| 3069S-20-20 |
| 3069S-24-24 |

3069W

METRIC TUBE WELD X METRIC BANJO BODY

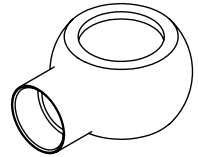

COMING 2020!

- | | | |
|-------------|-------------|-------------|
| 3069W-04-06 | 3069W-08-18 | 3069W-14-20 |
| 3069W-04-08 | 3069W-10-12 | 3069W-14-22 |
| 3069W-04-10 | 3069W-10-14 | 3069W-15-20 |
| 3069W-05-08 | 3069W-10-16 | 3069W-16-18 |
| 3069W-05-10 | 3069W-10-18 | 3069W-16-20 |
| 3069W-05-12 | 3069W-10-20 | 3069W-16-22 |
| 3069W-06-08 | 3069W-10-22 | 3069W-16-24 |
| 3069W-06-10 | 3069W-12-14 | 3069W-18-18 |
| 3069W-06-12 | 3069W-12-16 | 3069W-18-22 |
| 3069W-06-14 | 3069W-12-18 | 3069W-18-24 |
| 3069W-08-10 | 3069W-12-20 | 3069W-20-22 |
| 3069W-08-12 | 3069W-14-16 | 3069W-20-26 |
| 3069W-08-14 | 3069W-14-18 | 3069W-22-26 |
| 3069W-08-16 | 3069W-14-20 | |

3500

BSPP COPPER SEALING WASHERS

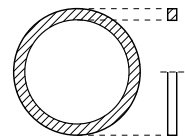

- | | |
|---------|---------|
| 3500-02 | 3500-10 |
| 3500-04 | 3500-12 |
| 3500-06 | 3500-16 |
| 3500-08 | |

3500MM

METRIC COPPER SEALING WASHERS

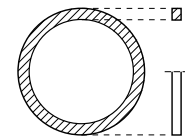

- | | | |
|-----------|-----------|-----------|
| 3500-08MM | 3500-16MM | 3500-24MM |
| 3500-10MM | 3500-18MM | 3500-26MM |
| 3500-12MM | 3500-20MM | |
| 3500-14MM | 3500-22MM | |

STEEL 24° DIN TUBE FITTINGS/ADAPTERS

5000LL

DIN UNION EXTRA LIGHT DUTY
(AVAILABLE COMPLETE ONLY)

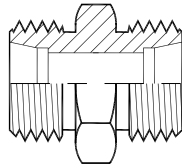

5000LL-04C
5000LL-06C

5000LL-08C
5000LL-10C

5000LL-12C

5000L

DIN UNION LIGHT DUTY

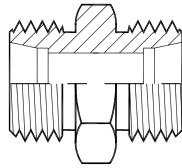

5000L-06

5000L-12-08

5000L-18-15

5000L-08

5000L-12-10

5000L-22

5000L-08-06

5000L-15

5000L-22-15

5000L-10

5000L-15-10

5000L-22-18

5000L-10-06

5000L-15-12

5000L-28

5000L-10-08

5000L-18

5000L-28-22

5000L-12

5000L-18-10

5000L-35

5000L-12-06

5000L-18-12

5000L-42

5000S

DIN UNION HEAVY DUTY

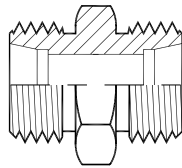

5000S-06

5000S-14

5000S-25-16

5000S-08

5000S-16

5000S-25-20

5000S-10

5000S-16-12

5000S-30

5000S-10-08

5000S-20

5000S-38

5000S-12

5000S-20-16

5000S-12-10

5000S-25

5002L

DIN LIGHT DUTY X MALE
BSPP ES SEAL

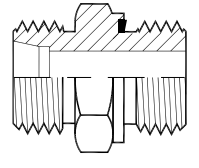

5002L-06-02

5002L-12-06

5002L-28-12

5002L-06-04

5002L-12-08

5002L-28-16

5002L-08-02

5002L-15-06

5002L-35-16

5002L-08-04

5002L-15-08

5002L-35-20

5002L-08-06

5002L-15-12

5002L-42-20

5002L-10-02

5002L-18-08

5002L-42-24

5002L-10-04

5002L-18-12

5002L-10-06

5002L-22-08

5002L-10-08

5002L-22-12

5002L-12-04

5002L-22-16

5002S

DIN HEAVY DUTY X MALE
BSPP ES SEAL

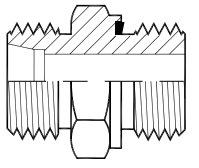

5002S-06-04

5002S-12-08

5002S-20-16

5002S-08-04

5002S-14-06

5002S-25-12

5002S-08-06

5002S-14-08

5002S-25-16

5002S-10-04

5002S-16-06

5002S-30-16

5002S-10-06

5002S-16-08

5002S-30-20

5002S-10-08

5002S-16-12

5002S-38-20

5002S-12-04

5002S-20-08

5002S-38-24

5002S-12-06

5002S-20-12

5006L

DIN LIGHT DUTY X MALE SAE
ORB

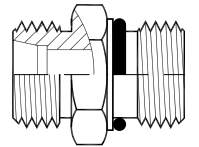

5006L-06-04

5006L-12-08

5006L-22-16

5006L-06-06

5006L-12-10

5006L-28-10

5006L-08-04

5006L-15-08

5006L-28-12

5006L-08-06

5006L-15-10

5006L-28-16

5006L-10-04

5006L-18-08

5006L-35-16

5006L-10-06

5006L-18-10

5006L-35-20

5006L-10-08

5006L-22-10

5006L-42-20

5006L-12-06

5006L-22-12

5006L-42-24

To order with nut(s) and cutting ring(s) add a "C" to the end of the part number.

STEEL 24° DIN TUBE FITTINGS/ADAPTERS

TUTORIALS

FEATURED

STEEL

STAINLESS STEEL

BRASS

MEALLEABLE IRON

QUICK REFERENCE

ABOUT

5006S

DIN HEAVY DUTY X MALE SAE ORB

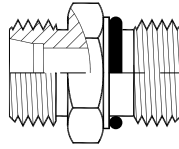

5006S-08-04	5006S-16-10	5006S-30-16
5006S-10-06	5006S-20-08	5006S-30-20
5006S-12-06	5006S-20-10	5006S-38-20
5006S-12-08	5006S-20-12	5006S-38-24
5006S-14-08	5006S-25-12	
5006S-16-08	5006S-25-16	

5007LL

DIN EXTRA LIGHT X MALE NPT (AVAILABLE COMPLETE ONLY)

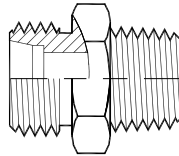

5007LL-04-02C	5007LL-08-02C	5007LL-12-06C
5007LL-06-02C	5007LL-10-04C	5007LL-12-08C

5007L

DIN LIGHT DUTY X MALE NPT

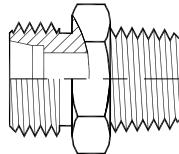

5007L-06-02	5007L-12-04	5007L-28-16
5007L-06-04	5007L-12-06	5007L-35-20
5007L-08-02	5007L-12-08	5007L-42-24
5007L-08-04	5007L-15-06	
5007L-08-06	5007L-15-08	
5007L-10-04	5007L-18-08	
5007L-10-06	5007L-18-12	
5007L-10-08	5007L-22-12	

5007S

DIN HEAVY DUTY X MALE NPT

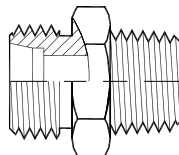

5007S-06-04	5007S-12-08	5007S-20-12
5007S-08-04	5007S-14-06	5007S-25-12
5007S-10-04	5007S-14-08	5007S-25-16
5007S-10-06	5007S-16-06	5007S-30-16
5007S-12-04	5007S-16-08	5007S-30-20
5007S-12-06	5007S-20-08	5007S-38-24

5009GCL

DIN LIGHT DUTY X FEMALE BSP GAUGE COUPLING (AVAILABLE COMPLETE ONLY)

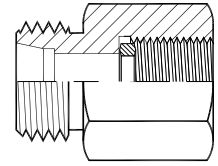

5009GCL-06-04C	5009GCL-10-04C
5009GCL-08-04C	5009GCL-12-04C

5009GCS

DIN HEAVY DUTY X FEMALE BSP GAUGE COUPLING (AVAILABLE COMPLETE ONLY)

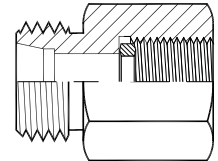

5009GCS-06-08C	5009GCS-10-08C
5009GCS-08-08C	5009GCS-12-08C

5009L

DIN LIGHT DUTY X FEMALE BSP SOLID

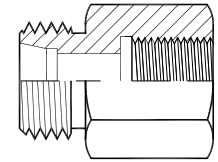

5009L-06-02	5009L-12-06	5009L-22-12
5009L-08-04	5009L-12-08	5009L-28-16
5009L-10-04	5009L-15-08	5009L-35-20
5009L-12-04	5009L-18-08	5009L-42-24

5009S

DIN HEAVY DUTY X FEMALE BSP SOLID

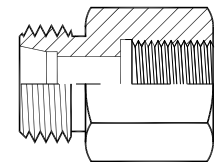

5009S-06-04	5009S-14-08	5009S-30-20
5009S-08-04	5009S-16-08	5009S-38-24
5009S-10-06	5009S-20-12	
5009S-12-06	5009S-25-16	

STEEL 24° DIN TUBE FITTINGS/ADAPTERS

5011LL

DIN EXTRA LIGHT DUTY X MALE BSPT (AVAILABLE COMPLETE ONLY)

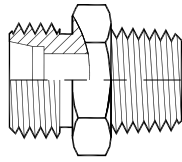

- | | | |
|---------------|---------------|---------------|
| 5011LL-04-02C | 5011LL-08-02C | 5011LL-10-04C |
| 5011LL-06-02C | 5011LL-08-04C | 5011LL-12-06C |

5011L

DIN LIGHT DUTY X MALE BSPT

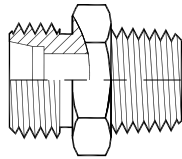

- | | | |
|-------------|-------------|-------------|
| 5011L-06-02 | 5011L-12-04 | 5011L-28-16 |
| 5011L-06-04 | 5011L-12-06 | 5011L-35-20 |
| 5011L-08-02 | 5011L-12-08 | 5011L-42-24 |
| 5011L-08-04 | 5011L-15-06 | |
| 5011L-08-06 | 5011L-15-08 | |
| 5011L-10-02 | 5011L-18-08 | |
| 5011L-10-04 | 5011L-18-12 | |
| 5011L-10-06 | 5011L-22-12 | |

5011S

DIN HEAVY DUTY X MALE BSPT

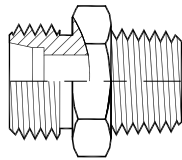

- | | | |
|-------------|-------------|-------------|
| 5011S-06-04 | 5011S-14-08 | 5011S-25-16 |
| 5011S-08-04 | 5011S-16-06 | 5011S-30-16 |
| 5011S-10-06 | 5011S-16-08 | 5011S-30-20 |
| 5011S-12-06 | 5011S-20-08 | 5011S-38-24 |
| 5011S-12-08 | 5011S-20-12 | |
| 5011S-14-06 | 5011S-25-12 | |

5040ES-L

DIN LIGHT DUTY BULKHEAD X MALE BSPP ES SEAL

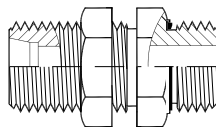

- | | | |
|----------------|----------------|----------------|
| 5040-L06-02ESX | 5040-L12-08ESX | 5040-L18-12ESX |
| 5040-L10-06ESX | 5040-L15-12ESX | |

5040ES-S

DIN HEAVY DUTY BULKHEAD X MALE BSPP ES SEAL

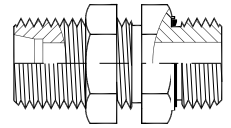

- | | |
|----------------|----------------|
| 5040-S10-04ESX | 5040-S16-08ESX |
| 5040-S12-06ESX | 5040-S16-12ESX |
| 5040-S12-08ESX | 5040-S20-08ESX |
| 5040-S14-08ESX | 5040-S25-16ESX |

5040L

DIN BULKHEAD UNION LIGHT DUTY

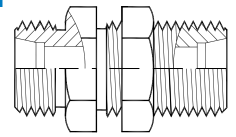

- | | | |
|----------|----------|----------|
| 5040L-06 | 5040L-15 | 5040L-35 |
| 5040L-08 | 5040L-18 | 5040L-42 |
| 5040L-10 | 5040L-22 | |
| 5040L-12 | 5040L-28 | |

5040S

DIN BULKHEAD UNION HEAVY DUTY

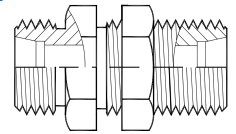

- | | | |
|----------|----------|----------|
| 5040S-06 | 5040S-14 | 5040S-30 |
| 5040S-08 | 5040S-16 | 5040S-38 |
| 5040S-10 | 5040S-20 | |
| 5040S-12 | 5040S-25 | |

5041

METRIC BULKHEAD NUT

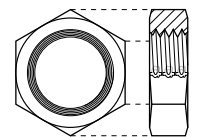

- | | | |
|---------|---------|---------|
| 5041-12 | 5041-24 | 5041-52 |
| 5041-14 | 5041-26 | |
| 5041-16 | 5041-30 | |
| 5041-18 | 5041-36 | |
| 5041-20 | 5041-42 | |
| 5041-22 | 5041-45 | |

To order with nut(s) and cutting ring(s) add a "C" to the end of the part number.

STEEL 24° DIN TUBE FITTINGS/ADAPTERS

TUTORIALS

FEATURED

STEEL

STAINLESS STEEL

BRASS

MEALLEABLE IRON QUICK REFERENCE

ABOUT

5042L

90° DIN LIGHT DUTY BULKHEAD UNION ELBOW

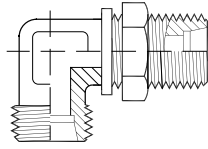

5042L-06	5042L-15	5042L-35
5042L-08	5042L-18	5042L-42
5042L-10	5042L-22	
5042L-12	5042L-28	

5055S

90° DIN UNION HEAVY DUTY ELBOW

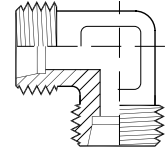

5055S-06	5055S-14	5055S-30
5055S-08	5055S-16	5055S-38
5055S-10	5055S-20	
5055S-12	5055S-25	

5042S

90° DIN HEAVY DUTY BULKHEAD UNION ELBOW

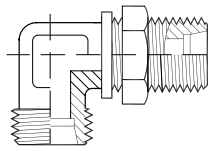

5042S-06	5042S-14	5042S-30
5042S-08	5042S-16	5042S-38
5042S-10	5042S-20	
5042S-12	5042S-25	

5058L

45° DIN LIGHT DUTY X MALE BSPP ADJUSTABLE ELBOW

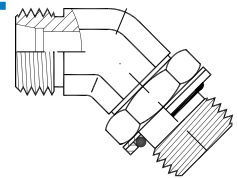

5058L-06-02	5058L-15-08
5058L-08-04	5058L-18-08
5058L-10-04	5058L-22-12
5058L-12-06	5058L-28-16

5055LL

90° DIN UNION EXTRA LIGHT DUTY ELBOW
(AVAILABLE COMPLETE ONLY)

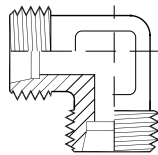

5055LL-04C	5055LL-08C	5055LL-12C
5055LL-06C	5055LL-10C	

5058S

45° DIN HEAVY DUTY X MALE BSPP ADJUSTABLE ELBOW

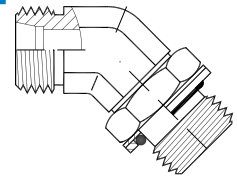

5058S-06-04	5058S-14-08
5058S-08-04	5058S-16-08
5058S-10-06	5058S-20-12
5058S-12-06	5058S-25-16

5055L

90° DIN UNION LIGHT DUTY ELBOW

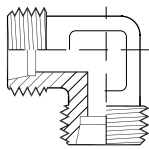

5055L-06	5055L-15	5055L-35
5055L-08	5055L-18	5055L-42
5055L-10	5055L-22	
5055L-12	5055L-28	

5059BJL

90° DIN LIGHT DUTY BANJO X MALE BSPP ES SEAL ELBOW

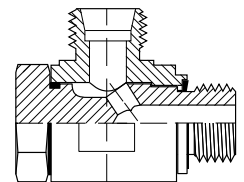

5059BJL-06-02	5059BJL-15-08	5059BJL-35-20
5059BJL-08-04	5059BJL-18-08	5059BJL-42-24
5059BJL-10-04	5059BJL-22-12	
5059BJL-12-06	5059BJL-28-16	

STEEL 24° DIN TUBE FITTINGS/ADAPTERS

5059BJS

90° DIN HEAVY DUTY BANJO X MALE BSPP ES SEAL ELBOW

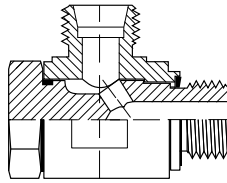

5059BJS-06-04	5059BJS-14-08	5059BJS-30-20
5059BJS-08-04	5059BJS-16-08	5059BJS-38-24
5059BJS-10-06	5059BJS-20-12	
5059BJS-12-06	5059BJS-25-16	

5059L

90° DIN LIGHT DUTY X MALE BSPP ADJUSTABLE ELBOW

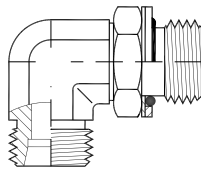

5059L-06-02	5059L-15-06	5059L-35-20
5059L-08-04	5059L-15-08	5059L-42-24
5059L-10-04	5059L-18-08	
5059L-10-06	5059L-18-12	
5059L-12-06	5059L-22-12	
5059L-12-08	5059L-28-16	

5059S

90° DIN HEAVY DUTY X MALE BSPP ADJUSTABLE ELBOW

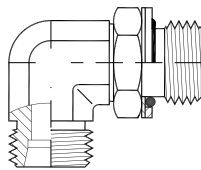

5059S-06-04	5059S-14-08	5059S-30-20
5059S-08-04	5059S-16-08	5059S-38-24
5059S-10-06	5059S-20-12	
5059S-12-06	5059S-25-16	

5063LL

90° DIN EXTRA LIGHT DUTY X MALE BSPT ELBOW
(AVAILABLE COMPLETE ONLY)

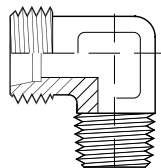

5063LL-04-02C	5063LL-08-02C	5063LL-12-06C
5063LL-06-02C	5063LL-10-04C	

5063L

90° DIN LIGHT DUTY X MALE BSPT ELBOW

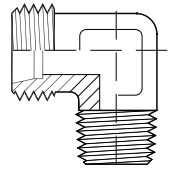

5063L-06-02	5063L-12-04	5063L-28-16
5063L-06-04	5063L-12-06	5063L-35-20
5063L-08-02	5063L-12-08	5063L-42-24
5063L-08-04	5063L-15-06	
5063L-10-02	5063L-15-08	
5063L-10-04	5063L-18-08	
5063L-10-06	5063L-18-12	
5063L-10-08	5063L-22-12	

5063S

90° DIN HEAVY DUTY X MALE BSPT ELBOW

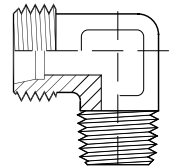

5063S-06-04	5063S-14-08	5063S-25-16
5063S-08-04	5063S-16-06	5063S-30-16
5063S-10-06	5063S-16-08	5063S-30-20
5063S-12-06	5063S-20-08	5063S-38-24
5063S-12-08	5063S-20-12	
5063S-14-06	5063S-25-12	

5066L

45° DIN LIGHT DUTY X MALE METRIC ADJUSTABLE ELBOW

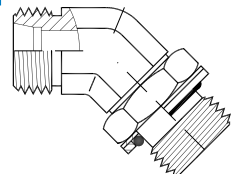

5066L-06-10	5066L-15-18
5066L-08-12	5066L-18-22
5066L-10-14	5066L-22-27
5066L-12-16	5066L-28-33

5066S

45° DIN HEAVY DUTY X MALE METRIC ADJUSTABLE ELBOW

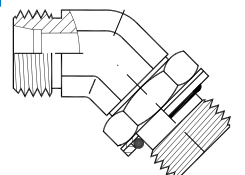

5066S-06-12	5066S-14-20
5066S-08-14	5066S-16-22
5066S-10-16	5066S-20-27
5066S-12-18	5066S-25-33

To order with nut(s) and cutting ring(s) add a "C" to the end of the part number.

STEEL 24° DIN TUBE FITTINGS/ADAPTERS

TUTORIALS

FEATURED

STEEL

STAINLESS STEEL

BRASS

MEALLEABLE IRON

QUICK REFERENCE

ABOUT

5068L

DIN LIGHT DUTY X MALE METRIC ES SEAL

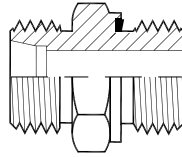

5068L-06-10	5068L-12-14	5068L-18-22
5068L-08-10	5068L-12-16	5068L-22-22
5068L-08-12	5068L-12-18	5068L-22-26
5068L-08-18	5068L-12-22	5068L-28-33
5068L-10-14	5068L-15-16	5068L-35-42
5068L-10-16	5068L-15-18	5068L-42-48
5068L-10-18	5068L-15-22	
5068L-10-22	5068L-18-18	

5068S

DIN HEAVY DUTY X MALE METRIC ES SEAL

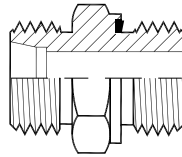

5068S-06-12	5068S-16-18	5068S-30-33
5068S-08-14	5068S-16-22	5068S-30-42
5068S-10-16	5068S-20-22	5068S-38-48
5068S-12-18	5068S-20-27	
5068S-12-22	5068S-25-27	
5068S-14-20	5068S-25-33	

5068LLT

DIN EXTRA LIGHT DUTY X MALE METRIC TAPER (AVAILABLE COMPLETE ONLY)

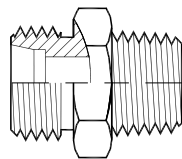

5068LLT-04-6X1C	5068LLT-06-10X1C
5068LLT-04-8X1C	5068LLT-08-10X1C

5069BJL

90° DIN LIGHT BANJO X MALE METRIC ES SEAL ELBOW

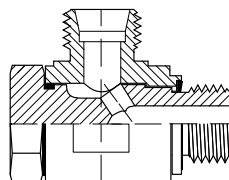

5069BJL-06-10	5069BJL-15-18	5069BJL-35-42
5069BJL-08-12	5069BJL-18-22	5069BJL-42-48
5069BJL-10-14	5069BJL-22-26	
5069BJL-12-16	5069BJL-28-33	

5069BJS

90° DIN HEAVY BANJO X MALE METRIC ES SEAL ELBOW

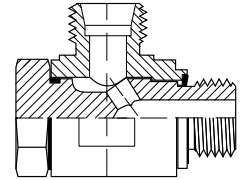

5069BJS-06-12	5069BJS-14-20	5069BJS-30-42
5069BJS-08-14	5069BJS-16-22	5069BJS-38-48
5069BJS-10-16	5069BJS-20-27	
5069BJS-12-18	5069BJS-25-33	

5069L

90° DIN LIGHT DUTY X MALE METRIC ADJUSTABLE ELBOW

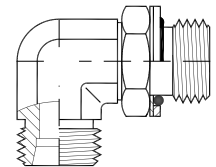

5069L-06-10	5069L-15-18	5069L-35-42
5069L-08-12	5069L-18-22	5069L-42-48
5069L-10-14	5069L-22-27	
5069L-12-16	5069L-28-33	

5069S

90° DIN HEAVY DUTY X MALE METRIC ADJUSTABLE ELBOW

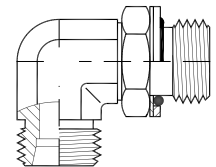

5069S-06-12	5069S-14-20	5069S-30-42
5069S-08-14	5069S-16-22	5069S-38-48
5069S-10-16	5069S-20-27	
5069S-12-18	5069S-25-33	

5069LLT

90° DIN EXTRA LIGHT DUTY X MALE METRIC TAPER ELBOW (AVAILABLE COMPLETE ONLY)

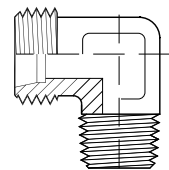

5069LLT-06-10X1C
5069LLT-08-10X1C

STEEL 24° DIN TUBE FITTINGS/ADAPTERS

5070LL

90° DIN EXTRA LIGHT DUTY X MALE NPT ELBOW
(AVAILABLE COMPLETE ONLY)

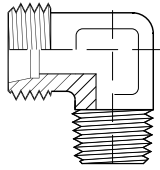

5070LL-04-02C	5070LL-08-02C	5070LL-12-06C
5070LL-06-02C	5070LL-10-04C	

5070L

90° DIN LIGHT DUTY X MALE NPT ELBOW

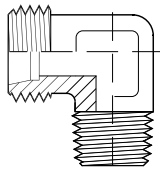

5070L-06-02	5070L-12-04	5070L-28-16
5070L-06-04	5070L-12-06	5070L-35-20
5070L-08-02	5070L-12-08	5070L-42-24
5070L-08-04	5070L-15-06	
5070L-10-02	5070L-15-08	
5070L-10-04	5070L-18-08	
5070L-10-06	5070L-18-12	
5070L-10-08	5070L-22-12	

5070S

90° DIN HEAVY DUTY X MALE NPT ELBOW

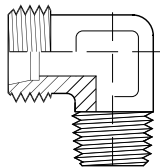

5070S-06-04	5070S-14-08	5070S-25-16
5070S-08-04	5070S-16-06	5070S-30-16
5070S-10-06	5070S-16-08	5070S-30-20
5070S-12-06	5070S-20-08	5070S-38-24
5070S-12-08	5070S-20-12	
5070S-14-06	5070S-25-12	

5077L

90° DIN LIGHT DUTY X MALE SAE ORB ADJUSTABLE ELBOW

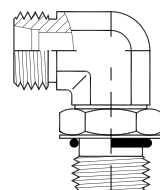

5077L-06-04	5077L-15-10	5077L-35-20
5077L-08-04	5077L-18-10	5077L-42-24
5077L-10-06	5077L-22-12	
5077L-12-08	5077L-28-16	

5077S

90° DIN HEAVY DUTY X MALE SAE ORB ADJUSTABLE ELBOW

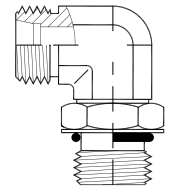

5077S-06-04	5077S-14-10	5077S-30-20
5077S-08-06	5077S-16-10	5077S-38-24
5077S-10-06	5077S-20-12	
5077S-12-08	5077S-25-16	

5080LL

DIN UNION TEE EXTRA LIGHT DUTY (AVAILABLE COMPLETE ONLY)

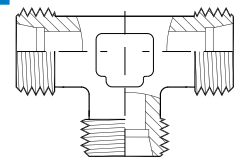

5080LL-04C	5080LL-08C	5080LL-12C
5080LL-06C	5080LL-10C	

5080L

DIN UNION TEE LIGHT DUTY

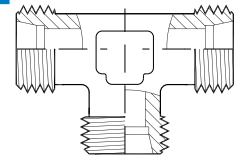

5080L-06	5080L-15	5080L-35
5080L-08	5080L-18	5080L-42
5080L-10	5080L-22	
5080L-12	5080L-28	

5080S

DIN UNION TEE HEAVY DUTY

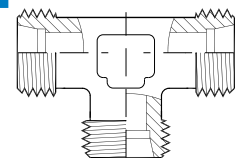

5080S-06	5080S-14	5080S-30
5080S-08	5080S-16	5080S-38
5080S-10	5080S-20	
5080S-12	5080S-25	

To order with nut(s) and cutting ring(s) add a "C" to the end of the part number.

STEEL 24° DIN TUBE FITTINGS/ADAPTERS

TUTORIALS

FEATURED

STEEL

STAINLESS STEEL

BRASS

MEALLEABLE IRON QUICK REFERENCE

ABOUT

5096L

DIN UNION CROSS LIGHT DUTY

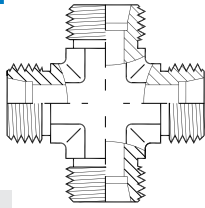

5096L-06
5096L-08

5096L-10
5096L-12

5096S

DIN UNION CROSS HEAVY DUTY

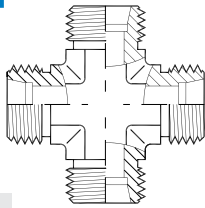

5096S-06
5096S-08

5096S-10
5096S-12

5158L

DIN LIGHT DUTY X MALE BSPP
ADJUSTABLE RUN TEE

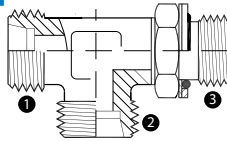

5158L-06-06-02
5158L-08-08-04
5158L-10-10-04
5158L-12-12-06

5158L-15-15-08
5158L-18-18-08
5158L-22-22-12
5158L-28-28-16

5158L-35-35-20
5158L-42-42-24

5158S

DIN HEAVY DUTY X MALE BSPP
ADJUSTABLE RUN TEE

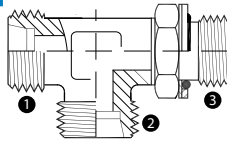

5158S-06-06-04
5158S-08-08-04
5158S-10-10-06
5158S-12-12-06

5158S-14-14-08
5158S-16-16-08
5158S-20-20-12
5158S-25-25-16

5158S-30-30-20
5158S-38-38-24

5159L

DIN LIGHT DUTY X MALE BSPP
ADJUSTABLE BRANCH TEE

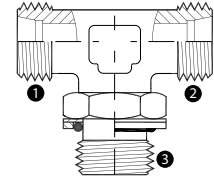

5159L-06-06-02
5159L-08-08-04
5159L-10-10-04
5159L-12-12-06

5159L-15-15-08
5159L-18-18-08
5159L-22-22-12
5159L-28-28-16

5159L-35-35-20
5159L-42-42-24

5159S

DIN HEAVY DUTY X MALE BSPP
ADJUSTABLE BRANCH TEE

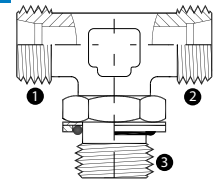

5159S-06-06-04
5159S-08-08-04
5159S-10-10-06
5159S-12-12-06

5159S-14-14-08
5159S-16-16-08
5159S-20-20-12
5159S-25-25-16

5159S-30-30-20
5159S-38-38-24

5168L

DIN LIGHT DUTY X MALE
METRIC ADJUSTABLE RUN TEE

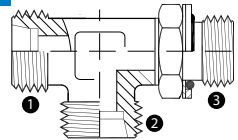

5168L-06-06-10
5168L-08-08-12
5168L-10-10-14
5168L-12-12-16

5168L-15-15-18
5168L-18-18-22
5168L-22-22-27
5168L-28-28-33

5168L-35-35-42
5168L-42-42-48

5168S

DIN HEAVY DUTY X MALE
METRIC ADJUSTABLE RUN TEE

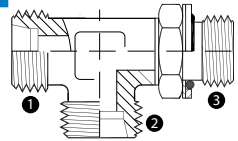

5168S-06-06-12
5168S-08-08-14
5168S-10-10-16
5168S-12-12-18

5168S-14-14-20
5168S-16-16-22
5168S-20-20-27
5168S-25-25-33

5168S-30-30-42
5168S-38-38-48

STEEL 24° DIN TUBE FITTINGS/ADAPTERS

5169L

DIN LIGHT DUTY X MALE METRIC
ADJUSTABLE BRANCH TEE

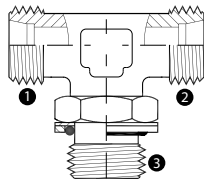

5169L-06-06-10	5169L-15-15-18	5169L-35-35-42
5169L-08-08-12	5169L-18-18-22	5169L-42-42-48
5169L-10-10-14	5169L-22-22-27	
5169L-12-12-16	5169L-28-28-33	

5169S

DIN HEAVY DUTY X MALE METRIC
ADJUSTABLE BRANCH TEE

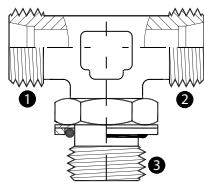

5169S-06-06-12	5169S-14-14-20	5169S-30-30-42
5169S-08-08-14	5169S-16-16-22	5169S-38-38-48
5169S-10-10-16	5169S-20-20-27	
5169S-12-12-18	5169S-25-25-33	

5178L

DIN LIGHT DUTY X MALE SAE
ORB ADJUSTABLE RUN TEE

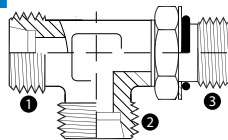

5178L-06-06-04	5178L-15-15-10	5178L-35-35-20
5178L-08-08-04	5178L-18-18-10	5178L-42-42-24
5178L-10-10-06	5178L-22-22-12	
5178L-12-12-08	5178L-28-28-16	

5178S

DIN HEAVY DUTY X MALE SAE
ORB ADJUSTABLE RUN TEE

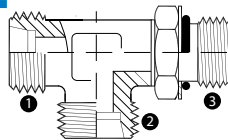

5178S-06-06-04	5178S-14-14-10	5178S-30-30-20
5178S-08-08-06	5178S-16-16-10	5178S-38-38-24
5178S-10-10-06	5178S-20-20-12	
5178S-12-12-08	5178S-25-25-16	

5179L

DIN LIGHT DUTY X MALE SAE
ORB ADJUSTABLE BRANCH TEE

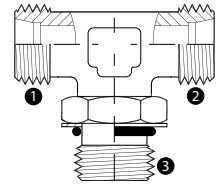

5179L-06-06-04	5179L-15-15-10	5179L-28-28-16
5179L-08-08-04	5179L-18-18-10	5179L-35-35-20
5179L-10-10-06	5179L-18-18-12	5179L-42-42-24
5179L-12-12-08	5179L-22-22-12	

5179S

DIN HEAVY DUTY X MALE SAE
ORB ADJUSTABLE BRANCH TEE

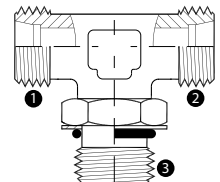

5179S-06-06-04	5179S-14-14-10	5179S-30-30-20
5179S-08-08-06	5179S-16-16-10	5179S-38-38-24
5179S-10-10-06	5179S-20-20-12	
5179S-12-12-08	5179S-25-25-16	

5201LL

DIN EXTRA LIGHT DUTY TUBE NUT

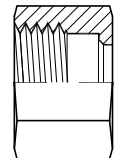

5201LL-04	5201LL-08	5201LL-12
5201LL-06	5201LL-10	

5201L

DIN LIGHT DUTY TUBE NUT

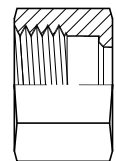

5201L-06	5201L-22	5201L-42
5201L-08	5201L-22-30X1.5	
5201L-10	5201L-28	
5201L-12	5201L-28-36X1.5	
5201L-15	5201L-35	
5201L-18	5201L-35-45X1.5	

To order with nut(s) and cutting ring(s) add a "C" to the end of the part number.

STEEL 24° DIN TUBE FITTINGS/ADAPTERS

TUTORIALS

FEATURED

STEEL

STAINLESS STEEL

BRASS

MEALLEABLE IRON

QUICK REFERENCE

ABOUT

5201S

DIN HEAVY DUTY TUBE NUT



5201S-06	5201S-14	5201S-30
5201S-08	5201S-16	5201S-38
5201S-10	5201S-20	
5201S-12	5201S-25	

5203S

DIN HEAVY DUTY TUBE PLUG

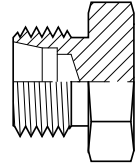

5203S-06	5203S-14	5203S-30
5203S-08	5203S-16	5203S-38
5203S-10	5203S-20	
5203S-12	5203S-25	

5202

DIN 2353 CUTTING RING

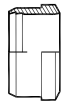

5202-06	5202-16	5202-30
5202-08	5202-18	5202-35
5202-10	5202-20	5202-38
5202-12	5202-22	5202-42
5202-14	5202-25	
5202-15	5202-28	

5204L

DIN LIGHT DUTY TUBE CAP

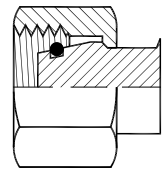

5204L-06	5204L-15	5204L-35
5204L-08	5204L-18	5204L-42
5204L-10	5204L-22	
5204L-12	5204L-28	

5204S

DIN HEAVY DUTY TUBE CAP

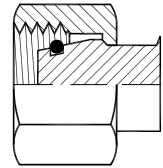

5204S-06	5204S-14	5204S-30
5204S-08	5204S-16	5204S-38
5204S-10	5204S-20	
5204S-12	5204S-25	

5202LL

DIN 2353 EXTRA LIGHT CUTTING RING

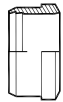

5202LL-04	5202LL-08	5202LL-12
5202LL-06	5202LL-10	

5203L

DIN LIGHT DUTY TUBE PLUG

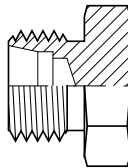

5203L-06	5203L-15	5203L-28
5203L-08	5203L-18	5203L-35
5203L-10	5203L-22	5203L-42
5203L-12	5203L-22-30X1.5	

5204P

DIN BLANKING PLUG
(REQUIRES 5201 TUBE NUT TO FORM A CAP)

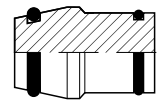

5204P-06	5204P-16	5204P-30
5204P-08	5204P-18	5204P-35
5204P-10	5204P-20	5204P-38
5204P-12	5204P-22	5204P-42
5204P-14	5204P-25	
5204P-15	5204P-28	

STEEL 24° DIN TUBE FITTINGS/ADAPTERS

5300L

FEMALE DIN LIGHT SOFT SEAL UNION

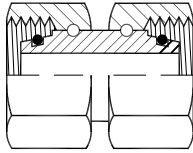

5300L-06	5300L-15	5300L-35
5300L-08	5300L-18	5300L-42
5300L-10	5300L-22	
5300L-12	5300L-28	

5300S

FEMALE DIN HEAVY SOFT SEAL UNION

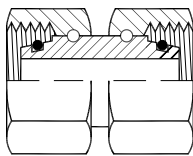

5300S-06	5300S-14	5300S-30
5300S-08	5300S-16	5300S-38
5300S-10	5300S-20	
5300S-12	5300S-25	

5302L

FEMALE DIN LIGHT DUTY X MALE BSP ES SEAL

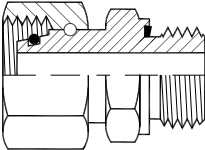

5302L-06-02	5302L-12-06	5302L-22-12
5302L-08-04	5302L-15-08	5302L-28-16
5302L-10-04	5302L-18-08	5302L-35-20
5302L-12-04	5302L-18-12	5302L-42-24

5302S

FEMALE DIN HEAVY DUTY X MALE BSP ES SEAL

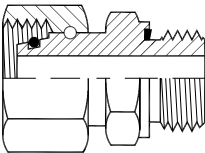

5302S-06-04	5302S-12-08	5302S-25-16
5302S-08-04	5302S-14-08	5302S-30-20
5302S-10-06	5302S-16-08	5302S-38-24
5302S-12-06	5302S-20-12	

5307L

FEMALE DIN LIGHT DUTY X MALE NPT

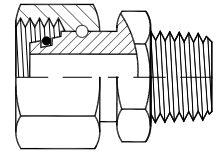

5307L-06-02	5307L-15-08	5307L-35-20
5307L-08-04	5307L-18-08	5307L-42-24
5307L-10-04	5307L-22-12	
5307L-12-06	5307L-28-16	

5307S

FEMALE DIN HEAVY DUTY X MALE NPT

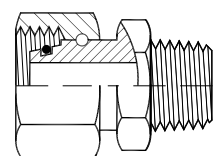

5307S-06-04	5307S-14-08	5307S-30-20
5307S-08-04	5307S-16-08	5307S-38-24
5307S-10-06	5307S-20-12	
5307S-12-06	5307S-25-16	

5309GCL

FEMALE DIN LIGHT DUTY X FEMALE BSP GAUGE COUPLING

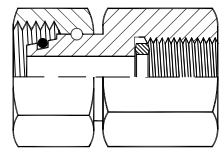

5309GCL-06-04	5309GCL-10-04
5309GCL-08-04	5309GCL-12-04

5309GCS

FEMALE DIN HEAVY DUTY X FEMALE BSP GAUGE COUPLING

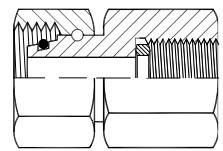

5309GCS-06-08	5309GCS-10-08
5309GCS-08-08	5309GCS-12-08

To order with nut(s) and cutting ring(s) add a "C" to the end of the part number.

STEEL 24° DIN TUBE FITTINGS/ADAPTERS

TUTORIALS

FEATURED

STEEL

STAINLESS STEEL

BRASS

MEALLEABLE IRON QUICK REFERENCE

ABOUT

5315L

FEMALE DIN X MALE DIN
REDUCER LIGHT DUTY

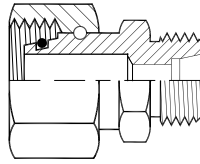

5315L-08-06	5315L-22-08*	5315L-35-15*
5315L-10-06	5315L-22-10*	5315L-35-18*
5315L-10-08	5315L-22-12	5315L-35-22
5315L-12-06	5315L-22-15	5315L-35-28
5315L-12-08	5315L-22-18	5315L-42-06*
5315L-12-10	5315L-28-06*	5315L-42-08*
5315L-15-06	5315L-28-08*	5315L-42-10*
5315L-15-08	5315L-28-10*	5315L-42-12*
5315L-15-10	5315L-28-12*	5315L-42-15*
5315L-15-12	5315L-28-15*	5315L-42-18*
5315L-18-06*	5315L-28-18	5315L-42-22*
5315L-18-08*	5315L-28-22	5315L-42-28*
5315L-18-10*	5315L-35-06*	5315L-42-35
5315L-18-12	5315L-35-08*	
5315L-18-15	5315L-35-10*	
5315L-22-06*	5315L-35-12*	

* min order qty of 200

5315S

FEMALE DIN X MALE DIN
REDUCER HEAVY DUTY

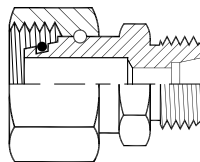

5315S-08-06	5315S-20-08*	5315S-30-14*
5315S-10-06	5315S-20-10*	5315S-30-16*
5315S-10-08	5315S-20-12	5315S-30-20
5315S-12-06*	5315S-20-14*	5315S-30-25*
5315S-12-08	5315S-20-16	5315S-38-06*
5315S-12-10	5315S-25-06*	5315S-38-08*
5315S-14-06*	5315S-25-08*	5315S-38-10*
5315S-14-08*	5315S-25-10*	5315S-38-12*
5315S-14-10	5315S-25-12*	5315S-38-14*
5315S-14-12	5315S-25-14*	5315S-38-16*
5315S-16-06*	5315S-25-16*	5315S-38-20*
5315S-16-08*	5315S-25-20	5315S-38-25
5315S-16-10	5315S-30-06*	5315S-38-30
5315S-16-12	5315S-30-08*	
5315S-16-14	5315S-30-10*	
5315S-20-06*	5315S-30-12*	

* min order qty of 200

5333

GB 37/74 CONVERSION SEAT
FOR MALE DIN

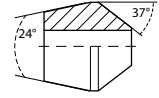

5333-12MM	5333-22MM
5333-14MM	5333-24MM
5333-16MM	5333-30MM
5333-18MM	

COMING 2020!

5333FF

GB FACE SEAL CONVERSION
SEAT FOR MALE DIN

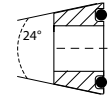

5333FF-12MM	5333FF-22MM
5333FF-14MM	5333FF-24MM
5333FF-16MM	5333FF-30MM
5333FF-18MM	

COMING 2020!

5360L

90° DIN LIGHT DUTY X FEMALE
DIN SWIVEL ELBOW

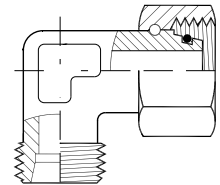

5360L-06	5360L-15	5360L-35
5360L-08	5360L-18	5360L-42
5360L-10	5360L-22	
5360L-12	5360L-28	

5360S

90° DIN HEAVY DUTY X FEMALE
DIN SWIVEL ELBOW

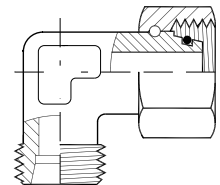

5360S-06	5360S-14	5360S-30
5360S-08	5360S-16	5360S-38
5360S-10	5360S-20	
5360S-12	5360S-25	

STEEL 24° DIN TUBE FITTINGS/ADAPTERS

5362L

45° DIN X FEMALE DIN SWIVEL
LIGHT DUTY ELBOW

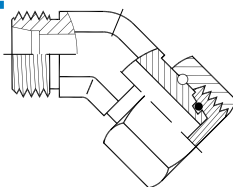

5362L-06	5362L-15	5362L-35
5362L-08	5362L-18	5362L-42
5362L-10	5362L-22	
5362L-12	5362L-28	

5362S

45° DIN X FEMALE DIN SWIVEL
HEAVY DUTY ELBOW

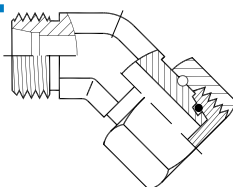

5362S-06	5362S-14	5362S-30
5362S-08	5362S-16	5362S-38
5362S-10	5362S-20	
5362S-12	5362S-25	

5368L

FEMALE DIN LIGHT DUTY X MALE
METRIC ES SEAL

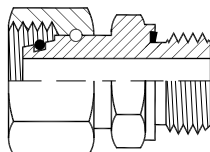

5368L-06-10	5368L-15-18	5368L-35-42
5368L-08-12	5368L-18-22	5368L-42-48
5368L-10-14	5368L-22-26	
5368L-12-16	5368L-28-33	

5368S

FEMALE DIN HEAVY DUTY X
MALE METRIC ES SEAL

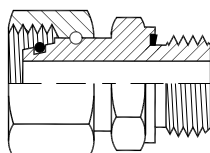

5368S-06-12	5368S-14-20	5368S-30-42
5368S-08-14	5368S-16-22	5368S-38-48
5368S-10-16	5368S-20-27	
5368S-12-18	5368S-25-33	

5387L

FEMALE DIN LIGHT DUTY
SWIVEL BRANCH TEE

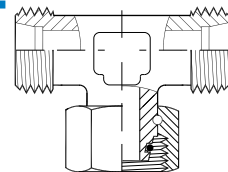

5387L-06	5387L-15	5387L-35
5387L-08	5387L-18	5387L-42
5387L-10	5387L-22	
5387L-12	5387L-28	

5387S

FEMALE DIN HEAVY DUTY
SWIVEL BRANCH TEE

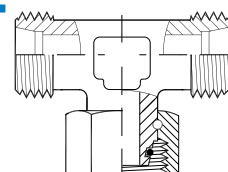

5387S-06	5387S-14	5387S-30
5387S-08	5387S-16	5387S-38
5387S-10	5387S-20	
5387S-12	5387S-25	

5390L

FEMALE DIN LIGHT DUTY
SWIVEL RUN TEE

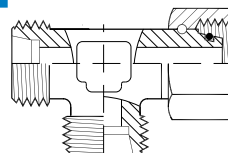

5390L-06	5390L-15	5390L-35
5390L-08	5390L-18	5390L-42
5390L-10	5390L-22	
5390L-12	5390L-28	

5390S

FEMALE DIN HEAVY DUTY
SWIVEL RUN TEE

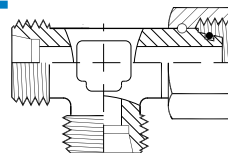

5390S-06	5390S-14	5390S-30
5390S-08	5390S-16	5390S-38
5390S-10	5390S-20	
5390S-12	5390S-25	

To order with nut(s) and cutting ring(s) add a "C" to the end of the part number.

STEEL INTERNATIONAL ADAPTERS

TUTORIALS

3705

90° MALE JIC X FEMALE JIC ELBOW

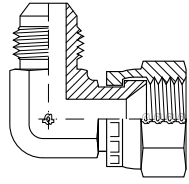

3705-04-04	3705-10-10	3705-24-24
3705-05-05	3705-12-12	
3705-06-06	3705-16-16	
3705-08-08	3705-20-20	

FEATURED

4757

FEMALE JIC RUN TEE

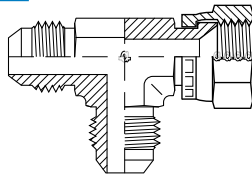

4757-04-04-04	4757-10-10-10	4757-24-24-24
4757-05-05-05	4757-12-12-12	
4757-06-06-06	4757-16-16-16	
4757-08-08-08	4757-20-20-20	

STEEL

STAINLESS STEEL

4775

FEMALE JIC BRANCH TEE

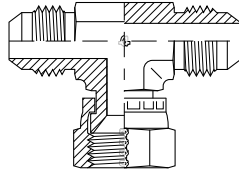

4775-04-04-04	4775-10-10-10	4775-24-24-24
4775-05-05-05	4775-12-12-12	
4775-06-06-06	4775-16-16-16	
4775-08-08-08	4775-20-20-20	

BRASS

MEALLEABLE IRON

QUICK REFERENCE

ABOUT

6002

MALE ORFS X MALE BSPP C/W OR & RR

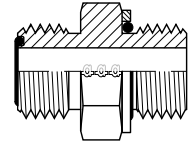

6002-04-02	6002-08-08	6002-16-16
6002-04-04	6002-08-12	6002-20-16
6002-04-06	6002-08-16	6002-20-20
6002-06-04	6002-10-08	6002-24-24
6002-06-06	6002-12-08	
6002-06-08	6002-12-12	
6002-08-04	6002-12-16	
6002-08-06	6002-16-12	

6002L

MALE ORFS X MALE BSPP LONG C/W OR & RR

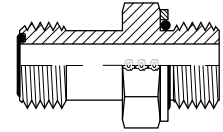

6002L-08-06	6002L-12-12
6002L-08-08	6002L-16-16
6002L-10-08	6002L-20-20
6002L-10-12	

6005

MALE ORFS X MALE BSPP

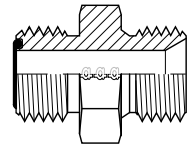

6005-04-02	6005-10-08	6005-20-12
6005-06-04	6005-10-12	6005-20-16
6005-06-06	6005-12-08	6005-20-20
6005-06-08	6005-12-12	6005-24-24
6005-08-04	6005-12-16	
6005-08-06	6005-16-08	
6005-08-08	6005-16-12	
6005-10-06	6005-16-16	

STEEL INTERNATIONAL ADAPTERS

6011

MALE ORFS X MALE BSPT SHORT

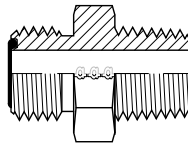

6011-04-04	6011-12-12
6011-06-02	6011-16-16
6011-06-06	6011-20-20
6011-08-08	6011-24-24

6058

45° MALE ORFS X MALE BSPP
ADJUSTABLE ELBOW

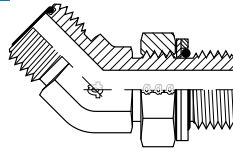

6058-04-02	6058-08-06	6058-16-16
6058-04-04	6058-08-08	
6058-06-04	6058-10-08	
6058-06-06	6058-12-12	

6059

90° ORFS X MALE BSPP
ADJUSTABLE ELBOW

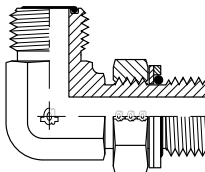

6059-04-02	6059-10-08	6059-20-20
6059-04-04	6059-12-08	6059-20-24
6059-06-04	6059-12-12	6059-24-20
6059-06-06	6059-12-16	6059-24-24
6059-06-08	6059-16-12	
6059-08-04	6059-16-16	
6059-08-06	6059-16-20	
6059-08-08	6059-20-16	

6068

MALE ORFS X MALE METRIC C/W
OR & RR

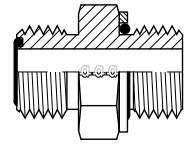

6068-04-10	6068-08-16	6068-12-27
6068-04-12	6068-08-18	6068-16-33
6068-04-14	6068-10-18	
6068-06-12	6068-10-22	
6068-06-14	6068-12-22	
6068-06-16	6068-12-26	

6069

90° MALE ORFS X MALE METRIC
ADJUSTABLE ELBOW

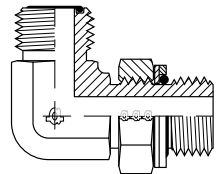

6069-04-10	6069-08-16	6069-20-33
6069-04-12	6069-08-18	
6069-04-14	6069-10-18	
6069-06-14	6069-10-22	
6069-06-16	6069-12-27	
6069-06-18	6069-16-33	

6158

MALE ORFS X MALE BSPP
ADJUSTABLE RUN TEE

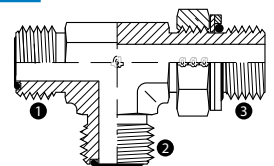

6158-06-06-04	6158-10-10-08
6158-06-06-06	6158-12-12-12
6158-08-08-06	6158-12-12-16
6158-08-08-08	6158-16-16-16

STEEL INTERNATIONAL ADAPTERS

TUTORIALS

FEATURED

STEEL

STAINLESS STEEL

BRASS

MEALLEABLE IRON

QUICK REFERENCE

ABOUT

6159

MALE ORFS X MALE BSPP
ADJUSTABLE BRANCH TEE

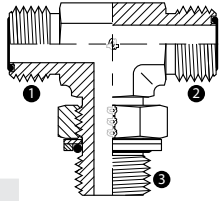

- | | |
|---------------|---------------|
| 6159-04-04-02 | 6159-08-08-06 |
| 6159-04-04-04 | 6159-08-08-08 |
| 6159-06-06-04 | 6159-10-10-08 |
| 6159-06-06-06 | |

6237

MALE ORFS X MALE KOMATSU

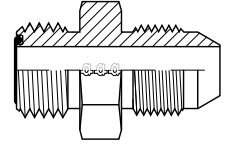

- | | |
|------------|------------|
| 6237-04-14 | 6237-12-30 |
| 6237-06-18 | 6237-16-33 |
| 6237-08-22 | |
| 6237-10-24 | |

6168

MALE ORFS X MALE METRIC
ADJUSTABLE RUN TEE

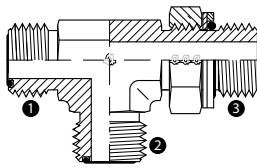

- | | |
|---------------|---------------|
| 6168-04-04-10 | 6168-08-08-16 |
| 6168-04-04-12 | 6168-08-08-18 |
| 6168-06-06-14 | 6168-10-10-22 |
| 6168-06-06-16 | |

6247

MALE ORFS X MALE KOBELCO

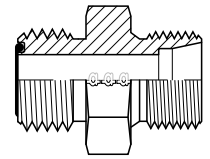

- | | |
|---------------|---------------|
| 6247-12-22-30 | 6247-16-28-36 |
| 6247-12-28-36 | 6247-16-35-45 |

6169

MALE ORFS X MALE METRIC
ADJUSTABLE BRANCH TEE

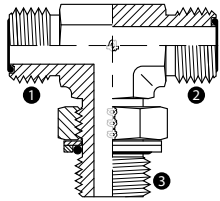

- | | | |
|---------------|---------------|---------------|
| 6169-04-04-10 | 6169-08-08-16 | 6169-10-10-22 |
| 6169-06-06-14 | 6169-08-08-18 | |

6337

MALE ORFS X MALE JIS

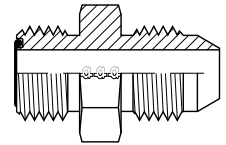

- | | |
|------------|------------|
| 6337-04-04 | 6337-08-08 |
| 6337-06-06 | |

6220

MALE ORFS X FEMALE JIS

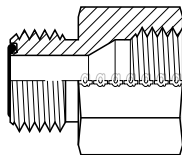

- | | |
|------------|------------|
| 6220-04-04 | 6220-08-08 |
| 6220-06-06 | 6220-12-12 |

6605

MALE ORFS X DIN LIGHT DUTY

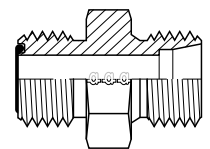

- | | | |
|----------------|----------------|----------------|
| 6605-04-L06-12 | 6605-06-L12-18 | 6605-12-L12-18 |
| 6605-04-L08-14 | 6605-08-L10-16 | 6605-12-L15-22 |
| 6605-06-L08-14 | 6605-08-L12-18 | 6605-12-L18-26 |
| 6605-06-L10-16 | 6605-08-L15-22 | 6605-16-L22-30 |

6230

MALE ORFS X FEMALE KOMATSU

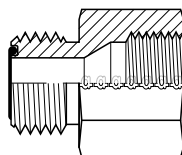

- | | | |
|------------|------------|------------|
| 6230-04-14 | 6230-08-22 | 6230-12-30 |
| 6230-06-18 | 6230-10-24 | 6230-16-33 |

STEEL INTERNATIONAL ADAPTERS

6606

MALE ORFS X DIN HEAVY DUTY

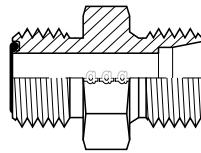

6606-04-S06-14	6606-08-S12-20	6606-12-S25-36
6606-04-S08-16	6606-08-S14-22	6606-16-S25-36
6606-06-S08-16	6606-10-S12-20	6606-16-S30-42
6606-06-S10-18	6606-12-S20-30	

6620

MALE JIC X FEMALE ORFS SWIVEL

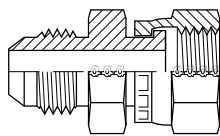

6620-04-04	6620-10-10	6620-24-24
6620-04-06	6620-10-12	
6620-06-04	6620-12-12	
6620-06-06	6620-12-16	
6620-06-08	6620-16-16	
6620-08-08	6620-20-20	

6621

MALE ORFS X FEMALE JIC SWIVEL

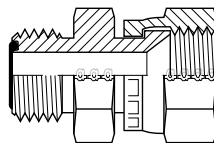

6621-04-04	6621-12-12
6621-06-06	6621-16-16
6621-08-08	6621-20-20
6621-10-10	6621-24-24

6622

MALE ORFS X MALE JIC

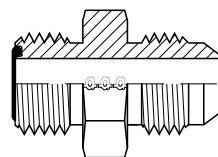

6622-04-04	6622-08-08	6622-20-20
6622-06-04	6622-10-10	6622-24-24
6622-06-06	6622-12-12	
6622-06-08	6622-16-16	

9000

MALE BSPP NIPPLE

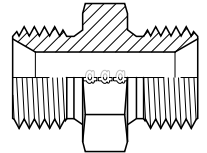

9000-02-02	9000-12-08	9000-24-10
9000-04-02	9000-12-10	9000-24-12
9000-04-04	9000-12-12	9000-24-16
9000-06-02	9000-16-04	9000-24-20
9000-06-04	9000-16-06	9000-24-24
9000-06-06	9000-16-08	9000-32-12
9000-08-02	9000-16-10	9000-32-16
9000-08-04	9000-16-12	9000-32-20
9000-08-06	9000-16-16	9000-32-24
9000-08-08	9000-20-06	9000-32-32
9000-10-04	9000-20-08	9000-40-24
9000-10-06	9000-20-10	9000-40-32
9000-10-08	9000-20-12	9000-40-40
9000-10-10	9000-20-16	9000-48-32
9000-12-04	9000-20-20	9000-48-40
9000-12-06	9000-24-08	9000-48-48

9000TP

MALE BSPP TEST PORT ADAPTER

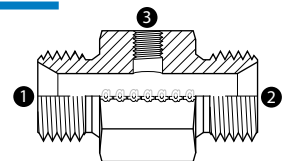

9000TP-04-04-02BSP	9000TP-12-12-02BSP
9000TP-06-06-02BSP	9000TP-12-12-04BSP
9000TP-08-08-02BSP	9000TP-16-16-04BSP
9000TP-08-08-04BSP	9000TP-24-24-04BSP

* Test Port = BSP

STEEL INTERNATIONAL ADAPTERS

TUTORIALS

FEATURED

STEEL

STAINLESS STEEL

BRASS

MEALLEABLE IRON

QUICK REFERENCE

ABOUT

9001

MALE METRIC NIPPLE

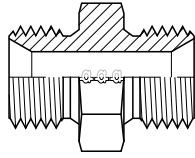

9001-10-10	9001-18-18	9001-24-20
9001-12-10X1.0	9001-20-16	9001-24-22
9001-12-10	9001-20-18	9001-24-24
9001-12-12	9001-20-20	9001-26-18
9001-14-12	9001-22-10X1.0	9001-26-22
9001-14-14	9001-22-14	9001-26-24
9001-16-12	9001-22-16	9001-26-26
9001-16-14	9001-22-18	9001-30-22
9001-16-16	9001-22-20	9001-30X2.0-22
9001-18-12	9001-22-22	9001-30-24
9001-18-14	9001-24-16	9001-30-26
9001-18-16	9001-24-18	9001-30-30

*Default thread pitch = 1.5mm

9002

MALE JIC X MALE BSPP
C/W OR & RR

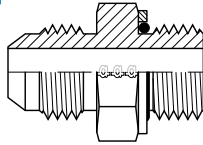

9002-04-02	9002-08-08	9002-20-20
9002-04-04	9002-08-12	9002-20-16
9002-04-06	9002-10-08	9002-24-20
9002-05-04	9002-10-12	9002-24-24
9002-05-06	9002-12-08	9002-32-32
9002-06-04	9002-12-12	
9002-06-06	9002-12-16	
9002-06-08	9002-16-12	
9002-08-04	9002-16-16	
9002-08-06	9002-16-20	

9002L

MALE JIC X MALE BSPP -
LONG C/W OR & RR

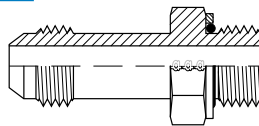

9002L-04-04	9002L-10-08	9002L-20-20
9002L-06-04	9002L-12-12	
9002L-08-06	9002L-12-16	
9002L-08-08	9002L-16-16	

9003

MALE BSPP X MALE BSPT

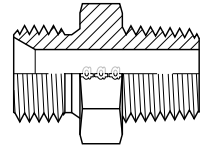

9003-02-02	9003-08-08	9003-16-20
9003-02-04	9003-08-10	9003-16-24
9003-02-06	9003-08-12	9003-16-32
9003-02-08	9003-08-16	9003-20-12
9003-04-02	9003-10-06	9003-20-16
9003-04-04	9003-10-08	9003-20-20
9003-04-06	9003-10-10	9003-20-24
9003-04-08	9003-10-12	9003-20-32
9003-04-12	9003-12-04	9003-24-16
9003-04-16	9003-12-06	9003-24-20
9003-06-02	9003-12-08	9003-24-24
9003-06-04	9003-12-10	9003-24-32
9003-06-06	9003-12-12	9003-32-20
9003-06-08	9003-12-16	9003-32-24
9003-06-10	9003-12-20	9003-32-32
9003-06-12	9003-16-06	9003-40-40
9003-06-16	9003-16-08	9003-48-48
9003-08-02	9003-16-10	
9003-08-04	9003-16-12	
9003-08-06	9003-16-16	

9004

MALE BSPP X MALE METRIC

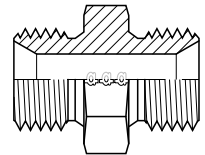

9004-02-10	9004-06-24	9004-12-30
9004-02-12	9004-08-12	9004-12-33X2.0
9004-02-14	9004-08-14	9004-16-18
9004-04-10	9004-08-16	9004-16-22
9004-04-08X1.0	9004-08-18	9004-16-26
9004-04-10X1.0	9004-08-20	9004-16-27X2.0
9004-04-10X1.25	9004-08-22	9004-16-28
9004-04-12	9004-08-24	9004-16-30
9004-04-14	9004-08-26	9004-16-36
9004-04-16	9004-08-27	9004-16-38
9004-04-18	9004-08-28	9004-20-30
9004-04-20	9004-10-22	9004-20-38
9004-04-22	9004-10-26	9004-20-48
9004-04-24	9004-12-16	9004-24-38
9004-06-12	9004-12-18	9004-24-45
9004-06-14	9004-12-20	9004-32-45
9004-06-16	9004-12-22	9004-32-52
9004-06-18	9004-12-24	
9004-06-20	9004-12-26	
9004-06-22	9004-12-27X1.5	

*Default thread pitch = 1.5mm

STEEL INTERNATIONAL ADAPTERS

9005

MALE JIC X MALE BSPP

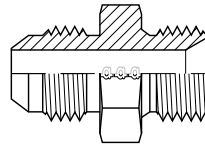

9005-03-04	9005-08-10	9005-16-10
9005-04-02	9005-08-12	9005-16-12
9005-04-04	9005-08-16	9005-16-16
9005-04-06	9005-10-04	9005-16-20
9005-04-08	9005-10-06	9005-16-24
9005-04-12	9005-10-08	9005-16-32
9005-05-02	9005-10-10	9005-20-12
9005-05-04	9005-10-12	9005-20-16
9005-05-06	9005-10-16	9005-20-20
9005-05-08	9005-12-04	9005-20-24
9005-05-10	9005-12-06	9005-24-12
9005-06-02	9005-12-08	9005-24-16
9005-06-04	9005-12-10	9005-24-20
9005-06-06	9005-12-12	9005-24-24
9005-06-08	9005-12-16	9005-24-32
9005-06-10	9005-12-20	9005-32-16
9005-06-12	9005-14-08	9005-32-20
9005-08-04	9005-14-12	9005-32-24
9005-08-06	9005-14-16	9005-32-32
9005-08-08	9005-16-08	9005-32-40

9005ES

MALE JIC X MALE BSPP C/W ELASTOMERIC SEAL

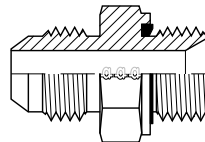

9005ES-04-02	9005ES-08-08	9005ES-16-12
9005ES-04-04	9005ES-08-10	9005ES-16-16
9005ES-04-06	9005ES-08-12	9005ES-16-20
9005ES-04-08	9005ES-08-16	9005ES-16-24
9005ES-05-04	9005ES-10-08	9005ES-20-16
9005ES-06-02	9005ES-10-10	9005ES-20-20
9005ES-06-04	9005ES-10-12	9005ES-20-24
9005ES-06-06	9005ES-12-08	9005ES-24-20
9005ES-06-08	9005ES-12-10	9005ES-24-24
9005ES-06-12	9005ES-12-12	9005ES-32-32
9005ES-08-04	9005ES-12-16	
9005ES-08-06	9005ES-12-20	

9005EL

MALE JIC X MALE BSPP - EXTRA LONG

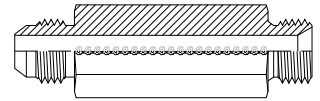

9005EL-04-04	9005EL-08-08
9005EL-06-04	9005EL-12-08
9005EL-06-06	9005EL-12-10
9005EL-08-06	9005EL-12-12

9005L

MALE JIC X MALE BSPP - LONG

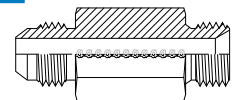

9005L-04-04	9005L-08-06
9005L-06-06	9005L-10-08

9006

MALE SAE ORB X MALE BSPP

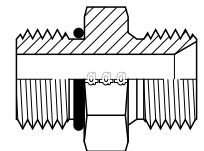

9006-04-02	9006-08-12	9006-16-20
9006-04-04	9006-10-06	9006-20-12
9006-04-06	9006-10-08	9006-20-16
9006-04-08	9006-10-10	9006-20-20
9006-05-04	9006-10-12	9006-20-24
9006-05-06	9006-10-16	9006-24-16
9006-05-08	9006-12-06	9006-24-20
9006-06-04	9006-12-08	9006-24-24
9006-06-06	9006-12-10	9006-24-32
9006-06-08	9006-12-12	9006-32-32
9006-08-04	9006-12-16	
9006-08-06	9006-16-08	
9006-08-08	9006-16-12	
9006-08-10	9006-16-16	

STEEL INTERNATIONAL ADAPTERS

TUTORIALS

FEATURED

STEEL

STAINLESS STEEL

BRASS

MEALLEABLE IRON

QUICK REFERENCE

ABOUT

9007

MALE BSPP X MALE NPT

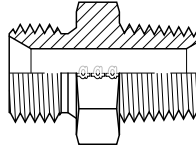

9007-02-02	9007-10-08	9007-24-16
9007-02-04	9007-10-12	9007-24-20
9007-02-06	9007-12-04	9007-24-24
9007-02-08	9007-12-06	9007-24-32
9007-04-02	9007-12-08	9007-32-16
9007-04-04	9007-12-12	9007-32-20
9007-04-06	9007-12-16	9007-32-24
9007-04-08	9007-12-20	9007-32-32
9007-04-12	9007-16-08	9007-32-40
9007-06-02	9007-16-12	9007-32-48
9007-06-04	9007-16-16	9007-40-32
9007-06-06	9007-16-20	9007-40-40
9007-06-08	9007-16-24	9007-40-48
9007-06-12	9007-16-32	9007-48-48
9007-06-16	9007-20-12	9007-64-64
9007-08-04	9007-20-16	
9007-08-06	9007-20-20	
9007-08-08	9007-20-24	
9007-08-12	9007-20-32	
9007-08-16	9007-24-12	

9008

MALE BSPT X MALE NPT

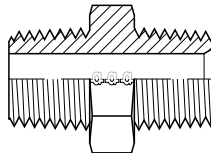

9008-02-02	9008-06-06	9008-32-32
9008-02-04	9008-08-08	9008-40-40
9008-04-02	9008-12-12	9008-48-48
9008-04-04	9008-16-16	
9008-04-06	9008-20-20	
9008-06-04	9008-24-24	

9009

MALE JIC X FEMALE BSP

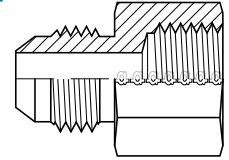

9009-04-02	9009-06-08	9009-12-12
9009-04-04	9009-08-02	9009-12-16
9009-04-06	9009-08-06	9009-16-16
9009-06-02	9009-08-08	9009-20-20
9009-06-04	9009-08-12	9009-24-24
9009-06-06	9009-12-08	9009-32-32

9010

MALE BSPT NIPPLE

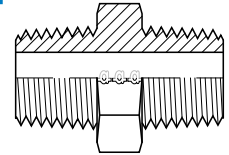

9010-02-02	9010-08-08	9010-20-16
9010-04-02	9010-10-10	9010-20-20
9010-04-04	9010-12-06	9010-24-20
9010-06-02	9010-12-08	9010-24-24
9010-06-04	9010-12-12	9010-32-24
9010-06-06	9010-16-08	9010-32-32
9010-08-04	9010-16-12	9010-40-40
9010-08-06	9010-16-16	9010-48-48

9011

MALE JIC X MALE BSPT

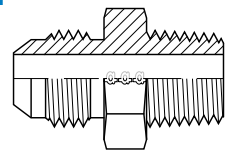

9011-02-04	9011-08-06	9011-16-16
9011-04-02	9011-08-08	9011-16-20
9011-04-04	9011-08-12	9011-20-16
9011-04-06	9011-08-16	9011-20-20
9011-05-02	9011-10-06	9011-20-24
9011-05-04	9011-10-08	9011-24-20
9011-05-06	9011-10-12	9011-24-24
9011-06-02	9011-12-08	9011-24-32
9011-06-04	9011-12-12	9011-32-32
9011-06-06	9011-12-16	
9011-06-08	9011-14-12	
9011-08-04	9011-16-12	

9015

MALE BSPP X FEMALE BSPP SWIVEL

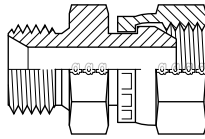

9015-02-02	9015-08-12	9015-16-12
9015-02-04	9015-08-16	9015-16-16
9015-02-06	9015-10-04	9015-16-20
9015-04-02	9015-10-06	9015-16-24
9015-04-04	9015-10-08	9015-20-12
9015-04-06	9015-10-10	9015-20-16
9015-04-08	9015-10-12	9015-20-20
9015-04-12	9015-10-16	9015-20-24
9015-06-04	9015-12-04	9015-20-32
9015-06-06	9015-12-06	9015-24-16
9015-06-08	9015-12-08	9015-24-20
9015-06-10	9015-12-10	9015-24-24
9015-06-12	9015-12-12	9015-24-32
9015-06-16	9015-12-16	9015-32-24
9015-08-04	9015-12-20	9015-32-32
9015-08-06	9015-12-24	
9015-08-08	9015-16-08	
9015-08-10	9015-16-10	

9015TP

BSPP TEST PORT TEE

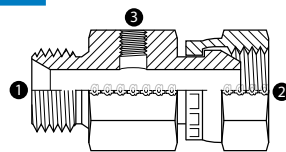

9015TP-02-02-B02	9015TP-12-12-B04
9015TP-04-04-B02	9015TP-16-16-B02
9015TP-06-06-B02	9015TP-16-16-B04
9015TP-06-06-B04	9015TP-20-20-B02
9015TP-08-08-B02	9015TP-20-20-B04
9015TP-12-12-B02	9015TP-24-24-B04

* Test Port = BSP

9017

FEMALE JIC (SWIVEL) X MALE NPT

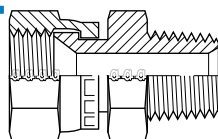

9017-04-02	9017-08-08	9017-20-20
9017-04-04	9017-10-08	9017-24-20
9017-05-04	9017-12-12	9017-24-24
9017-06-04	9017-12-16	
9017-06-06	9017-16-12	
9017-08-06	9017-16-16	

9018

MALE METRIC X FEMALE BSPP SWIVEL

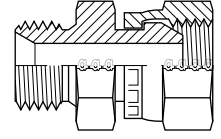

9018-12-04	9018-18-08
9018-14-04	9018-20-08
9018-14-06	9018-22-08
9018-16-06	9018-22-12
9018-16-08	9018-26-08
9018-18-06	9018-26-12

9019

MALE BSPP X FEMALE METRIC SWIVEL

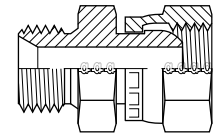

9019-04-L06-12	9019-08-L08-14	9019-12-L15-22
9019-04-L08-14	9019-08-L10-16	9019-12-L18-26
9019-04-L10-16	9019-08-L12-18	9019-12-S12-20
9019-06-L06-12	9019-08-L15-22	
9019-06-L08-14	9019-08-S12-20	
9019-06-L10-16	9019-08-S16-24	
9019-06-L12-18	9019-10-L15-22	
9019-06-S12-20	9019-12-L12-18	

* Mates with both 30° Metric and 24° DIN males

9020

MALE JIC X FEMALE JIC SWIVEL

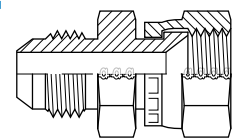

9020-04-04	9020-06-10	9020-12-12
9020-04-06	9020-06-12	9020-12-14
9020-04-08	9020-08-04	9020-12-16
9020-04-10	9020-08-05	9020-12-20
9020-04-12	9020-08-06	9020-12-24
9020-05-04	9020-08-08	9020-16-12
9020-05-05	9020-08-10	9020-16-16
9020-05-06	9020-08-12	9020-16-20
9020-05-08	9020-10-08	9020-16-24
9020-05-12	9020-10-10	9020-20-16
9020-06-04	9020-10-12	9020-20-20
9020-06-05	9020-12-04	9020-20-24
9020-06-06	9020-12-08	9020-24-24
9020-06-08	9020-12-10	9020-32-32

STEEL INTERNATIONAL ADAPTERS

TUTORIALS

FEATURED

STEEL

STAINLESS STEEL

BRASS

MEALLEABLE IRON QUICK REFERENCE

ABOUT

9020C

MALE JIC X FEMALE JIC (SOLID)

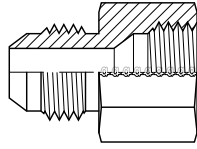

9020C-06-04	9020C-12-10	9020C-32-24
9020C-08-06	9020C-16-12	
9020C-10-08	9020C-20-16	
9020C-12-08	9020C-24-20	

9020TP

MALE JIC X FEMALE JIC TEST PORT TEE

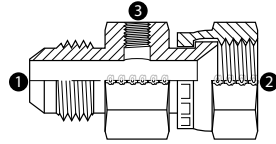

9020TP-04-04-02*	9020TP-12-12-02*
9020TP-08-08-02*	9020TP-16-16-02*
9020TP-08-08-10X1**	
9020TP-10-10-02*	

* BSP Test Port
** Metric Test Port

9021

MALE BSPP X FEMALE JIC SWIVEL

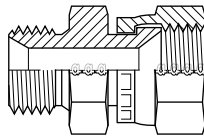

9021-02-04	9021-08-06	9021-12-20
9021-04-04	9021-08-08	9021-16-12
9021-04-05	9021-08-10	9021-16-16
9021-04-06	9021-08-12	9021-16-20
9021-04-08	9021-08-16	9021-20-16
9021-06-04	9021-10-08	9021-20-20
9021-06-05	9021-10-10	9021-20-24
9021-06-06	9021-10-12	9021-24-24
9021-06-08	9021-12-06	9021-32-24
9021-06-10	9021-12-08	9021-32-32
9021-06-12	9021-12-10	
9021-06-16	9021-12-12	
9021-08-04	9021-12-14	
9021-08-05	9021-12-16	

9022

MALE JIC X FEMALE METRIC SWIVEL

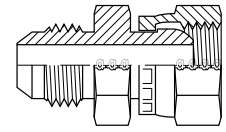

9022-04-L06-12	9022-06-L15-22	9022-10-L12-18
9022-04-L08-14	9022-06-S12-20	9022-10-L15-22
9022-05-L06-12	9022-08-L10-16	9022-10-S12-20
9022-06-L08-14	9022-08-L12-18	9022-12-S20-30
9022-06-L10-16	9022-08-L15-22	
9022-06-L12-18	9022-08-S12-20	

* Mates with both 30° metric and 24° DIN males

9022F

MALE JIC X FEMALE FLAT FACE METRIC (SOLID)

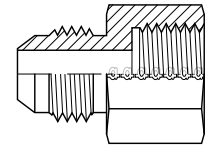

9022F-08-18
9022F-08-22

9022FC

MALE JIC X FEMALE FLAT FACE METRIC SHORT (SOLID)

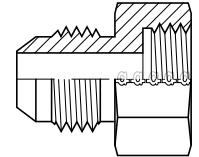

9022FC-04-12	9022FC-08-18
9022FC-04-14	9022FC-08-20
9022FC-06-16	9022FC-08-22
9022FC-06-18	

9023

MALE NPT X FEMALE BSPP SWIVEL

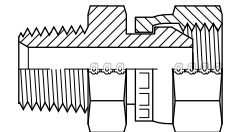

9023-02-02	9023-06-08	9023-16-12
9023-04-02	9023-08-06	9023-16-16
9023-04-04	9023-08-08	
9023-04-06	9023-12-08	
9023-06-04	9023-12-12	
9023-06-06	9023-12-16	

9024

MALE METRIC X FEMALE JIC
SWIVEL

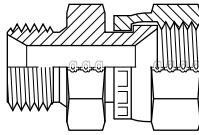

9024-12-05	9024-18-06	9024-22-06
9024-14-06	9024-18-08	9024-22-08
9024-14-08	9024-18-10	9024-22-10
9024-16-06	9024-20-06	
9024-16-08	9024-20-08	
9024-16-10	9024-20-10	

9024S

MALE METRIC (SEALED) X
FEMALE JIC

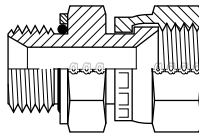

9024S-12-05	9024S-18-08
9024S-14-06	9024S-18-10
9024S-16-06	9024S-20-10
9024S-16-08	9024S-22-06
9024S-16-10	9024S-22-08
9024S-18-06	9024S-22-10

9025

FEMALE BSPP (SWIVEL) UNION

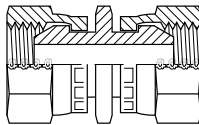

9025-02-02	9025-12-04	9025-20-16
9025-04-02	9025-12-06	9025-20-20
9025-04-04	9025-12-08	9025-24-16
9025-06-04	9025-12-10	9025-24-20
9025-06-06	9025-12-12	9025-24-24
9025-08-04	9025-16-08	9025-32-24
9025-08-06	9025-16-10	9025-32-32
9025-08-08	9025-16-12	
9025-10-08	9025-16-16	
9025-10-10	9025-20-12	

9026

FEMALE JIC (SWIVEL) UNION

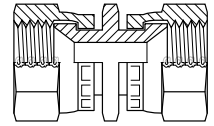

9026-04-04	9026-08-08	9026-16-16
9026-05-04	9026-10-08	9026-20-16
9026-05-05	9026-10-10	9026-20-20
9026-06-04	9026-12-08	9026-24-24
9026-06-05	9026-12-10	9026-32-32
9026-06-06	9026-12-12	
9026-08-04	9026-14-12	
9026-08-06	9026-16-12	

9027

FEMALE BSPP X FEMALE JIC
SWIVEL

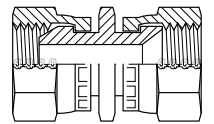

9027-04-04	9027-06-08	9027-12-12
9027-04-05	9027-08-06	9027-12-16
9027-04-06	9027-08-08	9027-16-12
9027-06-04	9027-10-10	9027-16-16
9027-06-05	9027-12-08	9027-20-16
9027-06-06	9027-12-10	9027-20-20

9028

BSPP COUNTERSUNK SEALED
PLUG

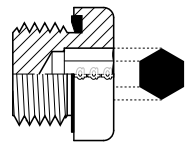

9028-02	9028-12
9028-04	9028-16
9028-06	9028-20
9028-08	9028-24

STEEL INTERNATIONAL ADAPTERS

TUTORIALS

9029

METRIC COUNTERSUNK SEALED PLUG

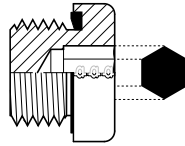

9029-08X1.0	9029-20X1.5	9029-42X2.0
9029-10X1.0	9029-22X1.5	9029-48X2.0
9029-12X1.5	9029-24X1.5	
9029-14X1.5	9029-26X1.5	
9029-16X1.5	9029-27X2.0	
9029-18X1.5	9029-33X2.0	

9030M-ISO

METRIC ISO 6149 HEX PLUG

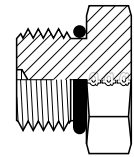

9030M-08X1.0 ISO	9030M-16X1.5 ISO
9030M-10X1.0 ISO	9030M-18X1.5 ISO
9030M-12X1.5 ISO	9030M-22X1.5 ISO
9030M-14X1.5 ISO	9030M-30X2.0 ISO

FEATURED

STEEL

9029A

METRIC COUNTERSUNK PLUG (NO SEAL)

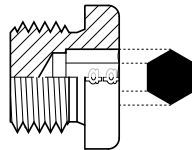

9029-10X1.0A	9029-22X1.5A	9029-38X1.5A
9029-12X1.5A	9029-24X1.5A	9029-42X1.5A
9029-14X1.5A	9029-30X2.0A	9029-42X2.0A
9029-16X1.5A	9029-33X2.0A	9029-48X1.5A
9029-18X1.5A	9029-36X1.5A	
9029-20X1.5A	9029-36X2.0A	

9030T

BSPT HEX PLUG

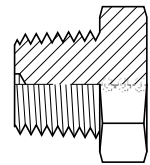

9030T-02	9030T-10	9030T-24
9030T-04	9030T-12	9030T-32
9030T-06	9030T-16	
9030T-08	9030T-20	

STAINLESS STEEL

9030

MALE BSPP HEX PLUG

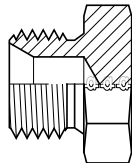

9030-02	9030-16	9030-64
9030-04	9030-20	
9030-06	9030-24	
9030-08	9030-32	
9030-10	9030-40	
9030-12	9030-48	

9030TCSP

BSPT COUNTERSUNK PLUG

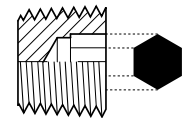

9030TCSP-02	9030TCSP-06	9030TCSP-12
9030TCSP-04	9030TCSP-08	9030TCSP-16

BRASS

MEALLEABLE IRON

9030M

METRIC HEX PLUG

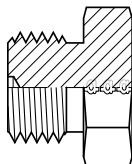

9030M-08X1.0	9030M-16X1.5	9030M-30X1.5
9030M-10X1.0	9030M-18X1.5	9030M-36X2.0
9030M-10X1.5	9030M-20X1.5	
9030M-12X1.0	9030M-22X1.5	
9030M-12X1.5	9030M-24X1.5	
9030M-14X1.5	9030M-26X1.5	

9031

MALE BSPT X FEMALE BSPT BUSHING

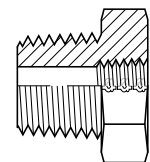

9031-04-02	9031-12-08	9031-32-32
9031-06-02	9031-16-08	
9031-06-04	9031-16-12	
9031-08-04	9031-20-08	
9031-08-06	9031-24-16	
9031-12-06	9031-32-24	

QUICK REFERENCE

ABOUT

STEEL INTERNATIONAL ADAPTERS

9032

MALE BSPT X FEMALE BSP

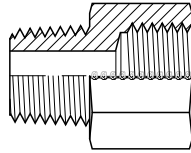

9032-02-02	9032-08-08	9032-20-16
9032-02-04	9032-12-04	9032-20-20
9032-04-02	9032-12-06	9032-24-20
9032-04-04	9032-12-08	9032-32-16
9032-04-06	9032-12-12	9032-32-20
9032-06-02	9032-16-08	
9032-06-04	9032-16-12	
9032-06-06	9032-16-16	

9034

MALE BSPP X FEMALE BSPT

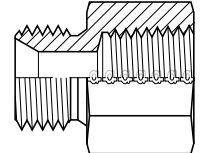

9034-04-02	9034-06-04	9034-08-08
9034-04-04	9034-06-06	9034-12-12

9032S

MALE BSPT X FEMALE BSPP SWIVEL

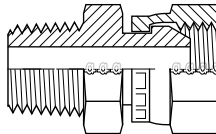

9032S-04-04	9032S-12-12
9032S-06-06	9032S-16-16
9032S-08-06	9032S-20-20
9032S-08-08	9032S-24-24

9033

BSPP SWIVEL CAP

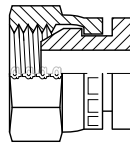

9033-02	9033-10	9033-24
9033-04	9033-12	9033-32
9033-06	9033-16	
9033-08	9033-20	

9033F

BSPP SOLID CAP

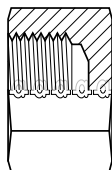

9033F-02	9033F-10	9033F-24
9033F-04	9033F-12	9033F-32
9033F-06	9033F-16	
9033F-08	9033F-20	

9035

MALE BSPP X FEMALE NPT

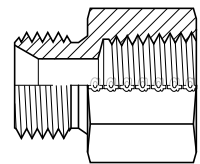

9035-02-02	9035-10-08	9035-24-16
9035-02-04	9035-12-04	9035-24-20
9035-04-02	9035-12-06	9035-24-24
9035-04-04	9035-12-08	9035-24-32
9035-04-06	9035-12-12	9035-32-12
9035-04-08	9035-12-16	9035-32-24
9035-06-02	9035-16-04	9035-32-32
9035-06-04	9035-16-06	9035-40-24
9035-06-06	9035-16-08	9035-40-32
9035-06-08	9035-16-12	9035-40-40
9035-08-02	9035-16-16	9035-40-48
9035-08-04	9035-20-08	9035-48-32
9035-08-06	9035-20-12	9035-48-48
9035-08-08	9035-20-16	
9035-08-12	9035-20-20	
9035-10-06	9035-24-12	

9035S

MALE BSPP X FEMALE NPT C/W OR & RR

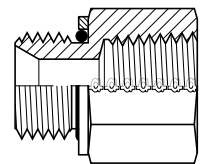

9035S-02-02	9035S-08-08	9035S-32-32
9035S-04-02	9035S-12-08	
9035S-04-04	9035S-12-12	
9035S-06-04	9035S-16-16	
9035S-06-06	9035S-20-20	
9035S-08-06	9035S-24-24	

STEEL INTERNATIONAL ADAPTERS

TUTORIALS

FEATURED

STEEL

STAINLESS STEEL

BRASS

MEALLEABLE IRON

QUICK REFERENCE

ABOUT

9036

MALE BSPP X FEMALE SAE ORB (SOLID)

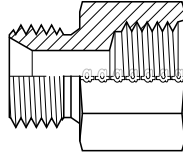

9036-02-04	9036-08-10
9036-04-04	9036-12-12
9036-04-06	9036-12-16
9036-06-06	9036-16-16
9036-06-08	9036-20-20
9036-08-08	9036-24-24

9038ES

MALE BSPP X FEMALE BSP BUSHING ES SEALED

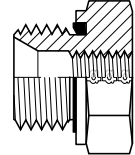

9038-06-02ES	9038-20-08ES	9038-32-20ES
9038-08-04ES	9038-20-12ES	
9038-12-04ES	9038-20-16ES	
9038-12-06ES	9038-24-08ES	
9038-12-08ES	9038-24-12ES	
9038-16-04ES	9038-24-16ES	

9037

MALE NPT X FEMALE BSP

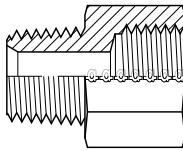

9037-02-02	9037-12-06	9037-24-20
9037-02-04	9037-12-08	9037-24-24
9037-04-02	9037-12-12	9037-32-20
9037-04-04	9037-12-16	9037-32-32
9037-04-06	9037-16-04	9037-40-40
9037-04-08	9037-16-06	9037-48-48
9037-06-04	9037-16-08	
9037-06-06	9037-16-12	
9037-08-04	9037-16-16	
9037-08-06	9037-20-08	
9037-08-08	9037-20-20	
9037-12-04	9037-24-16	

9039

MALE BSPP X FEMALE BSP EXTENDED BUSHING

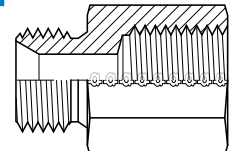

9039-02-02	9039-06-16	9039-16-12
9039-02-04	9039-08-06	9039-16-16
9039-02-06	9039-08-08	9039-16-20
9039-02-08	9039-08-10	9039-16-24
9039-04-02	9039-08-12	9039-16-32
9039-04-04	9039-08-16	9039-20-20
9039-04-06	9039-08-20	9039-20-32
9039-04-08	9039-10-08	9039-24-20
9039-04-10	9039-12-08	9039-24-24
9039-04-12	9039-12-10	9039-32-24
9039-06-04	9039-12-12	9039-32-32
9039-06-06	9039-12-16	
9039-06-08	9039-12-20	
9039-06-12	9039-12-24	

9038

MALE BSPP X FEMALE BSP BUSHING

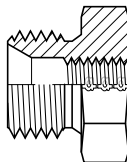

9038-06-02	9038-16-08	9038-24-12
9038-08-02	9038-16-10	9038-24-16
9038-08-04	9038-20-06	9038-32-08
9038-10-06	9038-20-08	9038-32-12
9038-12-04	9038-20-12	9038-32-16
9038-12-06	9038-20-16	9038-32-20
9038-16-04	9038-24-06	9038-32-24
9038-16-06	9038-24-08	9038-40-32

9039ES

MALE BSPP X FEMALE BSP EXTENDED BUSHING ES SEALED

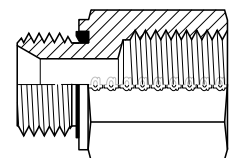

9039-02-04ES	9039-06-04ES	9039-24-20ES
9039-02-06ES	9039-06-06ES	
9039-04-02ES	9039-08-12ES	
9039-04-06ES	9039-12-16ES	

STEEL INTERNATIONAL ADAPTERS

9040

MALE BSPP X MALE BSPP
BULKHEAD

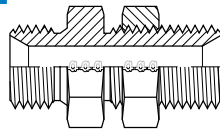

9040-02-02	9040-08-12	9040-20-20
9040-04-04	9040-10-10	9040-20-24
9040-04-06	9040-12-06	9040-24-24
9040-06-04	9040-12-08	9040-32-32
9040-06-06	9040-12-12	
9040-06-08	9040-12-16	
9040-08-06	9040-16-12	
9040-08-08	9040-16-16	

9040L

MALE BSPP X MALE BSPP
BULKHEAD LONG

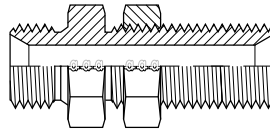

9040-04-04L-2.25"	9040-06-06L-2.5"	9040-16-16L-3.25"
9040-04-04L-2.5"	9040-08-06L-2.75"	
9040-04-04L-3.14"	9040-08-06L-2.87"	
9040-04-06L-1.85"	9040-08-08L-2.75"	

9040M

MALE BSPP X MALE METRIC
BULKHEAD

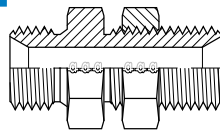

9040M-06-14	9040M-06-18
9040M-06-16	9040M-08-22

9041

BSPP BULKHEAD LOCKNUT

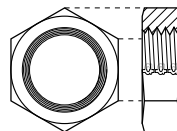

9041-02	9041-10	9041-24
9041-04	9041-12	9041-32
9041-06	9041-16	
9041-08	9041-20	

9042

MALE BSPT X FEMALE NPT

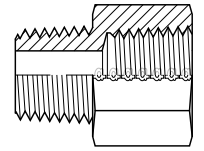

9042-02-02	9042-12-04	9042-20-40
9042-02-04	9042-12-06	9042-24-16
9042-04-02	9042-12-08	9042-24-20
9042-04-04	9042-12-12	9042-24-24
9042-04-06	9042-16-04	9042-32-32
9042-06-02	9042-16-12	9042-48-48
9042-06-04	9042-16-16	
9042-06-06	9042-20-12	
9042-08-04	9042-20-16	
9042-08-08	9042-20-20	

9043

FEMALE BSP X FEMALE BSP
(SOLID)

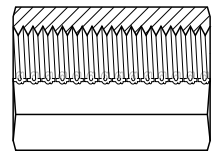

9043-02-02	9043-12-04	9043-20-20
9043-04-02	9043-12-06	9043-24-16
9043-04-04	9043-12-08	9043-24-24
9043-06-02	9043-12-10	9043-32-24
9043-06-04	9043-12-12	9043-32-32
9043-06-06	9043-16-06	
9043-08-02	9043-16-08	
9043-08-06	9043-16-12	
9043-08-08	9043-16-16	
9043-10-06	9043-20-08	
9043-10-08	9043-20-12	
9043-10-10	9043-20-16	

STEEL INTERNATIONAL ADAPTERS

TUTORIALS

FEATURED

STEEL

STAINLESS STEEL

BRASS

MEALLEABLE IRON

QUICK REFERENCE

ABOUT

9043M

FEMALE METRIC X FEMALE METRIC (SOLID)

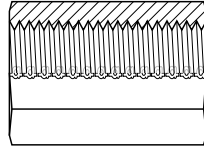

9043M-12-12	9043M-16-16	9043M-22-22
9043M-14-10	9043M-18-18	9043M-30-30
9043M-14-14	9043M-20-20	
9043M-16-12	9043M-22-16	

9044

FEMALE BSP X FEMALE NPT (SOLID)

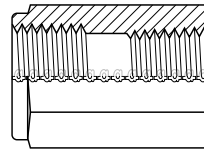

9044-02-02	9044-08-08	9044-24-24
9044-04-04	9044-12-08	9044-32-32
9044-06-04	9044-12-12	9044-40-40
9044-06-06	9044-12-16	9044-48-48
9044-08-04	9044-16-16	
9044-08-06	9044-20-20	

9045

90° MALE BSPP X FEMALE BSPP (SWIVEL) TUBE ELBOW

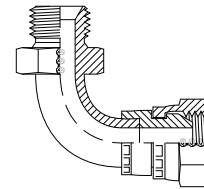

9045-04-04	9045-12-12	9045-32-32
9045-06-06	9045-16-16	
9045-08-08	9045-20-20	
9045-10-10	9045-24-24	

9046

90° FEMALE BSPP (SWIVEL) X MALE BSPP ADJ. ELBOW

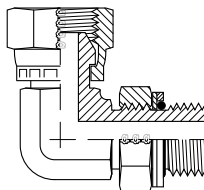

9046-04-04	9046-08-08	9046-16-16
9046-06-06	9046-12-12	

9047

45° MALE BSPP X FEMALE BSPP (SWIVEL) TUBE ELBOW

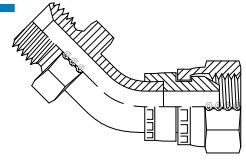

9047-04-04	9047-12-12
9047-06-06	9047-16-16
9047-08-08	9047-20-20
9047-10-10	

9048

45° MALE BSPP X FEMALE BSPP (SWIVEL) ELBOW

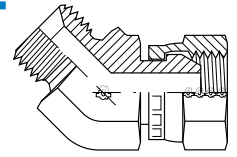

9048-04-04	9048-08-08	9048-16-16
9048-06-06	9048-12-12	

9050

90° FEMALE BSPP (SWIVEL) X FEMALE BSPP (SWIVEL) TUBE ELBOW

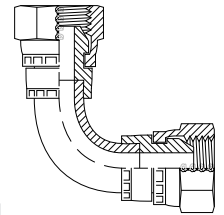

9050-04-04	9050-12-12
9050-06-06	9050-16-16
9050-08-08	9050-20-20
9050-10-10	9050-24-24

9051

45° MALE BSPP X MALE BSPP ADJ. ELBOW

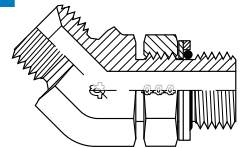

9051-04-04	9051-08-08
9051-06-04	9051-12-08
9051-06-06	9051-12-12
9051-08-06	9051-16-16

STEEL INTERNATIONAL ADAPTERS

9052

90° MALE BSPP X ADJ. MALE BSPP ELBOW

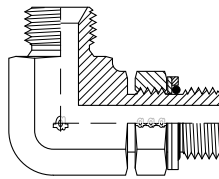

9052-04-04	9052-06-08	9052-12-08
9052-04-06	9052-08-06	9052-12-12
9052-06-04	9052-08-08	9052-16-16
9052-06-06	9052-08-12	9052-20-20

9053

45° FEMALE BSPP (SWIVEL) X FEMALE BSPP (SWIVEL) TUBE ELBOW

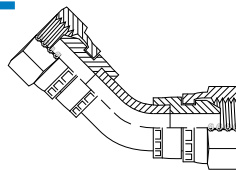

9053-04-04	9053-12-12
9053-06-06	9053-16-16
9053-08-08	9053-20-20
9053-10-10	

9054

45° MALE BSPP X MALE BSPT ELBOW

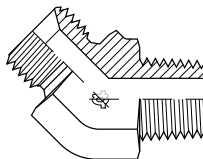

9054-04-02	9054-06-06	9054-16-16
9054-04-04	9054-08-06	
9054-04-06	9054-08-08	
9054-06-04	9054-12-12	

9055

90° MALE BSPP X MALE BSPP ELBOW

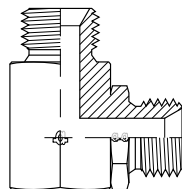

9055-02-02*	9055-10-10*	9055-20-20
9055-04-04*	9055-12-08	9055-24-24
9055-06-04	9055-12-10	9055-32-32
9055-06-06*	9055-12-12*	
9055-08-06	9055-16-12	
9055-08-08*	9055-16-16*	

* FORGED BODY

9056

90° MALE JIC X FEMALE BSPP (SWIVEL) ELBOW

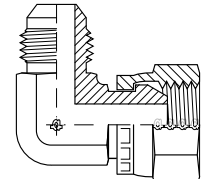

9056-04-04	9056-08-06	9056-12-12
9056-06-06	9056-08-08	9056-16-16

9057

90° MALE BSPP X MALE BSPT ELBOW

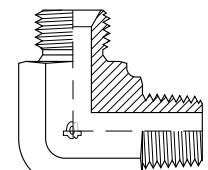

9057-02-02	9057-06-08	9057-16-16
9057-04-02	9057-08-06	
9057-04-04	9057-08-08	
9057-04-06	9057-10-10	
9057-06-04	9057-12-12	
9057-06-06	9057-12-16	

9058

45° MALE JIC X MALE BSPP ADJ. ELBOW

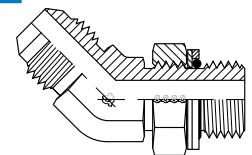

9058-04-02	9058-08-06	9058-12-12
9058-04-04	9058-08-08	9058-16-16
9058-06-04	9058-10-08	
9058-06-06	9058-12-08	

9059

90° MALE JIC X MALE BSPP ADJ. ELBOW

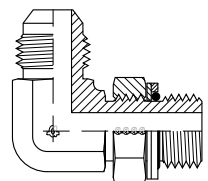

9059-04-02	9059-08-04	9059-12-12
9059-04-04	9059-08-06	9059-12-16
9059-04-06	9059-08-08	9059-16-12
9059-05-04	9059-08-12	9059-16-16
9059-05-06	9059-10-06	9059-16-20
9059-06-04	9059-10-08	9059-20-16
9059-06-06	9059-10-12	9059-20-20
9059-06-08	9059-12-08	9059-24-24

TUTORIALS

FEATURED

STEEL

STAINLESS STEEL

BRASS

MEALLEABLE IRON

QUICK REFERENCE

ABOUT

STEEL INTERNATIONAL ADAPTERS

TUTORIALS

FEATURED

STEEL

STAINLESS STEEL

BRASS

MEALLEABLE IRON

QUICK REFERENCE

ABOUT

9059L

90° MALE JIC X MALE BSPP
ADJ. LONG ELBOW

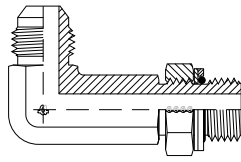

- | | |
|-------------|-------------|
| 9059L-06-06 | 9059L-08-08 |
| 9059L-08-06 | |

9060

90° MALE BSPP X FEMALE BSPP
(SWIVEL) ELBOW

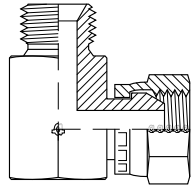

- | | | |
|-------------|-------------|-------------|
| 9060-02-02* | 9060-08-06 | 9060-16-12 |
| 9060-04-04* | 9060-08-08* | 9060-16-16* |
| 9060-04-06 | 9060-10-10 | 9060-20-20 |
| 9060-06-04 | 9060-12-08 | 9060-24-24 |
| 9060-06-06* | 9060-12-12* | 9060-32-32 |
| 9060-06-08 | 9060-12-16 | |

* FORGED BODY

9061

90° MALE BSPP X FEMALE JIC
(SWIVEL) ELBOW

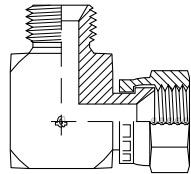

- | | | |
|------------|------------|------------|
| 9061-04-04 | 9061-08-06 | 9061-12-12 |
| 9061-04-06 | 9061-08-08 | |
| 9061-06-06 | 9061-08-10 | |
| 9061-06-08 | 9061-10-10 | |

9062

90° MALE BSPT X FEMALE BSPP
(SWIVEL) ELBOW

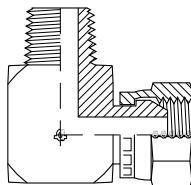

- | | |
|------------|------------|
| 9062-02-02 | 9062-08-08 |
| 9062-04-04 | 9062-12-12 |
| 9062-06-04 | 9062-16-16 |
| 9062-06-06 | |

9063

90° MALE JIC X MALE BSPT
ELBOW

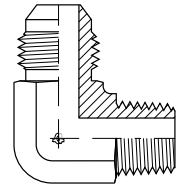

- | | | |
|------------|------------|------------|
| 9063-04-02 | 9063-08-08 | 9063-24-24 |
| 9063-04-04 | 9063-10-08 | 9063-32-32 |
| 9063-05-02 | 9063-12-08 | |
| 9063-05-04 | 9063-12-12 | |
| 9063-06-04 | 9063-12-16 | |
| 9063-06-06 | 9063-16-12 | |
| 9063-06-08 | 9063-16-16 | |
| 9063-08-06 | 9063-20-20 | |

9064

45° MALE JIC X MALE BSPT
ELBOW

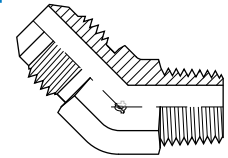

- | | | |
|------------|------------|------------|
| 9064-04-02 | 9064-08-06 | 9064-16-12 |
| 9064-04-04 | 9064-08-08 | 9064-16-16 |
| 9064-06-04 | 9064-10-08 | 9064-20-20 |
| 9064-06-06 | 9064-12-12 | |

9065

90° MALE JIC X MALE BSPP
ELBOW

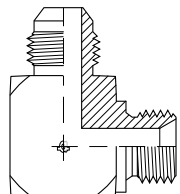

- | | | |
|------------|------------|------------|
| 9065-04-04 | 9065-08-08 | 9065-12-16 |
| 9065-05-04 | 9065-10-08 | 9065-16-16 |
| 9065-06-04 | 9065-10-12 | 9065-20-20 |
| 9065-06-06 | 9065-12-10 | |
| 9065-08-06 | 9065-12-12 | |

9066

45° MALE JIC X MALE METRIC
ADJ ELBOW

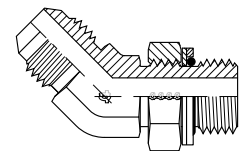

- | | | |
|------------|------------|------------|
| 9066-04-10 | 9066-08-16 | 9066-12-22 |
| 9066-04-12 | 9066-08-18 | 9066-12-27 |
| 9066-06-14 | 9066-10-18 | 9066-16-33 |
| 9066-06-16 | 9066-10-22 | |

STEEL INTERNATIONAL ADAPTERS

9067

MALE JIC X MALE METRIC

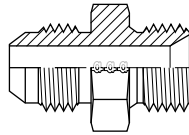

9067-02-10	9067-08-12	9067-10-22
9067-04-12	9067-08-14	9067-10-26
9067-04-14	9067-08-16	9067-12-16
9067-04-16	9067-08-18	9067-12-18
9067-06-12	9067-08-20	9067-12-24
9067-06-14	9067-08-22	9067-12-26
9067-06-16	9067-10-14	9067-12-27X1.5
9067-06-18	9067-10-16	
9067-06-20	9067-10-18	
9067-06-22	9067-10-20	

9068

MALE JIC X MALE METRIC C/W OR & RR

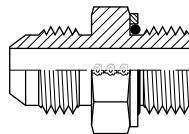

9068-04-10	9068-08-14	9068-16-27
9068-04-12	9068-08-16	9068-16-33
9068-04-14	9068-08-18	9068-20-33
9068-05-12	9068-08-22	9068-20-42
9068-05-16	9068-10-18	9068-24-48
9068-06-12	9068-10-20	
9068-06-14	9068-10-22	
9068-06-16	9068-12-22	
9068-06-18	9068-12-26	
9068-08-12	9068-12-27	

9069

90° MALE JIC X MALE METRIC ADJ. ELBOW

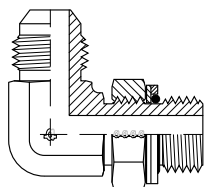

9069-04-10	9069-08-16	9069-12-30X1.5
9069-04-12	9069-08-18	9069-16-27
9069-04-14	9069-08-20	9069-16-33
9069-05-10	9069-08-22	9069-20-42
9069-05-12	9069-10-18	9069-24-48
9069-05-14	9069-10-20	
9069-06-12	9069-10-22	
9069-06-14	9069-12-22	
9069-06-16	9069-12-26	
9069-06-18	9069-12-27	

9069L

90° MALE JIC X MALE METRIC ADJ. LONG ELBOW

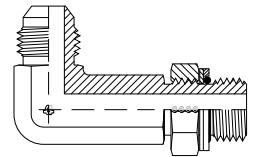

9069L-08-18
9069L-10-22

9070

90° MALE BSPP X MALE NPT ELBOW

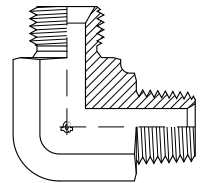

9070-02-02	9070-12-12
9070-04-04	9070-16-12
9070-06-06	9070-16-16
9070-08-08	

9072

90° MALE NPT X FEMALE BSPP (SWIVEL) ELBOW

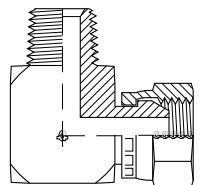

9072-02-02	9072-12-12
9072-04-04	9072-16-16
9072-06-06	9072-20-20
9072-08-08	9072-24-24

9075

90° FEMALE BSPP X FEMALE BSPP (SWIVEL) ELBOW

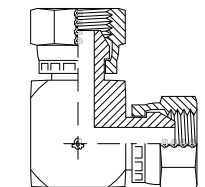

9075-02-02	9075-10-10	9075-32-32
9075-04-04	9075-12-12	
9075-06-04	9075-16-12	
9075-06-06	9075-16-16	
9075-08-06	9075-20-20	
9075-08-08	9075-24-24	

STEEL INTERNATIONAL ADAPTERS

TUTORIALS

FEATURED

STEEL

STAINLESS STEEL

BRASS

MEALLEABLE IRON

QUICK REFERENCE

ABOUT

9076

90° FEMALE BSP X FEMALE BSP (SOLID) ELBOW

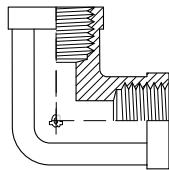

9076-04-04	9076-16-16
9076-06-06	9076-20-20
9076-08-08	9076-24-24
9076-12-12	

9077

90° MALE BSPP X MALE ORB ADJ. ELBOW

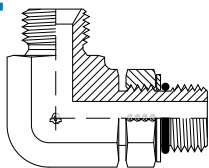

9077-02-04	9077-08-08
9077-04-06	9077-08-10
9077-06-06	9077-12-12
9077-06-08	9077-16-16

9078

MALE BSPP X MALE ORB ADJ. RUN TEE

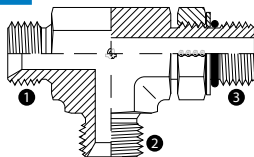

9078-02-02-04	9078-08-08-10	9078-12-12-12
9078-06-06-08	9078-12-12-10	9078-16-16-16

9079

MALE BSPP X MALE ORB ADJ. BRANCH TEE

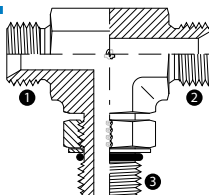

9079-02-02-04	9079-08-08-08	9079-12-12-12
9079-06-06-08	9079-08-08-10	9079-16-16-16

9080

MALE BSPP TEE

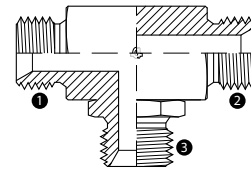

9080-02-02-02	9080-08-08-08*	9080-16-16-08
9080-04-04-04*	9080-08-08-12	9080-16-16-16
9080-04-04-06	9080-10-10-10	9080-20-20-20
9080-06-06-04	9080-12-12-08	9080-24-24-24
9080-06-06-06*	9080-12-12-12	9080-32-32-32
9080-06-06-08	9080-12-12-16	

* FORGED BODY

9085

FEMALE BSPP SWIVEL TEE

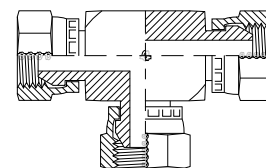

9085-02-02-02	9085-10-10-10	9085-24-24-24
9085-04-04-04	9085-12-12-12	9085-32-32-32
9085-06-06-06*	9085-16-16-16	
9085-08-08-08*	9085-20-20-20	

* FORGED BODY

9086

FEMALE BSP SOLID TEE

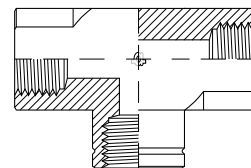

9086-02-02-02*	9086-10-10-10
9086-04-04-04*	9086-12-12-12
9086-06-06-06*	9086-16-16-16
9086-08-08-08*	9086-20-20-20

* FORGED BODY

9087

FEMALE BSPP (SWIVEL) BRANCH TEE

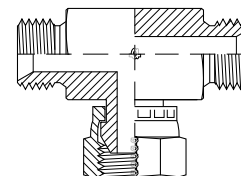

9087-02-02-02	9087-10-10-10	9087-24-24-24
9087-04-04-04*	9087-12-12-12*	
9087-06-06-06*	9087-16-16-16	
9087-08-08-08*	9087-20-20-20	

* FORGED BODY

STEEL INTERNATIONAL ADAPTERS

9090

FEMALE BSPP (SWIVEL)
RUN TEE

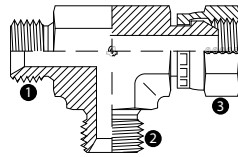

9090-02-02-02	9090-06-08-08	9090-16-16-16*
9090-04-04-04*	9090-08-08-08*	9090-20-20-20*
9090-04-06-06	9090-10-10-10*	9090-24-24-24
9090-06-04-06	9090-12-12-06	
9090-06-06-04	9090-12-12-08	
9090-06-06-06*	9090-12-12-12*	

* FORGED BODY

9095

MALE BSPP (SWIVEL) RUN TEE

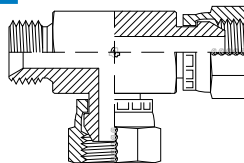

9095-02-02-02	9095-10-10-10
9095-04-04-04*	9095-12-12-12*
9095-06-06-06*	9095-16-16-16
9095-08-08-08*	9095-20-20-20

* FORGED BODY

9096

MALE BSPP CROSS

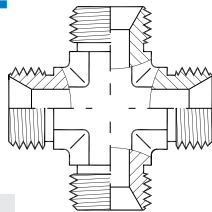

9096-04	9096-16
9096-06	9096-20
9096-08	9096-24
9096-12	

9097

FEMALE BSP CROSS (SOLID)

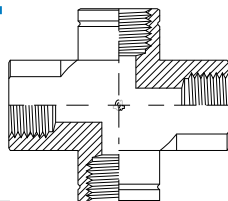

9097-04	9097-16
9097-08	9097-20

9120

MALE ORB X FEMALE BSP

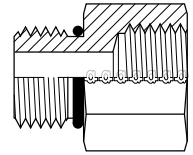

9120-04-04	9120-06-06	9120-12-08
9120-06-04	9120-08-04	

9135

90° MALE BSPP ADJ. X FEMALE
NPT ELBOW

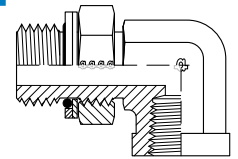

9135-02-02	9135-06-06	9135-16-16
9135-04-02	9135-08-06	9135-20-20
9135-04-04	9135-08-08	9135-24-24
9135-06-04	9135-12-12	

9151

MALE BSPP ADJ. RUN TEE

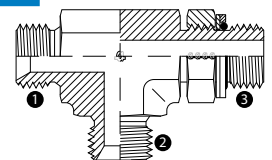

9151-04-04-04	9151-06-06-06	9151-08-08-08
9151-06-06-04	9151-08-08-06	9151-12-12-12

9152

MALE BSPP ADJ. BRANCH TEE

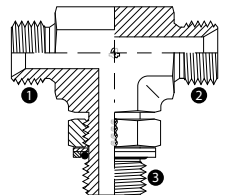

9152-04-04-04	9152-06-06-06	9152-08-08-08
9152-06-06-04	9152-08-08-06	9152-12-12-12

9158

MALE JIC X MALE BSPP
RUN TEE

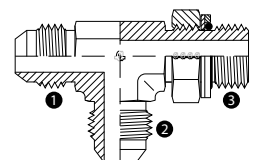

9158-04-04-04	9158-08-08-06	9158-16-16-16
9158-05-05-04	9158-08-08-08	9158-20-20-20
9158-06-06-04	9158-10-10-08	
9158-06-06-06	9158-12-12-12	

STEEL INTERNATIONAL ADAPTERS

TUTORIALS

FEATURED

STEEL

STAINLESS STEEL

BRASS

MEALLEABLE IRON

QUICK REFERENCE

ABOUT

9159

MALE JIC X MALE BSPP
BRANCH TEE

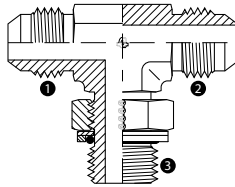

9159-04-04-04	9159-08-08-06	9159-16-16-16
9159-05-05-04	9159-08-08-08	
9159-06-06-04	9159-10-10-08	
9159-06-06-06	9159-12-12-12	

9163

MALE JIC X MALE BSPT
RUN TEE

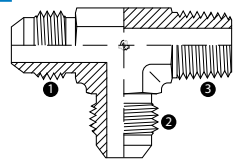

9163-04-04-04	9163-08-08-06	9163-12-12-12
9163-06-06-04	9163-10-10-08	

9164

MALE JIC X MALE BSPT
BRANCH TEE

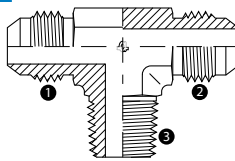

9164-06-06-04	9164-12-12-12
9164-10-10-08	

9168

MALE JIC X MALE METRIC
RUN TEE

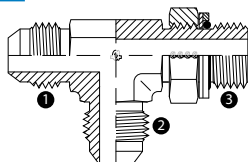

9168-04-04-12	9168-08-08-16	9168-10-10-22
9168-06-06-14	9168-08-08-18	9168-12-12-27

9169

MALE JIC X MALE METRIC
BRANCH TEE

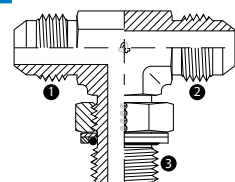

9169-04-04-10	9169-08-08-18
9169-04-04-12	9169-10-10-22
9169-06-06-14	9169-12-12-27
9169-08-08-16	9169-16-16-33

9197

MALE JIC X FEMALE
METRIC DIN/DKO (SWIVEL)

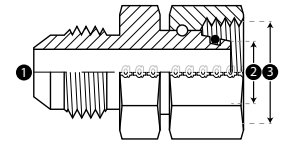

9197-04-L06-12	9197-08-S12-20	9197-16-L28-36
9197-04-L08-14	9197-08-S16-24	9197-16-S25-36
9197-04-S06-14	9197-10-L15-22	9197-20-L35-45
9197-06-L08-14	9197-10-S16-24	9197-20-S30-42
9197-06-L10-16	9197-12-L18-26	9197-24-L42-52
9197-06-S08-16	9197-12-L22-30	9197-24-S38-52
9197-06-S10-18	9197-12-S20-30	
9197-08-L12-18	9197-16-L22-30	

9199

90° MALE JIC X FEMALE METRIC
DIN/DKO (SWIVEL) ELBOW

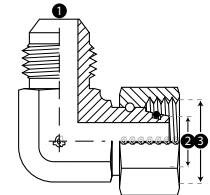

9199-04-L06-12	9199-08-L12-18	9199-16-L22-30
9199-04-S06-14	9199-08-S12-20	9199-16-L28-36
9199-06-L08-14	9199-10-L15-22	9199-16-S25-36
9199-06-L10-16	9199-10-S16-24	9199-20-L35-45
9199-06-S08-16	9199-12-L18-26	9199-20-S30-42
9199-06-S10-18	9199-12-S20-30	9199-24-L42-52

9200

MALE JIC X DIN STANDPIPE

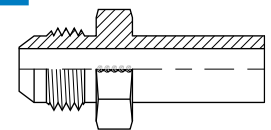

9200-03-04	9200-08-14	9200-16-28
9200-04-04	9200-08-15	9200-16-30
9200-04-06	9200-08-16	9200-20-28
9200-04-08	9200-10-16	9200-20-35
9200-04-10	9200-10-18	9200-20-38
9200-05-12	9200-10-20	9200-24-35
9200-06-08	9200-12-16	9200-24-38
9200-06-10	9200-12-18	9200-24-42
9200-06-12	9200-12-20	9200-32-40
9200-06-14	9200-12-22	
9200-08-10	9200-12-25	
9200-08-12	9200-16-25	

STEEL INTERNATIONAL ADAPTERS

9210

MALE JIC X FEMALE FLAT-FACE
BSPP (SWIVEL) HIAB

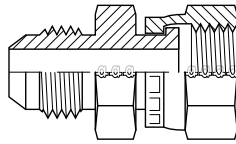

9210-04-04	9210-08-10	9210-12-16
9210-06-04	9210-08-12	9210-16-12
9210-06-06	9210-10-08	9210-16-16
9210-06-08	9210-10-10	
9210-08-06	9210-10-12	
9210-08-08*	9210-12-12	

* Fixed

9220

MALE JIC X SOLID FEMALE JIS

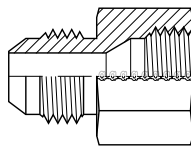

9220-04-02	9220-08-06	9220-16-16
9220-04-04	9220-08-08	9220-20-20
9220-06-04	9220-10-10	9220-24-24
9220-06-06	9220-12-12	9220-32-32

9221

JIS HEX PLUG

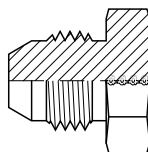

9221-02	9221-10	9221-24
9221-04	9221-12	9221-32
9221-06	9221-16	
9221-08	9221-20	

9222

JIS SWIVEL CAP

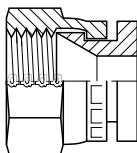

9222-02	9222-10	9222-24
9222-04	9222-12	9222-32
9222-06	9222-16	
9222-08	9222-20	

9223

MALE JIS X MALE BSPT

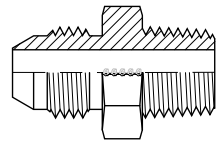

9223-04-04	9223-08-06	9223-16-16
9223-04-06	9223-08-08	9223-20-20
9223-06-04	9223-12-08	9223-24-24
9223-06-06	9223-12-12	9223-32-32

9224

90° MALE JIS X MALE BSPT
ELBOW

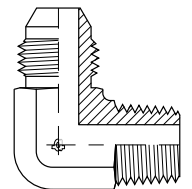

9224-04-02	9224-06-06	9224-12-12
9224-04-04	9224-08-08	9224-16-16

9225

45° MALE JIS X MALE BSPT
ELBOW

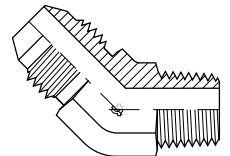

9225-04-04	9225-08-08	9225-16-16
9225-06-06	9225-12-12	

9226

FEMALE JIC X FEMALE JIS
SWIVEL

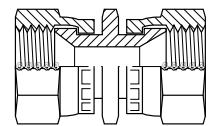

9226-06-06
9226-08-08

9228

MALE JIC X 50° MALE NISSAN
(METRIC THREAD)

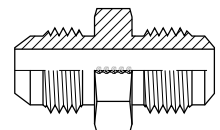

9228-06-16

TUTORIALS

FEATURED

STEEL

STAINLESS STEEL

BRASS

MEALLEABLE IRON

QUICK REFERENCE

ABOUT

STEEL INTERNATIONAL ADAPTERS

TUTORIALS

9229

MALE JIC X 50° FEMALE NISSAN
(METRIC THREAD)

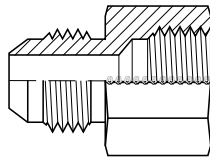

9229-06-16

FEATURED

9230

MALE JIC X FEMALE KOMATSU

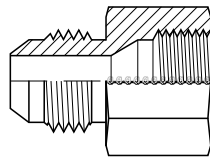

9230-04-12

9230-08-22

9230-04-14

9230-10-24

9230-06-16

9230-12-30

9230-06-18

9230-16-33

STEEL

9231

KOMATSU PLUG

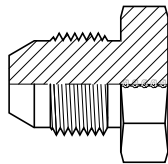

9231-14

9231-24

9231-42

9231-16

9231-30

9231-18

9231-33

9231-22

9231-36

STAINLESS STEEL

BRASS

9232

KOMATSU SWIVEL CAP

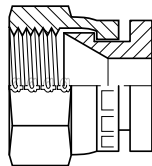

9232-14

9232-24

9232-16

9232-30

9232-18

9232-33

9232-22

9232-42

MEALLEABLE IRON QUICK REFERENCE

9233

MALE KOMATSU X MALE BSPT

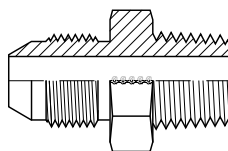

9233-14-02

9233-16-04

ABOUT

9234

MALE METRIC X FEMALE BSPT

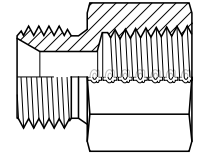

9234-08X1.0-02

9235

MALE METRIC X FEMALE NPT

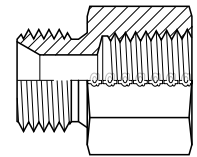

9235-04X.70-02

9235-20-04

9235-06X.75-02

9235-20-06

9235-06X.75-04

9235-20-08

9235-06X1.0-02

9235-22-04

9235-08X1.0-02

9235-22-06

9235-08X1.25-02

9235-22-08

9235-10-02

9235-22-12

9235-10-04

9235-24-12

9235-10-06

9235-26-04

9235-10X1.25-02

9235-26-08

9235-10X1.5-02

9235-26-12

9235-10X1.5-04

9235-27X1.5-12

9235-12-02

9235-27-12

9235-12-04

9235-30X1.5-06

9235-12-06

9235-30X1.5-08

9235-12X1.0-02

9235-30X1.5-12

9235-12X1.0-04

9235-30-12

9235-12X1.25-04

9235-33X1.5-08

9235-14-04

9235-33-16

9235-14-06

9235-36-16

9235-16-04

9235-40-24

9235-16-06

9235-42-16

9235-16-08

9235-42-20

9235-18-04

9235-42X1.5-24

9235-18-06

9235-48-24

9235-18-08

STEEL INTERNATIONAL ADAPTERS

9236

MALE KOMATSU X MALE
KOMATSU

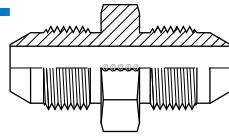

9236-14-14
9236-18-18

9236-22-22
9236-24-24

9236-30-30
9236-33-33

9237

MALE JIC X MALE KOMATSU

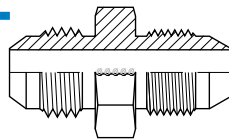

9237-04-14
9237-06-16
9237-06-18
9237-08-22

9237-10-24
9237-12-30
9237-16-33

9240

MALE JIC X FEMALE BSPP
(SWIVEL)

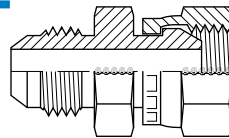

9240-04-02
9240-04-04
9240-04-06
9240-04-08
9240-05-04
9240-05-06
9240-05-08
9240-06-04
9240-06-06
9240-06-08

9240-08-06
9240-08-08
9240-08-10
9240-08-12
9240-10-06
9240-10-08
9240-10-10
9240-10-12
9240-12-08
9240-12-12

9240-12-16
9240-14-12
9240-16-12
9240-16-16
9240-20-20
9240-24-24
9240-32-32

9245

MALE JIC X MALE JSW
TUBE END

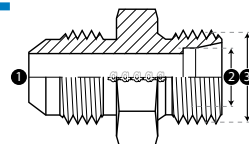

9245-12-25-34
9245-20-38-48

9246

MALE JSW TUBE PLUG

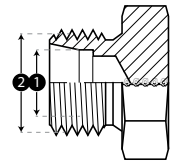

9246-25-34

9247

MALE JIC X MALE KOBELCO

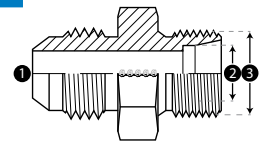

9247-12-22-30
9247-12-28-36

9247-16-22-30
9247-16-28-36

9247-16-35-45
9247-20-35-45

9248

KOBELCO TUBE PLUG

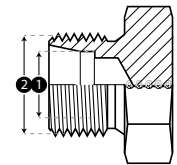

9248-22-30
9248-28-36

9248-35-45

9249

KOBELCO (SWIVEL) CAP

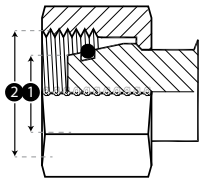

9249-22-30
9249-28-36

9249-35-45

9250

90° MALE JIC X FEMALE BSPP
SWIVEL ELBOW

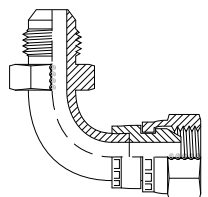

9250-04-04
9250-06-06

9250-08-08
9250-10-10

9250-12-12
9250-16-16

STEEL INTERNATIONAL ADAPTERS

TUTORIALS

FEATURED

STEEL

STAINLESS STEEL

BRASS

MEALLEABLE IRON

QUICK REFERENCE

ABOUT

9259

90° MALE JIS X MALE BSPP ADJ. ELBOW

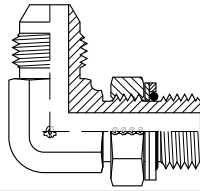

9259-06-06
9259-08-08

9292

90° MALE JIS X FEMALE JIS (SWIVEL) ELBOW

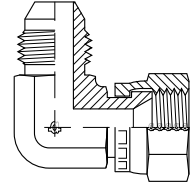

9292-04-04 9292-08-08
9292-06-06 9292-12-12

9260

45° MALE JIC X FEMALE BSPP SWIVEL ELBOW

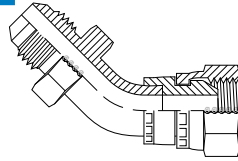

9260-04-04 9260-08-08 9260-16-16
9260-06-06 9260-12-12

9293TP

JIS TEST PORT TEE (SWIVEL)

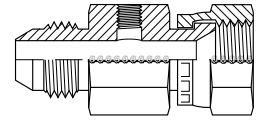

9293TP-04-04 9293TP-08-08
9293TP-06-06

* Test Port = Female M10x1.0

9277

MALE JIS X MALE SAE ORB

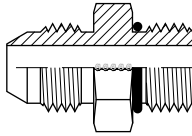

9277-04-06 9277-06-04 9277-08-06
9277-04-08 9277-06-06

9294

45° MALE JIS X FEMALE JIS SWIVEL ELBOW

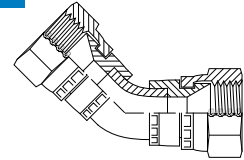

9294-04-04 9294-08-08
9294-06-06

9278

90° MALE JIS X MALE SAE ORB ADJ. ELBOW

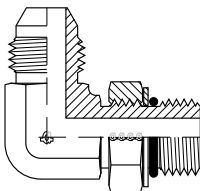

9278-04-04
9278-08-06

9325

MALE NPT X FEMALE METRIC (SOLID)

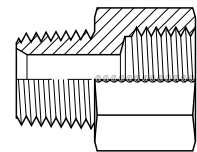

9325-02-06X1.0	9325-04-16X1.5	9325-12-20X1.5
9325-02-08X1.0	9325-06-14X1.5	9325-12-26X1.5
9325-02-10X1.0	9325-06-16X1.5	9325-12-30X1.5
9325-02-10X1.25	9325-06-18X1.5	9325-12-30X2.0
9325-02-10X1.5	9325-08-14X1.5	9325-16-26X1.5
9325-02-12X1.0	9325-08-18X1.5	9325-20-30X1.5
9325-02-12X1.5	9325-08-20X1.5	
9325-04-10X1.0	9325-08-22X1.5	
9325-04-12X1.5	9325-08-24X1.5	
9325-04-14X1.5	9325-12-18X1.5	

9291

FEMALE JIS RUN TEE

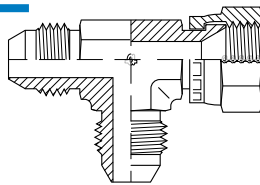

9291-04-04-04 9291-08-08-08
9291-06-06-06 9291-12-12-12

9327

FEMALE KOMATSU X FEMALE KOMATSU (SWIVEL)

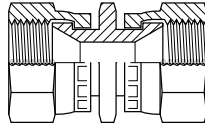

9327-14-14
9327-18-18

9327-22-22
9327-24-24

9327-30-30

9333

30° TO 37° CONVERSION SEAT CONVERTS KOMATSU FEMALE TO GB 74 (CHINESE)

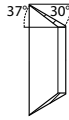

COMING 2020!

9333-12MM
9333-14MM
9333-16MM
9333-18MM

9333-22MM
9333-24MM
9333-30MM

9333FF

GB FACE SEAL CONVERSION SEAT FOR FEMALE KOMATSU

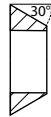

COMING 2020!

9333FF-12MM
9333FF-14MM
9333FF-16MM
9333FF-18MM

9333FF-22MM
9333FF-24MM
9333FF-30MM

9335

MALE METRIC X FEMALE SAE ORB

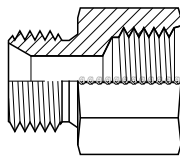

9335-08X1.0-04
9335-12X1.0-04
9335-14-06
9335-16-06

9335-18-08
9335-22-06
9335-22-10
9335-26-12

9335-27-12
9335-33-16

9336

MALE JIS X MALE JIS

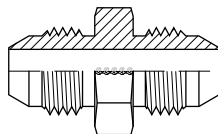

9336-02-02
9336-04-04
9336-06-06
9336-08-08

9336-12-12
9336-16-16
9336-20-20

9337

MALE JIC X MALE JIS

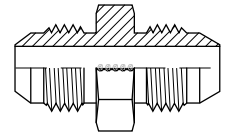

9337-04-02
9337-04-04

9337-06-06
9337-08-08

9337-12-12
9337-16-16

9355

90° FEMALE JIC X FEMALE JIC (SWIVEL) ELBOW

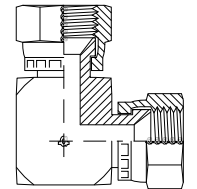

9355-04-04
9355-05-05
9355-06-06
9355-08-08

9355-10-10
9355-12-12
9355-16-16

9391

FEMALE KOMATSU RUN TEE

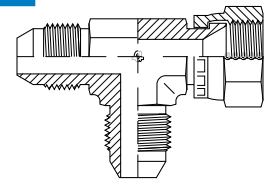

9391-14-14-14
9391-16-16-16
9391-18-18-18
9391-22-22-22

9391-24-24-24
9391-30-30-30
9391-33-33-33

9392

90° MALE KOMATSU X FEMALE KOMATSU (SWIVEL) ELBOW

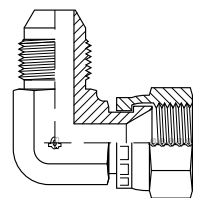

9392-14-14
9392-16-16
9392-18-18
9392-22-22

9392-24-24
9392-30-30
9392-33-33

STEEL INTERNATIONAL ADAPTERS

TUTORIALS

FEATURED

STEEL

STAINLESS STEEL

BRASS

MEALLEABLE IRON

QUICK REFERENCE

ABOUT

9474

BSPP ADJUSTABLE NIPPLE
C/W OR & RR

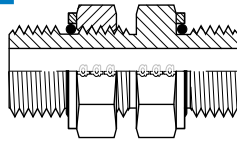

- | | |
|------------|------------|
| 9474-02-02 | 9474-12-12 |
| 9474-04-04 | 9474-16-16 |
| 9474-06-06 | 9474-20-20 |
| 9474-08-08 | 9474-24-24 |

9500

BONDED SEAL FOR BSPP THREAD

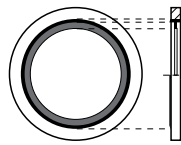

- | | | |
|---------|---------|---------|
| 9500-02 | 9500-10 | 9500-24 |
| 9500-04 | 9500-12 | 9500-32 |
| 9500-06 | 9500-16 | 9500-40 |
| 9500-08 | 9500-20 | 9500-48 |

9500MM

BONDED SEAL FOR METRIC
THREAD

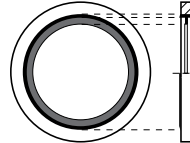

- | | | |
|-----------|-----------|-----------|
| 9500-04MM | 9500-20MM | 9500-42MM |
| 9500-06MM | 9500-22MM | 9500-45MM |
| 9500-08MM | 9500-24MM | 9500-50MM |
| 9500-10MM | 9500-26MM | 9500-52MM |
| 9500-12MM | 9500-27MM | |
| 9500-14MM | 9500-30MM | |
| 9500-16MM | 9500-33MM | |
| 9500-18MM | 9500-36MM | |

9500NSC

BONDED SEAL FOR BSPP THREAD
NON-SELF CENTERING

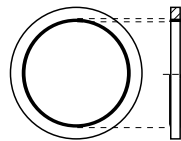

- | | |
|-------------|-------------|
| 9500-002NSC | 9500-008NSC |
| 9500-004NSC | 9500-010NSC |
| 9500-006NSC | 9500-020NSC |

9500MM-NSC

BONDED SEAL FOR METRIC
THREAD NON-SELF CENTERING

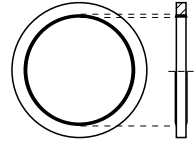

- | | |
|---------------|---------------|
| 9500-010MMNSC | 9500-018MMNSC |
| 9500-012MMNSC | 9500-020MMNSC |
| 9500-014MMNSC | 9500-022MMNSC |

9500V

BONDED VITON SEAL FOR BSPP
THREAD

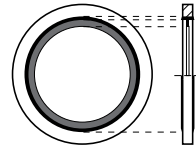

- | | | |
|----------|----------|----------|
| 9500-02V | 9500-10V | 9500-24V |
| 9500-04V | 9500-12V | 9500-32V |
| 9500-06V | 9500-16V | 9500-40V |
| 9500-08V | 9500-20V | 9500-48V |

9500MM-V

BONDED VITON SEAL FOR
METRIC THREAD

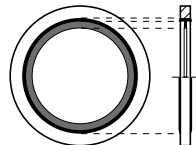

- | | | |
|------------|------------|------------|
| 9500-10MMV | 9500-18MMV | 9500-26MMV |
| 9500-12MMV | 9500-20MMV | |
| 9500-14MMV | 9500-22MMV | |
| 9500-16MMV | 9500-24MMV | |

9536

MALE BSPT X FEMALE SAE ORB

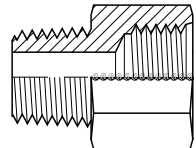

- | | |
|------------|------------|
| 9536-02-04 | 9536-08-10 |
| 9536-04-06 | 9536-12-12 |
| 9536-06-08 | 9536-16-16 |
| 9536-08-08 | |

STEEL INTERNATIONAL ADAPTERS

9555

FEMALE JIC (SWIVEL) TEE

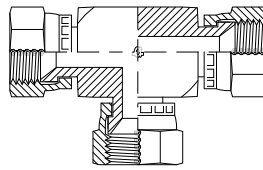

9555-04-04-04	9555-10-10-10
9555-05-05-05	9555-12-12-12
9555-06-06-06	9555-16-16-16
9555-08-08-08	9555-20-20-20

9605

MALE JIC X MALE METRIC DIN (EXTRA LIGHT AND LIGHT DUTY)

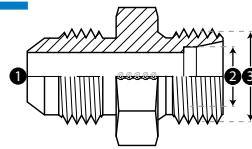

9605-04-06X1.0*	9605-08-L12-18
9605-04-08X1.0*	9605-08-L15-22
9605-04-08X1.25*	9605-10-25X1.5*
9605-04-10X1.25*	9605-10-L12-18
9605-04-10X1.5*	9605-10-L15-22
9605-04-12X1.0*	9605-10-L18-26
9605-04-L06-12	9605-12-25X1.5*
9605-04-L08-14	9605-12-30X1.5*
9605-04-L10-16	9605-12-L15-22
9605-04-LL06-10	9605-12-L18-24X1.5
9605-04-LL08-12	9605-12-L18-26
9605-05-12X1.0*	9605-12-L22-30
9605-05-12X1.25*	9605-12-L22-30X1.5
9605-06-10X1.5*	9605-16-L18-26
9605-06-12X1.25*	9605-16-L22-30X1.5
9605-06-12X1.75	9605-16-L28-36
9605-06-L08-14	9605-20-33X2.0*
9605-06-L10-16	9605-20-50X1.5*
9605-06-L12-18	9605-20-L27-38X1.5
9605-06-L15-22	9605-20-L35-45
9605-06-LL06-10	9605-24-L42-52
9605-06-LL08-12	
9605-08-12X1.25*	
9605-08-L10-16	

* PORT ONLY

9605S

MALE JIC X MALE METRIC DIN (LIGHT DUTY) C/W OR & RR

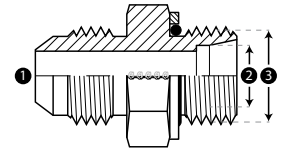

9605S-04-L06-12	9605S-08-L15-22
9605S-04-L08-14	9605S-10-L15-22
9605S-04-LL06-10	9605S-10-L18-26
9605S-04-LL08-12	9605S-12-L15-22
9605S-06-L08-14	9605S-12-L18-26
9605S-06-L10-16	9605S-12-L22-30
9605S-06-L12-18	9605S-16-L28-36
9605S-06-LL08-12	9605S-20-L35-45
9605S-08-L10-16	9605S-24-L42-52
9605S-08-L12-18	

9606

MALE JIC X MALE METRIC DIN (HEAVY DUTY)

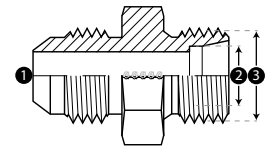

9606-04-S06-14	9606-10-S14-22
9606-04-S08-16	9606-10-S16-24
9606-04-S10-18	9606-12-S16-24
9606-06-S08-16	9606-12-S20-30
9606-06-S10-18	9606-12-S25-36
9606-06-S12-20	9606-16-S20-30
9606-06-S14-22	9606-16-S25-36
9606-08-S10-18	9606-16-S30-42
9606-08-S12-20	9606-20-S30-42
9606-08-S14-22	9606-20-S38-52
9606-08-S16-24	9606-24-S38-52
9606-10-S12-20	

STEEL INTERNATIONAL ADAPTERS

TUTORIALS

FEATURED

STEEL

STAINLESS STEEL

BRASS

MEALLEABLE IRON

QUICK REFERENCE

ABOUT

9606S

MALE JIC X MALE METRIC
DIN (HEAVY DUTY)
C/W OR & RR

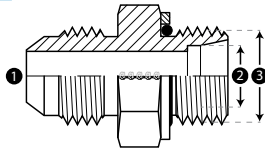

9606S-04-S06-14	9606S-12-S16-24
9606S-04-S08-16	9606S-12-S20-30
9606S-06-S08-16	9606S-12-S25-36
9606S-06-S10-18	9606S-16-S20-30
9606S-06-S12-20	9606S-16-S25-36
9606S-06-S14-22	9606S-16-S30-42
9606S-08-S10-18	9606S-20-S30-42
9606S-08-S12-20	9606S-20-S38-52
9606S-08-S16-24	9606S-24-S38-52
9606S-10-S12-20	
9606S-10-S14-22	
9606S-10-S16-24	

9607

MALE NPT X
MALE DIN METRIC

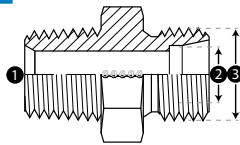

9607-02-12*	9607-08-16*
9607-02-LL06-10	9607-08-L12-18
9607-04-08X1.25*	9607-08-L15-22
9607-04-10X1.0*	9607-08-S12-20
9607-04-12X1.25*	9607-16-30*
9607-04-14*	9607-24-38X1.5*
9607-06-12X1.25*	9607-24-S30-42
9607-06-18*	
9607-06-L12-18	
9607-08-12X1.25*	

* PORT ONLY

9622

MALE JIC X FEMALE METRIC
(SOLID)

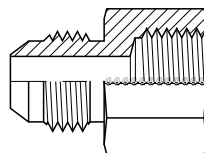

9622-04-06X1.0	9622-04-10X1.0
9622-04-08X1.0	

9624

FEMALE JIC X MALE METRIC
DIN (LIGHT & HEAVY DUTY)

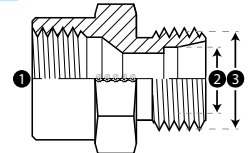

9624-04-L06-12	9624-08-S12-20	9624-20-S30-42
9624-04-S06-14	9624-08-S14-22	9624-24-L35-45
9624-06-L08-14	9624-08-S16-24	9624-24-L42-52
9624-06-L10-16	9624-12-L18-26	9624-24-S38-52
9624-06-S08-16	9624-12-L22-30	
9624-06-S10-18	9624-12-S20-30	
9624-08-L12-18	9624-16-L28-36	
9624-08-L15-22	9624-16-S25-36	

9634TP

KOMATSU TEST PORT TEE

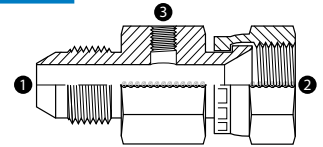

9634TP-14-14-02*	9634TP-22-22-06	9634TP-30-30-06
9634TP-18-18-04	9634TP-24-24-06	9634TP-33-33-08

* TEST PORT IS NPT, ALL OTHERS ARE ORB

9635S

MALE METRIC DIN (LIGHT
DUTY) C/W OR & RR X
FEMALE NPT

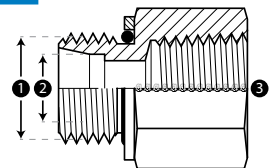

9635S-12-L06-04	9635S-18-L12-06
9635S-12-L06-06	9635S-18-L12-08
9635S-14-L08-04	9635S-22-L15-06
9635S-14-L08-06	9635S-22-L15-08
9635S-16-L10-04	9635S-22-L15-12
9635S-16-L10-06	9635S-26-L18-12
9635S-16-L10-08	9635S-30-L22-12
9635S-18-L12-04	9635S-30X1.5-L22-12

9636S

MALE METRIC DIN (HEAVY DUTY) C/W OR & RR X FEMALE NPT

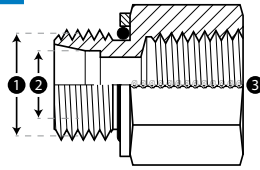

9636S-14-S06-06
9636S-20-S12-04
9636S-24-S16-12
9636S-42-S30-16

9636S-42-S30-20

9638

MALE METRIC X FEMALE METRIC BUSHING

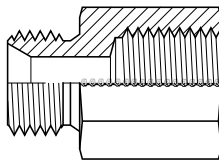

9638-08X1.0-06X1.0
9638-10X1.0-08X1.0
9638-14X1.5-10X1.0
9638-16X1.5-12X1.5
9638-16X1.5-22X1.5
9638-18X1.5-10X1.0
9638-18X1.5-14X1.5
9638-18X1.5-16X1.5
9638-18X1.5-27X2.0
9638-20X1.5-16X1.5

9638-22X1.5-14X1.5
9638-22X1.5-18X1.5
9638-24X1.5-20X1.5
9638-26X1.5-22X1.5
9638-27X2.0-18X1.5
9638-30X2.0-26X1.5
9638-33X2.0-14X1.5
9638-36X2.0-30X2.0
9638-42X2.0-14X1.5
9638-48X2.0-42X2.0

9643

FEMALE NPT X FEMALE METRIC (SOLID)

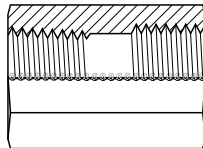

9643-02-06X1.0
9643-02-08X1.0
9643-02-10X1.0
9643-04-12X1.5

9643-04-14X1.5
9643-04-16X1.5

9777

BSPP FLAT FACE CONVERSION ADAPTER HIAB

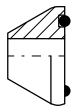

9777-04
9777-06

9777-08
9777-10

9777-12
9777-16

9900

FEMALE BSPP (SWIVEL) X HOSE BARB

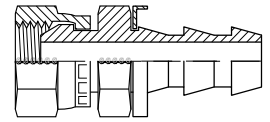

9900-04-04
9900-06-06

9900-08-08
9900-10-10

9900-12-12
9900-16-16

9905

45° FEMALE BSPP (SWIVEL) X HOSE BARB ELBOW

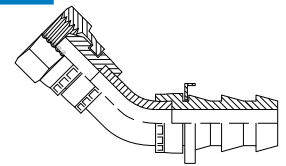

9905-04-04
9905-06-06

9905-08-08
9905-10-10

9905-12-12
9905-16-16

9910

90° FEMALE BSPP (SWIVEL) X HOSE BARB ELBOW

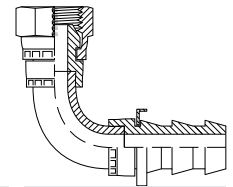

9910-04-04
9910-06-06

9910-08-08
9910-10-10

9910-12-12
9910-16-16

9915

MALE BSPT X HOSE BARB

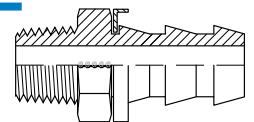

9915-04-04
9915-06-06
9915-06-08
9915-08-06

9915-08-08
9915-12-12
9915-16-16
9915-20-20

STEEL INTERNATIONAL ADAPTERS

TUTORIALS

FEATURED

STEEL

STAINLESS STEEL

BRASS

MEALLEABLE IRON QUICK REFERENCE

ABOUT

9920

MALE BSPP X HOSE BARB

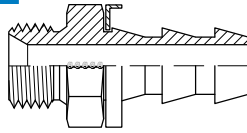

- | | | |
|------------|------------|------------|
| 9920-04-04 | 9920-08-08 | 9920-16-16 |
| 9920-06-06 | 9920-12-12 | |

9921

MALE BSPP X HOSE BARB
(NEEDS CLAMP)

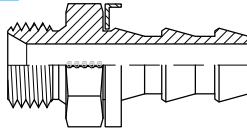

- | | | |
|------------|------------|------------|
| 9921-04-06 | 9921-12-10 | 9921-24-28 |
| 9921-06-08 | 9921-12-16 | 9921-24-32 |
| 9921-08-06 | 9921-16-16 | 9921-32-32 |
| 9921-08-08 | 9921-16-20 | |
| 9921-08-10 | 9921-20-24 | |
| 9921-12-08 | 9921-24-24 | |

9999

BSPP TO JIS CONVERSION SEAT

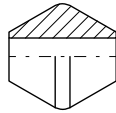

- | | | |
|---------|---------|---------|
| 9999-02 | 9999-10 | 9999-24 |
| 9999-04 | 9999-12 | |
| 9999-06 | 9999-16 | |
| 9999-08 | 9999-20 | |

CWM

COPPER WASHER METRIC

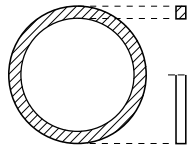

- | | | |
|--------|--------|--------|
| CWM-08 | CWM-16 | CWM-30 |
| CWM-10 | CWM-18 | |
| CWM-12 | CWM-20 | |
| CWM-14 | CWM-22 | |

CWR

COPPER WASHER BSPP

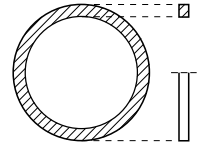

- | | | |
|----------|------------|------------|
| CWR-1/8" | CWR-5/8" | CWR-1-1/2" |
| CWR-1/4" | CWR-3/4" | |
| CWR-3/8" | CWR-1" | |
| CWR-1/2" | CWR-1-1/4" | |

ESB

BSPP ELASTOMERIC SEAL

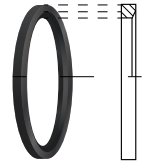

- | | | |
|--------|--------|--------|
| ESB-02 | ESB-10 | ESB-24 |
| ESB-04 | ESB-12 | ESB-32 |
| ESB-06 | ESB-16 | |
| ESB-08 | ESB-20 | |

ESM

METRIC ELASTOMERIC SEAL

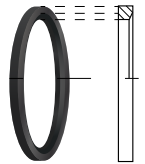

- | | |
|--------|--------|
| ESM-10 | ESM-20 |
| ESM-12 | ESM-22 |
| ESM-16 | |
| ESM-18 | |

OR

O-RING FOR BSPP THREAD



- | | |
|-------|-------|
| OR-02 | OR-12 |
| OR-04 | OR-16 |
| OR-06 | OR-20 |
| OR-08 | OR-24 |

STEEL INTERNATIONAL ADAPTERS

OR-MM

O-RING FOR METRIC THREAD



OR-10MM	OR-18MM	OR-27MM
OR-12MM	OR-20MM	OR-30MM
OR-14MM	OR-22MM	OR-33MM
OR-16MM	OR-26MM	OR-42MM

RR-MM

RETAINING RING METRIC

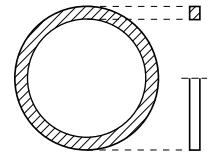

RR-10MM	RR-22MM	RR-42MM
RR-12MM	RR-24MM	RR-48MM
RR-14MM	RR-26MM	
RR-16MM	RR-27MM	
RR-18MM	RR-30MM	
RR-20MM	RR-33MM	

ORFS

O-RING FOR O-RING FACE SEAL



ORFS-04	ORFS-12
ORFS-06	ORFS-16
ORFS-08	ORFS-20
ORFS-10	ORFS-24

SAE ORB O-RING

O-RING FOR SAE ORB THREAD



3-904	3-910	3-924
3-905	3-912	3-932
3-906	3-916	
3-908	3-920	

RR

RETAINING RING BSPP

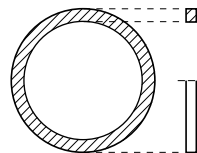

RR-02	RR-12
RR-04	RR-16
RR-06	RR-20
RR-08	RR-24

TUTORIALS

FEATURED

STEEL

STAINLESS STEEL

BRASS

MEALLEABLE IRON

QUICK REFERENCE

ABOUT

STAINLESS STEEL 24° DIN TUBE FITTINGS/ADAPTERS

TUTORIALS

SS5000L

STAINLESS DIN UNION LIGHT DUTY

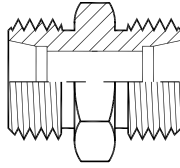

SS5000L-06	SS5000L-15
SS5000L-08	SS5000L-18
SS5000L-10	SS5000L-22
SS5000L-12	SS5000L-28

FEATURED

SS5002L

STAINLESS DIN LIGHT DUTY X MALE BSPP ES SEAL

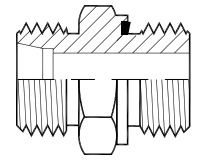

SS5002L-06-02	SS5002L-10-08	SS5002L-18-08
SS5002L-06-04	SS5002L-12-04	SS5002L-18-12
SS5002L-08-02	SS5002L-12-06	SS5002L-22-12
SS5002L-08-04	SS5002L-12-08	SS5002L-28-16
SS5002L-10-04	SS5002L-15-06	SS5002L-35-20
SS5002L-10-06	SS5002L-15-08	

STEEL

SS5000S

STAINLESS DIN UNION HEAVY DUTY

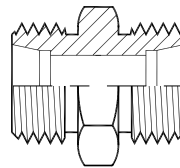

SS5000S-06	SS5000S-14
SS5000S-08	SS5000S-16
SS5000S-10	SS5000S-20
SS5000S-12	SS5000S-25

STAINLESS STEEL

SS5002S

STAINLESS DIN HEAVY DUTY X MALE BSPP ES SEAL

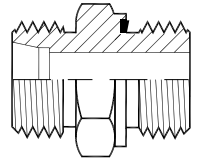

SS5002S-06-04	SS5002S-12-04	SS5002S-16-12
SS5002S-08-04	SS5002S-12-06	SS5002S-20-08
SS5002S-08-06	SS5002S-12-08	SS5002S-20-12
SS5002S-10-04	SS5002S-14-08	SS5002S-25-12
SS5002S-10-06	SS5002S-16-06	SS5002S-25-16
SS5002S-10-08	SS5002S-16-08	SS5002S-30-20

BRASS

SS5001L

STAINLESS DIN LIGHT DUTY X MALE BSPP SHOULDER SEAL (FORM B)

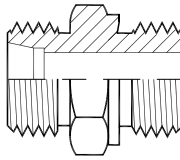

SS5001L-06-02	SS5001L-10-08	SS5001L-18-08
SS5001L-06-04	SS5001L-12-04	SS5001L-18-12
SS5001L-08-02	SS5001L-12-06	SS5001L-22-12
SS5001L-08-04	SS5001L-12-08	SS5001L-28-16
SS5001L-10-04	SS5001L-15-06	
SS5001L-10-06	SS5001L-15-08	

MEALLEABLE IRON

SS5007L

STAINLESS DIN LIGHT DUTY X MALE NPT

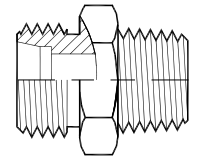

SS5007L-06-02	SS5007L-10-06	SS5007L-15-08
SS5007L-06-04	SS5007L-12-04	SS5007L-18-08
SS5007L-08-04	SS5007L-12-06	SS5007L-22-12
SS5007L-10-04	SS5007L-12-08	SS5007L-28-16

QUICK REFERENCE

SS5001S

STAINLESS DIN HEAVY DUTY X MALE BSPP SHOULDER SEAL (FORM B)

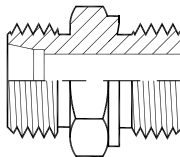

SS5001S-06-04	SS5001S-12-04	SS5001S-16-12
SS5001S-08-04	SS5001S-12-06	SS5001S-20-08
SS5001S-08-06	SS5001S-12-08	SS5001S-20-12
SS5001S-10-04	SS5001S-14-08	SS5001S-25-12
SS5001S-10-06	SS5001S-16-06	SS5001S-25-16
SS5001S-10-08	SS5001S-16-08	

SS5007S

STAINLESS DIN HEAVY DUTY X MALE NPT

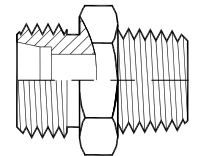

SS5007S-06-04	SS5007S-12-04	SS5007S-16-08
SS5007S-08-04	SS5007S-12-06	SS5007S-20-12
SS5007S-10-04	SS5007S-12-08	SS5007S-25-16
SS5007S-10-06	SS5007S-14-08	SS5007S-30-20

ABOUT

STAINLESS STEEL 24° DIN TUBE FITTINGS/ADAPTERS

SS5040L

STAINLESS DIN BULKHEAD UNION LIGHT DUTY

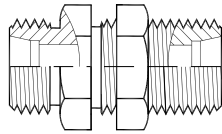

SS5040L-06	SS5040L-15
SS5040L-08	SS5040L-18
SS5040L-10	SS5040L-22
SS5040L-12	SS5040L-28

SS5040S

STAINLESS DIN BULKHEAD UNION HEAVY DUTY

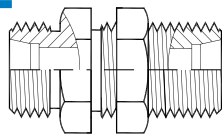

SS5040S-06	SS5040S-14
SS5040S-08	SS5040S-16
SS5040S-10	SS5040S-20
SS5040S-12	SS5040S-25

SS5042L

STAINLESS 90° DIN LIGHT DUTY BULKHEAD UNION

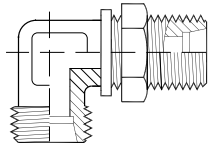

SS5042L-06	SS5042L-15
SS5042L-08	SS5042L-18
SS5042L-10	SS5042L-22
SS5042L-12	SS5042L-28

SS5042S

STAINLESS 90° DIN HEAVY DUTY BULKHEAD UNION

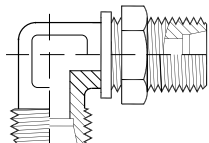

SS5042S-06	SS5042S-14
SS5042S-08	SS5042S-16
SS5042S-10	SS5042S-20
SS5042S-12	SS5042S-25

SS5055L

STAINLESS 90° DIN UNION LIGHT DUTY ELBOW

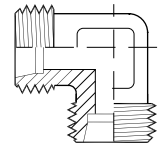

SS5055L-06	SS5055L-15
SS5055L-08	SS5055L-18
SS5055L-10	SS5055L-22
SS5055L-12	SS5055L-28

5055S

STAINLESS 90° DIN UNION HEAVY DUTY ELBOW

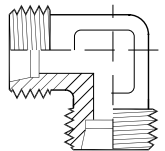

SS5055S-06	SS5055S-14
SS5055S-08	SS5055S-16
SS5055S-10	SS5055S-20
SS5055S-12	SS5055S-25

SS5059L

STAINLESS 90° DIN LIGHT DUTY X MALE BSPP ADJUSTABLE ELBOW

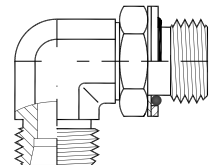

SS5059L-06-02	SS5059L-15-08
SS5059L-08-04	SS5059L-18-08
SS5059L-10-04	SS5059L-22-12
SS5059L-12-06	SS5059L-28-16

SS5059S

STAINLESS 90° DIN HEAVY DUTY X MALE BSPP ADJUSTABLE ELBOW

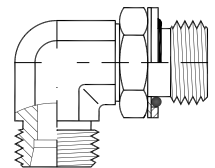

SS5059S-06-04	SS5059S-16-08
SS5059S-08-04	SS5059S-20-12
SS5059S-10-06	SS5059S-25-16
SS5059S-12-06	

To order with nut(s) and cutting ring(s) add a "C" to the end of the part number.

STAINLESS STEEL 24° DIN TUBE FITTINGS/ADAPTERS

TUTORIALS

SS5068L

STAINLESS DIN LIGHT DUTY X
MALE METRIC ES SEAL

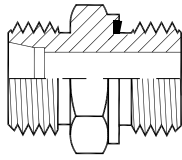

SS5068L-06-10	SS5068L-12-18	SS5068L-22-26
SS5068L-08-12	SS5068L-12-22	SS5068L-28-33
SS5068L-10-14	SS5068L-15-18	
SS5068L-10-18	SS5068L-15-22	
SS5068L-10-22	SS5068L-18-18	
SS5068L-12-16	SS5068L-18-22	

FEATURED

STEEL

SS5068S

STAINLESS DIN HEAVY DUTY X
MALE METRIC ES SEAL

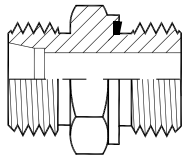

SS5068S-06-12	SS5068S-14-20
SS5068S-08-14	SS5068S-16-22
SS5068S-10-16	SS5068S-20-27
SS5068S-12-18	SS5068S-25-33

STAINLESS STEEL

BRASS

SS5080L

STAINLESS DIN UNION TEE
LIGHT DUTY

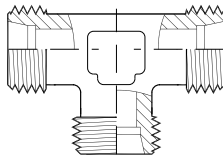

SS5080L-06	SS5080L-15
SS5080L-08	SS5080L-18
SS5080L-10	SS5080L-22
SS5080L-12	SS5080L-28

MEALLEABLE IRON

SS5080S

STAINLESS DIN UNION TEE
HEAVY DUTY

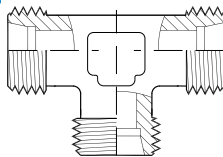

SS5080S-06	SS5080S-14	SS5080S-30
SS5080S-08	SS5080S-16	
SS5080S-10	SS5080S-20	
SS5080S-12	SS5080S-25	

QUICK REFERENCE

ABOUT

SS5201L

STAINLESS DIN LIGHT DUTY
TUBE NUT

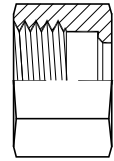

SS5201L-06	SS5201L-15	SS5201L-35
SS5201L-08	SS5201L-18	SS5201L-42
SS5201L-10	SS5201L-22	
SS5201L-12	SS5201L-28	

SS5201S

STAINLESS DIN HEAVY DUTY
TUBE NUT

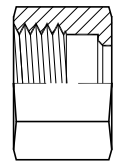

SS5201S-06	SS5201S-14	SS5201S-30
SS5201S-08	SS5201S-16	SS5201S-38
SS5201S-10	SS5201S-20	
SS5201S-12	SS5201S-25	

SS5202

STAINLESS DIN 2353 CUTTING
RING

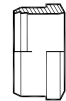

SS5202-06	SS5202-16	SS5202-30
SS5202-08	SS5202-18	SS5202-35
SS5202-10	SS5202-20	SS5202-38
SS5202-12	SS5202-22	SS5202-42
SS5202-14	SS5202-25	
SS5202-15	SS5202-28	

SS5203L

STAINLESS DIN LIGHT DUTY
TUBE PLUG

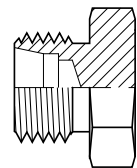

SS5203L-06	SS5203L-15	SS5203L-35
SS5203L-08	SS5203L-18	SS5203L-42
SS5203L-10	SS5203L-22	
SS5203L-12	SS5203L-28	

STAINLESS STEEL 24° DIN TUBE FITTINGS/ADAPTERS

SS5203S

STAINLESS DIN HEAVY DUTY
TUBE PLUG

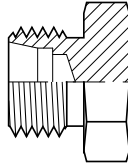

SS5203S-06	SS5203S-14
SS5203S-08	SS5203S-16
SS5203S-10	SS5203S-20
SS5203S-12	SS5203S-25

SS5204L

STAINLESS DIN LIGHT DUTY
TUBE CAP

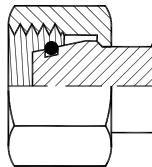

SS5204L-06	SS5204L-15	SS5204L-35
SS5204L-08	SS5204L-18	
SS5204L-10	SS5204L-22	
SS5204L-12	SS5204L-28	

SS5204S

STAINLESS DIN HEAVY DUTY
TUBE CAP

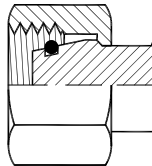

SS5204S-06	SS5204S-14	SS5204S-30
SS5204S-08	SS5204S-16	SS5204S-38
SS5204S-10	SS5204S-20	
SS5204S-12	SS5204S-25	

SS5204P

STAINLESS DIN BLANKING PLUG
(REQUIRES SS5201 TUBE
NUT TO FORM A CAP)

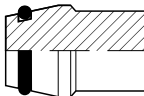

SS5204P-06	SS5204P-16	SS5204P-30
SS5204P-08	SS5204P-18	SS5204P-35
SS5204P-10	SS5204P-20	SS5204P-38
SS5204P-12	SS5204P-22	
SS5204P-14	SS5204P-25	
SS5204P-15	SS5204P-28	

SS5300L

STAINLESS FEMALE DIN LIGHT
DUTY SOFT SEAL UNION

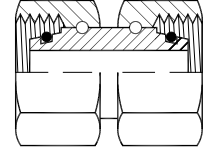

SS5300L-06	SS5300L-15
SS5300L-08	SS5300L-18
SS5300L-10	SS5300L-22
SS5300L-12	SS5300L-28

SS5300S

STAINLESS FEMALE DIN HEAVY
DUTY SOFT SEAL UNION

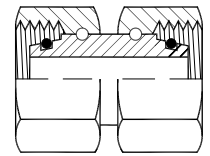

SS5300S-06	SS5300S-14
SS5300S-08	SS5300S-16
SS5300S-10	SS5300S-20
SS5300S-12	SS5300S-25

SS5315L

STAINLESS FEMALE DIN X MALE
DIN REDUCER LIGHT DUTY

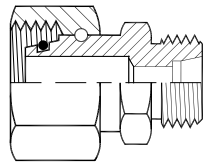

SS5315L-10-06	SS5315L-15-12	SS5315L-22-18
SS5315L-10-08	SS5315L-18-10	SS5315L-28-18
SS5315L-12-06	SS5315L-18-12	SS5315L-28-22
SS5315L-12-08	SS5315L-18-15	
SS5315L-12-10	SS5315L-22-12	
SS5315L-15-10	SS5315L-22-15	

SS5315S

STAINLESS FEMALE DIN X MALE
DIN REDUCER HEAVY DUTY

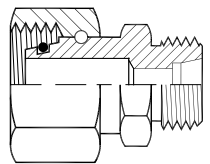

SS5315S-08-06	SS5315S-14-12	SS5315S-25-20
SS5315S-10-06	SS5315S-16-10	
SS5315S-10-08	SS5315S-16-12	
SS5315S-12-08	SS5315S-16-14	
SS5315S-12-10	SS5315S-20-12	
SS5315S-14-10	SS5315S-20-16	

To order with nut(s) and cutting ring(s) add a "C" to the end of the part number.

STAINLESS STEEL 24° DIN TUBE FITTINGS/ADAPTERS

TUTORIALS

SS5360L

STAINLESS 90° DIN LIGHT DUTY X FEMALE DIN SWIVEL

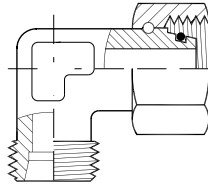

- | | |
|------------|------------|
| SS5360L-06 | SS5360L-15 |
| SS5360L-08 | SS5360L-18 |
| SS5360L-10 | SS5360L-22 |
| SS5360L-12 | SS5360L-28 |

FEATURED

SS5390L

STAINLESS FEMALE DIN LIGHT DUTY SWIVEL RUN TEE

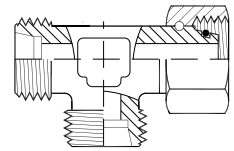

- | | |
|------------|------------|
| SS5390L-06 | SS5390L-15 |
| SS5390L-08 | SS5390L-18 |
| SS5390L-10 | SS5390L-22 |
| SS5390L-12 | SS5390L-28 |

STEEL

SS5360S

STAINLESS 90° DIN HEAVY DUTY X FEMALE DIN SWIVEL

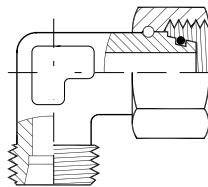

- | | |
|------------|------------|
| SS5360S-06 | SS5360S-14 |
| SS5360S-08 | SS5360S-16 |
| SS5360S-10 | SS5360S-20 |
| SS5360S-12 | SS5360S-25 |

STAINLESS STEEL

SS5390S

STAINLESS FEMALE DIN HEAVY DUTY SWIVEL RUN TEE

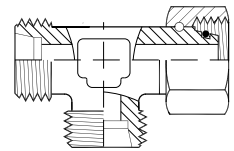

- | | |
|------------|------------|
| SS5390S-06 | SS5390S-14 |
| SS5390S-08 | SS5390S-16 |
| SS5390S-10 | SS5390S-20 |
| SS5390S-12 | SS5390S-25 |

SS5387L

STAINLESS FEMALE DIN LIGHT DUTY SWIVEL BRANCH TEE

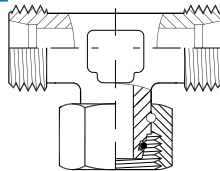

- | | |
|------------|------------|
| SS5387L-06 | SS5387L-15 |
| SS5387L-08 | SS5387L-18 |
| SS5387L-10 | SS5387L-22 |
| SS5387L-12 | SS5387L-28 |

BRASS

5387S

STAINLESS FEMALE DIN HEAVY DUTY SWIVEL BRANCH TEE

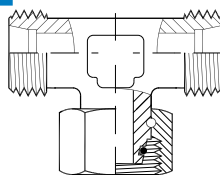

- | | |
|------------|------------|
| SS5387S-06 | SS5387S-14 |
| SS5387S-08 | SS5387S-16 |
| SS5387S-10 | SS5387S-20 |
| SS5387S-12 | SS5387S-25 |

MEALLEABLE IRON QUICK REFERENCE

ABOUT

To order with nut(s) and cutting ring(s) add a "C" to the end of the part number.

STAINLESS STEEL INTERNATIONAL ADAPTERS

SS9000

STAINLESS MALE BSPP NIPPLE

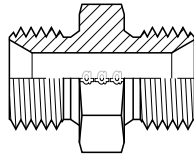

SS9000-02-02	SS9000-08-08	SS9000-20-20
SS9000-04-02	SS9000-10-08	SS9000-24-20
SS9000-04-04	SS9000-12-08	SS9000-24-24
SS9000-06-02	SS9000-12-10	SS9000-32-24
SS9000-06-04	SS9000-12-12	SS9000-32-32
SS9000-06-06	SS9000-16-12	SS9000-48-48
SS9000-08-04	SS9000-16-16	
SS9000-08-06	SS9000-20-16	

SS9002

STAINLESS MALE JIC X MALE BSPP C/W OR & RR

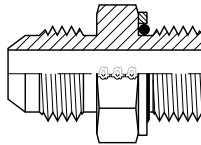

SS9002-04-02	SS9002-08-06	SS9002-16-16
SS9002-04-04	SS9002-08-08	SS9002-16-20
SS9002-04-06	SS9002-08-12	SS9002-20-20
SS9002-06-02	SS9002-10-10	SS9002-24-20
SS9002-06-04	SS9002-12-08	SS9002-24-24
SS9002-06-06	SS9002-12-12	SS9002-32-32
SS9002-06-08	SS9002-12-16	
SS9002-08-04	SS9002-16-12	

SS9003

STAINLESS MALE BSPP X MALE BSPT

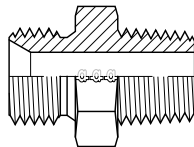

SS9003-02-02	SS9003-08-06	SS9003-20-20
SS9003-02-04	SS9003-08-08	SS9003-24-24
SS9003-04-02	SS9003-08-12	SS9003-32-32
SS9003-04-04	SS9003-10-08	
SS9003-04-06	SS9003-12-12	
SS9003-06-04	SS9003-12-16	
SS9003-06-06	SS9003-16-12	
SS9003-06-08	SS9003-16-16	

SS9005

STAINLESS MALE JIC X MALE BSPP

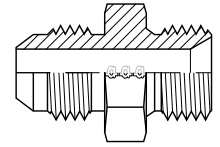

SS9005-04-02	SS9005-08-08	SS9005-16-16
SS9005-04-04	SS9005-08-12	SS9005-20-20
SS9005-06-04	SS9005-10-10	SS9005-24-24
SS9005-06-06	SS9005-12-08	SS9005-32-32
SS9005-06-08	SS9005-12-12	
SS9005-08-06	SS9005-16-12	

SS9006

STAINLESS MALE SAE ORB X MALE BSPP

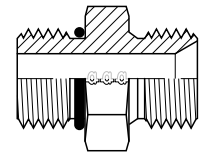

SS9006-04-04	SS9006-08-08	SS9006-20-20
SS9006-04-06	SS9006-08-12	
SS9006-06-04	SS9006-10-08	
SS9006-06-06	SS9006-12-08	
SS9006-06-08	SS9006-12-12	
SS9006-08-06	SS9006-16-16	

SS9007

STAINLESS MALE BSPP X MALE NPT

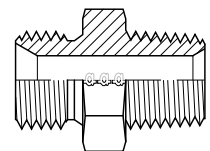

SS9007-02-02	SS9007-08-06	SS9007-16-12
SS9007-02-04	SS9007-08-08	SS9007-16-16
SS9007-04-02	SS9007-08-12	SS9007-20-20
SS9007-04-04	SS9007-10-08	SS9007-24-24
SS9007-04-06	SS9007-12-08	SS9007-32-32
SS9007-06-04	SS9007-12-12	
SS9007-06-06	SS9007-12-16	
SS9007-06-08	SS9007-16-08	

TUTORIALS

FEATURED

STEEL

STAINLESS STEEL

BRASS

MEALLEABLE IRON

QUICK REFERENCE

ABOUT

STAINLESS STEEL INTERNATIONAL ADAPTERS

TUTORIALS

FEATURED

STEEL

STAINLESS STEEL

BRASS

MEALLEABLE IRON QUICK REFERENCE

ABOUT

SS9008

STAINLESS MALE BSPT X MALE NPT

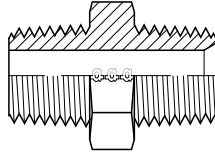

- | | | |
|--------------|--------------|--------------|
| SS9008-04-04 | SS9008-08-08 | SS9008-16-16 |
| SS9008-06-06 | SS9008-12-12 | SS9008-20-20 |

SS9009

STAINLESS MALE JIC X FEMALE BSP

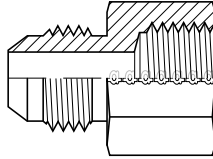

- | | | |
|--------------|--------------|--------------|
| SS9009-04-04 | SS9009-08-06 | SS9009-16-16 |
| SS9009-06-04 | SS9009-08-08 | SS9009-20-20 |
| SS9009-06-06 | SS9009-10-10 | SS9009-24-24 |
| SS9009-06-08 | SS9009-12-12 | |

SS9010

STAINLESS MALE BSPT NIPPLE

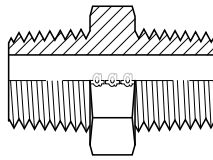

- | | | |
|--------------|--------------|--------------|
| SS9010-02-02 | SS9010-08-08 | SS9010-24-24 |
| SS9010-04-02 | SS9010-12-08 | SS9010-32-32 |
| SS9010-04-04 | SS9010-12-12 | SS9010-40-40 |
| SS9010-06-04 | SS9010-16-12 | SS9010-48-48 |
| SS9010-06-06 | SS9010-16-16 | |
| SS9010-08-06 | SS9010-20-20 | |

SS9011

STAINLESS MALE JIC X MALE BSPT

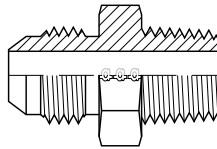

- | | | |
|--------------|--------------|--------------|
| SS9011-04-02 | SS9011-08-08 | SS9011-16-20 |
| SS9011-04-04 | SS9011-08-12 | SS9011-20-20 |
| SS9011-06-04 | SS9011-10-08 | SS9011-24-24 |
| SS9011-06-06 | SS9011-12-08 | |
| SS9011-06-08 | SS9011-12-12 | |
| SS9011-08-06 | SS9011-16-16 | |

SS9015

STAINLESS MALE BSPP X FEMALE BSPP SWIVEL

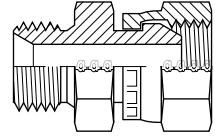

- | | | |
|--------------|--------------|--------------|
| SS9015-02-02 | SS9015-08-04 | SS9015-16-16 |
| SS9015-02-04 | SS9015-08-06 | SS9015-20-20 |
| SS9015-04-02 | SS9015-08-08 | SS9015-24-24 |
| SS9015-04-04 | SS9015-08-12 | SS9015-32-32 |
| SS9015-04-06 | SS9015-10-08 | |
| SS9015-06-04 | SS9015-10-10 | |
| SS9015-06-06 | SS9015-12-08 | |
| SS9015-06-08 | SS9015-12-12 | |

SS9020

STAINLESS MALE JIC X FEMALE JIC SWIVEL

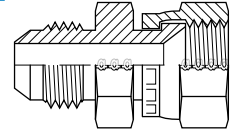

- | | | |
|--------------|--------------|--------------|
| SS9020-04-04 | SS9020-08-08 | SS9020-12-10 |
| SS9020-04-06 | SS9020-08-10 | SS9020-12-12 |
| SS9020-06-04 | SS9020-08-12 | SS9020-16-12 |
| SS9020-06-06 | SS9020-10-08 | SS9020-16-16 |
| SS9020-06-08 | SS9020-10-10 | |
| SS9020-08-06 | SS9020-12-08 | |

SS9021

STAINLESS MALE BSPP X FEMALE JIC SWIVEL

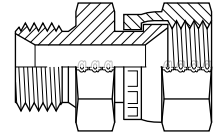

- | | |
|--------------|--------------|
| SS9021-04-04 | SS9021-12-12 |
| SS9021-06-06 | SS9021-16-16 |
| SS9021-08-08 | SS9021-20-20 |
| SS9021-10-10 | SS9021-24-24 |

SS9026

STAINLESS FEMALE JIC X FEMALE JIC (SWIVEL)



- | | |
|--------------|--------------|
| SS9026-04-04 | SS9026-12-12 |
| SS9026-06-06 | SS9026-16-16 |
| SS9026-08-08 | SS9026-20-20 |
| SS9026-10-10 | SS9026-24-24 |

STAINLESS STEEL INTERNATIONAL ADAPTERS

SS9028

STAINLESS BSPP COUNTERSUNK SEALED PLUG

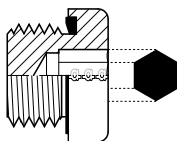

SS9028-02	SS9028-12
SS9028-04	SS9028-16
SS9028-06	SS9028-20
SS9028-08	

SS9029

STAINLESS METRIC COUNTERSUNK SEALED PLUG

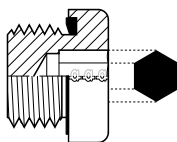

SS9029-10X1.0	SS9029-18X1.5	SS9029-27X2.0
SS9029-12X1.5	SS9029-20X1.5	SS9029-33X2.0
SS9029-14X1.5	SS9029-22X1.5	
SS9029-16X1.5	SS9029-26X1.5	

SS9030

STAINLESS MALE BSPP HEX PLUG

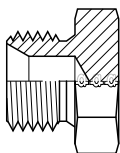

SS9030-02	SS9030-10	SS9030-24
SS9030-04	SS9030-12	SS9030-32
SS9030-06	SS9030-16	
SS9030-08	SS9030-20	

SS9030T

STAINLESS BSPT HEX PLUG

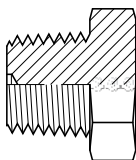

SS9030T-02	SS9030T-12	SS9030T-32
SS9030T-04	SS9030T-16	SS9030T-40
SS9030T-06	SS9030T-20	SS9030T-48
SS9030T-08	SS9030T-24	

SS9033

STAINLESS BSPP SWIVEL CAP

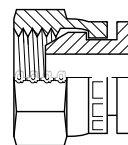

SS9033-02	SS9033-12	SS9033-32
SS9033-04	SS9033-16	
SS9033-06	SS9033-20	
SS9033-08	SS9033-24	

SS9035S

STAINLESS MALE BSPP X FEMALE NPT C/W OR & RR

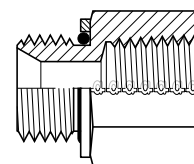

SS9035S-02-02	SS9035S-06-06	SS9035S-16-16
SS9035S-04-02	SS9035S-08-06	SS9035S-20-20
SS9035S-04-04	SS9035S-08-08	SS9035S-24-24
SS9035S-06-04	SS9035S-12-12	SS9035S-32-32

SS9037

STAINLESS MALE NPT X FEMALE BSP

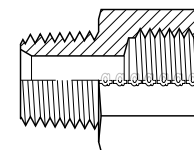

SS9037-02-02	SS9037-06-06	SS9037-20-20
SS9037-02-04	SS9037-08-08	SS9037-24-24
SS9037-04-02	SS9037-12-12	SS9037-32-32
SS9037-04-04	SS9037-16-16	

SS9038

STAINLESS MALE BSPP X FEMALE BSP BUSHING

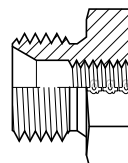

SS9038-06-02	SS9038-12-06	SS9038-32-20
SS9038-08-04	SS9038-16-08	

TUTORIALS

FEATURED

STEEL

STAINLESS STEEL

BRASS

MEALLEABLE IRON QUICK REFERENCE

ABOUT

STAINLESS STEEL INTERNATIONAL ADAPTERS

TUTORIALS

SS9039

STAINLESS MALE BSPP X FEMALE BSP EXTENDED BUSHING

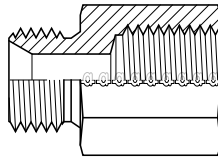

SS9039-02-06	SS9039-06-04	SS9039-08-08
SS9039-04-02	SS9039-06-06	SS9039-12-08
SS9039-04-04	SS9039-06-08	SS9039-12-12
SS9039-04-06	SS9039-08-06	SS9039-16-12

FEATURED

SS9043

STAINLESS FEMALE BSP X FEMALE BSP (SOLID)

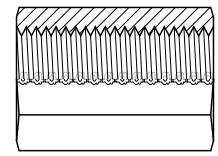

SS9043-02-02	SS9043-12-12	SS9043-32-32
SS9043-04-04	SS9043-16-16	
SS9043-06-06	SS9043-20-20	
SS9043-08-08	SS9043-24-24	

STEEL

SS9040

STAINLESS MALE BSPP X MALE BSPP BULKHEAD

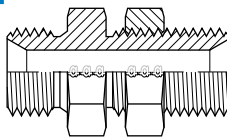

SS9040-02-02	SS9040-10-10	SS9040-24-24
SS9040-04-04	SS9040-12-12	SS9040-32-32
SS9040-06-06	SS9040-16-16	SS9040-40-40
SS9040-08-08	SS9040-20-20	

STAINLESS STEEL

SS9056

STAINLESS 90° MALE JIC X FEMALE BSPP (SWIVEL) ELBOW

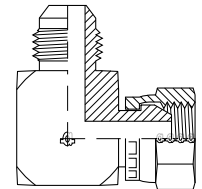

SS9056-04-04	SS9056-08-08	SS9056-16-16
SS9056-06-06	SS9056-12-12	

SS9041

STAINLESS BSPP BULKHEAD LOCKNUT

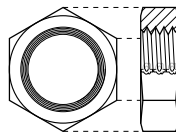

SS9041-02	SS9041-16	SS9041-40
SS9041-04	SS9041-20	
SS9041-08	SS9041-24	
SS9041-12	SS9041-32	

BRASS

SS9058

STAINLESS 45° MALE JIC X MALE BSPP ADJ. ELBOW

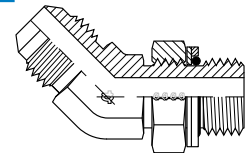

SS9058-04-04	SS9058-08-08	SS9058-16-16
SS9058-06-06	SS9058-12-12	

MEALLEABLE IRON

SS9042

STAINLESS MALE BSPT X FEMALE NPT

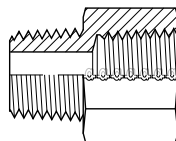

SS9042-02-02	SS9042-12-12
SS9042-04-04	SS9042-16-16
SS9042-06-06	SS9042-20-20
SS9042-08-08	SS9042-24-24

QUICK REFERENCE

SS9059

STAINLESS 90° MALE JIC X MALE BSPP ADJ. ELBOW

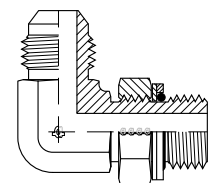

SS9059-04-02	SS9059-06-08	SS9059-12-12
SS9059-04-04	SS9059-08-06	SS9059-16-16
SS9059-06-04	SS9059-08-08	SS9059-20-20
SS9059-06-06	SS9059-12-08	SS9059-24-24

ABOUT

STAINLESS STEEL INTERNATIONAL ADAPTERS

SS9063

STAINLESS 90° MALE JIC X
MALE BSPT ELBOW

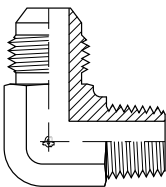

SS9063-04-02	SS9063-08-06
SS9063-04-04	SS9063-08-08
SS9063-06-04	SS9063-10-08
SS9063-06-06	SS9063-12-12

SS9069

STAINLESS 90° MALE JIC X
MALE METRIC ADJ. ELBOW

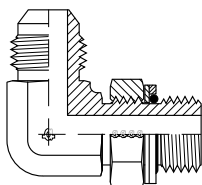

SS9069-04-10	SS9069-06-14	SS9069-08-18
SS9069-04-12	SS9069-06-16	

SS9200

STAINLESS MALE JIC X
DIN STANDPIPE

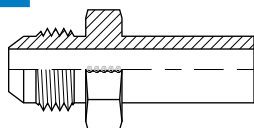

SS9200-04-06	SS9200-08-12	SS9200-12-22
SS9200-04-08	SS9200-08-14	SS9200-12-25
SS9200-04-10	SS9200-08-15	SS9200-16-28
SS9200-06-08	SS9200-08-16	SS9200-16-30
SS9200-06-10	SS9200-12-18	
SS9200-06-12	SS9200-12-20	

SS9235

STAINLESS MALE METRIC X
FEMALE NPT

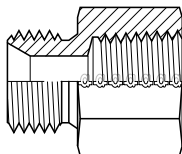

SS9235-10-02	SS9235-18-06
SS9235-10X1.5-02	SS9235-18-08
SS9235-12-04	SS9235-20-08
SS9235-14-04	SS9235-22-08
SS9235-16-06	SS9235-24-12
SS9235-16-08	

SS9240

STAINLESS MALE JIC X FEMALE
BSPP (SWIVEL)

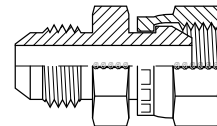

SS9240-04-04	SS9240-08-08	SS9240-16-16
SS9240-06-06	SS9240-12-12	

SS9500

STAINLESS BONDED SEAL FOR
BSPP THREAD

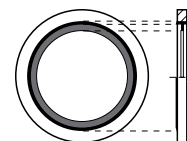

SS9500-02	SS9500-10	SS9500-24
SS9500-04	SS9500-12	SS9500-32
SS9500-06	SS9500-16	
SS9500-08	SS9500-20	

SS9500-MM

STAINLESS BONDED SEAL FOR
METRIC THREAD

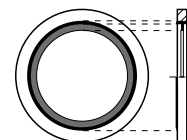

SS9500-06MM	SS9500-14MM	SS9500-22MM
SS9500-08MM	SS9500-16MM	SS9500-26MM
SS9500-10MM	SS9500-18MM	SS9500-30MM
SS9500-12MM	SS9500-20MM	

SS9500-V

STAINLESS BONDED SEAL FOR
BSPP THREAD (VITON)

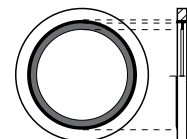

SS9500-02V	SS9500-10V
SS9500-04V	SS9500-12V
SS9500-06V	SS9500-16V
SS9500-08V	

STAINLESS STEEL INTERNATIONAL ADAPTERS

TUTORIALS

SS9500-MMV

STAINLESS BONDED SEAL FOR METRIC THREAD (VITON)

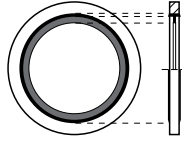

- SS9500-10MMV SS9500-20MMV
- SS9500-12MMV SS9500-24MMV
- SS9500-14MMV SS9500-26MMV
- SS9500-16MMV

FEATURED

SS9915

STAINLESS MALE BSPT X HOSE BARB

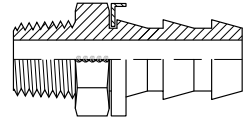

- SS9915-04-04 SS9915-12-12
- SS9915-06-06 SS9915-16-16
- SS9915-06-08 SS9915-20-20
- SS9915-08-08

STEEL

SS9605

STAINLESS MALE JIC X MALE METRIC DIN (LIGHT DUTY)

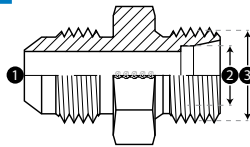

- SS9605-04-L06-12 SS9605-10-L15-22
- SS9605-04-L08-14 SS9605-12-L18-26
- SS9605-06-L10-16 SS9605-12-L22-30
- SS9605-06-L12-18 SS9605-16-L28-36
- SS9605-08-L12-18
- SS9605-08-L15-22

STAINLESS STEEL

SSRR

STAINLESS RETAINING RING BSPP

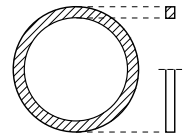

- SSRR-02 SSRR-06 SSRR-12
- SSRR-04 SSRR-08 SSRR-16

BRASS

SS9606

STAINLESS MALE JIC X MALE METRIC DIN (HEAVY DUTY)

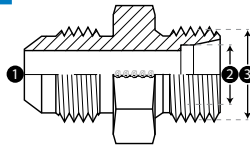

- SS9606-04-S06-14 SS9606-08-S16-24
- SS9606-04-S08-16 SS9606-10-S16-24
- SS9606-06-S10-18 SS9606-12-S20-30
- SS9606-06-S12-20 SS9606-12-S25-36
- SS9606-08-S10-18 SS9606-16-S30-42
- SS9606-08-S12-20

MEALLEABLE IRON

SS9900

STAINLESS FEMALE BSPP (SWIVEL) X HOSE BARB

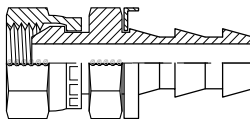

- SS9900-04-04 SS9900-08-08 SS9900-16-16
- SS9900-06-06 SS9900-12-12

QUICK REFERENCE

ABOUT

BRASS COMPRESSION, POLYTUBE & PUSH TO CONNECT

166

BRASS COMPRESSION X FEMALE BSP



166-04-02	166-06-04
166-04-04	166-06-06
166-05-02	166-08-08
166-05-04	

168

BRASS COMPRESSION X MALE BSPT



168-04-02	168-05-04	168-06-08
168-04-04	168-06-02	168-08-04
168-04-06	168-06-04	168-08-06
168-05-02	168-06-06	168-08-08

169

90° BRASS COMPRESSION X MALE BSPT ELBOW



169-04-02	169-05-04	169-08-04
169-04-04	169-06-04	169-08-06
169-04-06	169-06-06	169-08-08
169-05-02	169-06-08	

171

BRASS COMPRESSION X MALE BSPT RUN TEE



171-04-02	171-06-04
171-04-04	171-06-06
171-05-02	171-08-06
171-05-04	

172

BRASS COMPRESSION X MALE BSPT BRANCH TEE

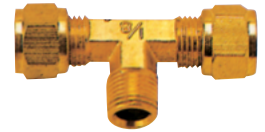

172-04-02	172-06-04
172-04-04	172-06-06
172-05-02	172-08-06
172-05-04	

266

BRASS POLYTUBE COMPRESSION X FEMALE BSP



266-04-02	266-06-06
266-04-04	266-08-06
266-05-04	
266-06-04	

268

BRASS POLYTUBE COMPRESSION X MALE BSPT



268-04-02	268-06-02	268-08-08
268-04-04	268-06-04	
268-04-06	268-06-06	
268-05-02	268-06-08	
268-05-04	268-08-04	
268-05-06	268-08-06	

269

90° BRASS POLYTUBE COMPRESSION X MALE BSPT ELBOW



269-04-02	269-05-06	269-08-06
269-04-04	269-06-02	269-08-08
269-04-06	269-06-04	
269-04-08	269-06-06	
269-05-02	269-06-08	
269-05-04	269-08-04	

TUTORIALS

FEATURED

STEEL

STAINLESS STEEL

BRASS

MEALLEABLE IRON QUICK REFERENCE

ABOUT

BRASS COMPRESSION, POLYTUBE & PUSH TO CONNECT

TUTORIALS

FEATURED

STEEL

STAINLESS STEEL

BRASS

MEALLEABLE IRON

QUICK REFERENCE

ABOUT

270

90° BRASS POLYTUBE COMPRESSION X FEMALE BSP ELBOW



270-04-02	270-06-06
270-04-04	270-08-06
270-05-04	
270-06-04	

568

BRASS PUSH TO CONNECT X MALE BSPT



568-02-02	568-05-04	568-06-08
568-04-04	568-06-02	568-08-04
568-04-06	568-06-04	568-08-06
568-05-02	568-06-06	568-08-08

271

BRASS POLYTUBE COMPRESSION X MALE BSPT RUN TEE

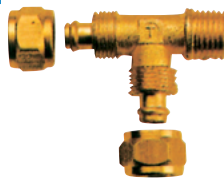

271-04-02	271-06-04
271-04-04	271-06-06
271-05-02	271-08-06
271-05-04	271-08-08

569

90° BRASS PUSH TO CONNECT X MALE BSPT ELBOW



569-04-02	569-05-06	569-06-08
569-04-04	569-06-02	569-08-04
569-05-02	569-06-04	569-08-06
569-05-04	569-06-06	569-08-08

272

BRASS POLYTUBE COMPRESSION X MALE BSPT BRANCH TEE



272-04-02	272-05-04	272-08-08
272-04-04	272-06-04	
272-04-06	272-06-06	
272-05-02	272-08-06	

569BJ

90° BRASS BANJO PUSH TO CONNECT X MALE BSPT ELBOW



569BJ-04-02	569BJ-05-04
569BJ-04-04	569BJ-06-04
569BJ-04-06	569BJ-06-06
569BJ-05-02	

566

BRASS PUSH TO CONNECT X FEMALE BSPT



566-04-02	566-05-06
566-04-04	566-06-04
566-05-02	566-06-06
566-05-04	566-06-08

569L

90° BRASS BANJO PUSH TO CONNECT X MALE BSPT ELBOW LONG



569L-04-02	569L-06-04
569L-04-04	569L-06-06
569L-05-02	569L-08-06
569L-05-04	

BRASS COMPRESSION, POLYTUBE & PUSH TO CONNECT

571

BRASS PUSH TO CONNECT X
MALE BSPT RUN TEE



571-04-02	571-06-02
571-04-04	571-06-04
571-05-02	571-06-06
571-05-04	

582

BRASS PUSH TO CONNECT
FLOW CONTROL VALVE X
MALE BSPT



582-04-02	582-06-02
582-04-04	582-06-04
582-05-02	582-06-06
582-05-04	

572

BRASS PUSH TO CONNECT X
MALE BSPT BRANCH TEE



572-04-02	572-06-04	572-08-08
572-04-04	572-06-06	
572-05-02	572-08-04	
572-05-04	572-08-06	

575

BRASS PUSH TO CONNECT X
MALE BSPT BRANCH "Y"



575-04-02	575-05-02	575-06-04
575-04-04	575-05-04	575-06-06

581

90° BRASS PUSH TO CONNECT
METERING IN VALVE X MALE
BSPT



581-04-02	581-06-02
581-04-04	581-06-04
581-05-02	581-06-06
581-05-04	

TUTORIALS

FEATURED

STEEL

STAINLESS STEEL

BRASS

MEALLEABLE IRON

QUICK REFERENCE

ABOUT

BRASS INTERNATIONAL ADAPTERS

TUTORIALS

FEATURED

STEEL

STAINLESS STEEL

BRASS

MEALLEABLE IRON

QUICK REFERENCE

ABOUT

8000

BRASS MALE BSPP NIPPLE

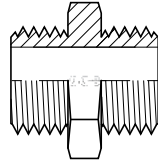

- | | | |
|------------|------------|------------|
| 8000-02-02 | 8000-08-04 | 8000-16-16 |
| 8000-04-02 | 8000-08-06 | 8000-24-20 |
| 8000-04-04 | 8000-08-08 | |
| 8000-06-02 | 8000-12-08 | |
| 8000-06-04 | 8000-12-12 | |
| 8000-06-06 | 8000-16-12 | |

8007

BRASS MALE BSPP X MALE NPT

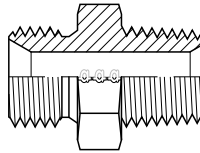

- | | |
|------------|------------|
| 8007-04-04 | 8007-06-06 |
| 8007-06-04 | 8007-08-08 |

8008

BRASS MALE BSPT X MALE NPT

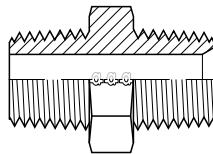

- | | |
|------------|------------|
| 8008-02-02 | 8008-08-08 |
| 8008-02-04 | 8008-12-12 |
| 8008-04-04 | 8008-16-16 |
| 8008-06-06 | |

8010

BRASS MALE BSPT NIPPLE

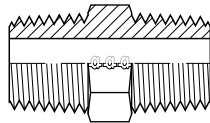

- | | | |
|------------|------------|------------|
| 8010-02-02 | 8010-08-04 | 8010-16-12 |
| 8010-04-02 | 8010-08-06 | 8010-16-16 |
| 8010-04-04 | 8010-08-08 | |
| 8010-06-02 | 8010-12-06 | |
| 8010-06-04 | 8010-12-08 | |
| 8010-06-06 | 8010-12-12 | |

8011

BRASS MALE JIC X MALE BSPT

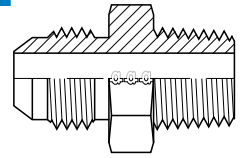

- | | | |
|------------|------------|------------|
| 8011-04-02 | 8011-06-06 | 8011-08-08 |
| 8011-04-04 | 8011-08-06 | 8011-12-12 |

8028

BRASS COUNTERSUNK BSPP SEALED PLUG

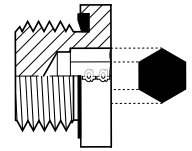

- | | |
|---------|---------|
| 8028-02 | 8028-06 |
| 8028-04 | 8028-08 |

8030CSP

BRASS COUNTERSUNK BSPT PLUG

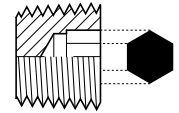

- | | | |
|------------|------------|------------|
| 8030CSP-02 | 8030CSP-06 | 8030CSP-12 |
| 8030CSP-04 | 8030CSP-08 | 8030CSP-16 |

8033

BRASS BSP SOLID CAP

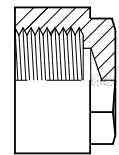

- | | | |
|---------|---------|---------|
| 8033-02 | 8033-06 | 8033-12 |
| 8033-04 | 8033-08 | |

8035

BRASS MALE BSPP X FEMALE NPT

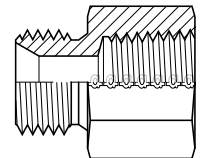

- | | | |
|------------|------------|------------|
| 8035-02-02 | 8035-06-06 | 8035-20-20 |
| 8035-04-02 | 8035-08-08 | |
| 8035-04-04 | 8035-12-12 | |
| 8035-04-06 | 8035-16-16 | |

BRASS INTERNATIONAL ADAPTERS

8036

BRASS MALE BSPT X FEMALE NPT

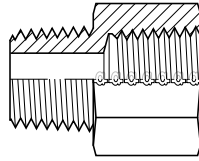

8036-02-02	8036-12-12
8036-04-04	8036-16-08
8036-06-06	8036-16-16
8036-08-08	

8037

BRASS MALE NPT X FEMALE BSP

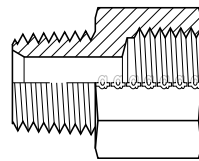

8037-02-02	8037-06-06	8037-12-12
8037-04-04	8037-08-08	

8037T

BRASS MALE NPT X FEMALE BSPT

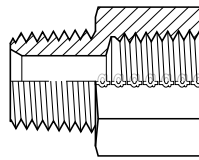

8037T-02-02	8037T-08-12
8037T-04-04	8037T-12-12
8037T-06-06	8037T-16-16
8037T-08-08	8037T-20-20

8038

BRASS MALE BSPT X FEMALE BSP BUSHING

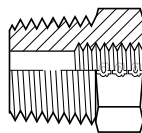

8038-02-02	8038-04-08	8038-12-06
8038-02-04	8038-06-02	8038-12-08
8038-02-06	8038-06-04	8038-16-12
8038-04-02	8038-06-06	
8038-04-04	8038-08-04	
8038-04-06	8038-08-06	

8039

BRASS MALE BSPP X FEMALE BSP BUSHING

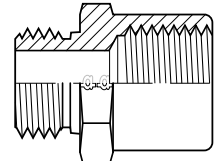

8039-02-02	8039-06-04	8039-08-08
8039-02-04	8039-06-06	8039-12-04
8039-04-02	8039-06-08	8039-12-06
8039-04-04	8039-08-02	8039-12-08
8039-04-06	8039-08-04	8039-16-12
8039-06-02	8039-08-06	

8043

BRASS FEMALE BSP X FEMALE BSP

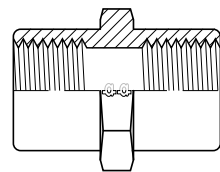

8043-02-02	8043-06-04	8043-08-08
8043-04-02	8043-06-06	8043-12-12
8043-04-04	8043-08-04	
8043-06-02	8043-08-06	

8044

BRASS FEMALE BSP X FEMALE NPT

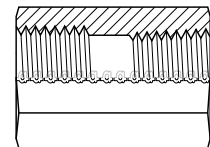

8044-02-02	8044-08-04	8044-24-24
8044-04-04	8044-08-08	8044-32-32
8044-06-04	8044-16-16	
8044-06-06	8044-20-20	

8055

BRASS 90° MALE BSPT ELBOW

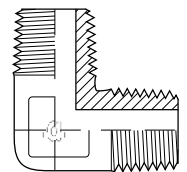

8055-02-02	8055-06-06	8055-12-12
8055-04-04	8055-08-08	

TUTORIALS

FEATURED

STEEL

STAINLESS STEEL

BRASS

MEALLEABLE IRON

QUICK REFERENCE

ABOUT

BRASS INTERNATIONAL ADAPTERS

TUTORIALS

FEATURED

STEEL

STAINLESS STEEL

BRASS

MEALLEABLE IRON

QUICK REFERENCE

ABOUT

8060

BRASS 90° MALE BSPT X FEMALE BSP ELBOW

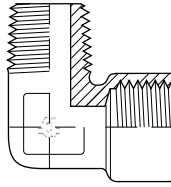

- 8060-02-02
- 8060-06-06
- 8060-12-12
- 8060-04-04
- 8060-08-08

8075

BRASS 90° FEMALE BSP ELBOW

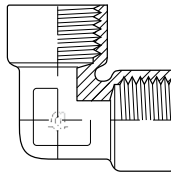

- 8075-02-02
- 8075-06-06
- 8075-12-12
- 8075-04-04
- 8075-08-08

8080

BRASS MALE BSPT TEE

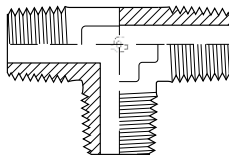

- 8080-02-02-02
- 8080-06-06-06
- 8080-12-12-12
- 8080-04-04-04
- 8080-08-08-08

8085

BRASS FEMALE BSP TEE

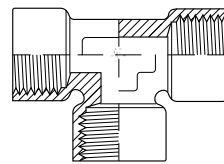

- 8085-02-02-02
- 8085-06-06-06
- 8085-12-12-12
- 8085-04-04-04
- 8085-08-08-08

8093

BRASS FEMALE BSP X MALE BSPT BRANCH TEE

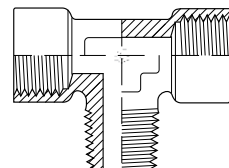

- 8093-02-02-02
- 8093-06-06-06
- 8093-12-12-12
- 8093-04-04-04
- 8093-08-08-08

8095

BRASS FEMALE BSP X MALE BSPT RUN TEE

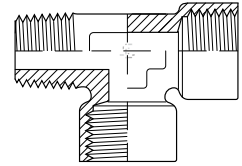

- 8095-02-02-02
- 8095-06-06-06
- 8095-12-12-12
- 8095-04-04-04
- 8095-08-08-08

8097

BRASS FEMALE BSP CROSS

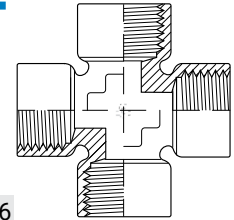

- 8097-02-02-02-02
- 8097-06-06-06-06
- 8097-12-12-12-12
- 8097-04-04-04-04
- 8097-08-08-08-08

8235

BRASS MALE METRIC X FEMALE NPT

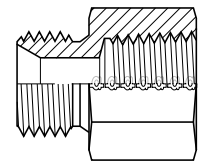

- 8235-14-02
- 8235-16-06
- 8235-22-06
- 8235-14-04
- 8235-18-08

8400

ALUMINUM WASHER BSPP THREAD

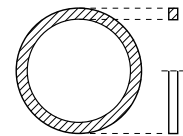

- 8400-04
- 8400-08
- 8400-06
- 8400-12

8900

BRASS FEMALE BSPP (SWIVEL) X HOSE BARB

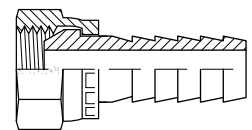

- 8900-04-04
- 8900-06-08
- 8900-12-12
- 8900-06-06
- 8900-08-08

BRASS INTERNATIONAL ADAPTERS

8920

BRASS MALE BSPP X
HOSE BARB

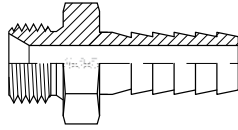

8920-04-06
8920-04-08

8920-08-08
8920-12-12

8920-16-16

8920T

MALE BSPT X HOSE BARB

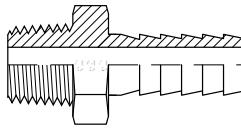

8920T-02-02

8920T-04-08

8920T-12-12

8920T-02-03

8920T-06-04

8920T-16-16

8920T-02-04

8920T-06-06

8920T-20-20

8920T-02-05

8920T-06-08

8920T-24-24

8920T-02-06

8920T-08-06

8920T-32-32

8920T-04-03

8920T-08-08

8920T-04-04

8920T-08-12

8920T-04-06

8920T-12-08

TUTORIALS

FEATURED

STEEL

STAINLESS STEEL

BRASS

MEALLEABLE IRON

QUICK REFERENCE

ABOUT

BSP BLACK PIPE/MALLEABLE IRON

TUTORIALS
FEATURED
STEEL
STAINLESS STEEL
BRASS
MALLEABLE IRON
QUICK REFERENCE
ABOUT

B14C

BLACK BSP CAP



B14C-04	B14C-16	B14C-40
B14C-06	B14C-20	B14C-48
B14C-08	B14C-24	
B14C-12	B14C-32	

B1404

BLACK BSP COUPLING



B1404-04-04	B1404-16-16	B1404-32-24
B1404-06-04	B1404-20-16	B1404-32-32
B1404-06-06	B1404-20-20	B1404-40-32
B1404-08-04	B1404-24-08	B1404-40-40
B1404-08-06	B1404-24-20	B1404-48-40
B1404-08-08	B1404-24-24	B1404-48-48
B1404-12-08	B1404-32-08	
B1404-12-12	B1404-32-12	
B1404-16-08	B1404-32-16	
B1404-16-12	B1404-32-20	

B1404U

BLACK BSP UNION

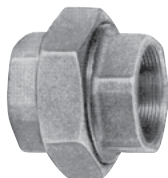

B1404U-02-02	B1404U-12-12	B1404U-32-32
B1404U-04-04	B1404U-16-16	B1404U-40-40
B1404U-06-06	B1404U-20-20	B1404U-48-48
B1404U-08-08	B1404U-24-24	

B1804

BLACK BSPT BUSHING



B1804-04-02	B1804-16-08	B1804-32-20
B1804-06-02	B1804-16-12	B1804-32-24
B1804-06-04	B1804-20-08	B1804-40-20
B1804-08-02	B1804-20-12	B1804-40-24
B1804-08-04	B1804-20-16	B1804-40-32
B1804-08-06	B1804-24-08	B1804-48-24
B1804-12-04	B1804-24-12	B1804-48-32
B1804-12-06	B1804-24-16	B1804-48-40
B1804-12-08	B1804-24-20	
B1804-16-06	B1804-32-16	

B1808H

BLACK BSPT NIPPLE

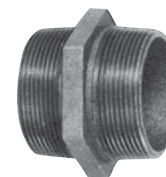

B1808H-04-02	B1808H-12-12	B1808H-32-20
B1808H-04-04	B1808H-16-08	B1808H-32-24
B1808H-06-02	B1808H-16-12	B1808H-32-32
B1808H-06-04	B1808H-16-16	B1808H-40-32
B1808H-06-06	B1808H-20-12	B1808H-40-40
B1808H-08-04	B1808H-20-16	B1808H-48-48
B1808H-08-06	B1808H-20-20	
B1808H-08-08	B1808H-24-16	
B1808H-12-06	B1808H-24-20	
B1808H-12-08	B1808H-24-24	

B1808L

BLACK LONG BSPT NIPPLE



B1808L-04-40MM	B1808L-12-40MM
B1808L-04-60MM	B1808L-12-60MM
B1808L-04-80MM	B1808L-12-80MM
B1808L-04-120MM	B1808L-16-40MM
B1808L-06-40MM	B1808L-16-60MM
B1808L-06-60MM	B1808L-16-80MM
B1808L-06-80MM	B1808L-20-150MM
B1808L-08-40MM	B1808L-20-400MM
B1808L-08-60MM	B1808L-20-4"
B1808L-08-80MM	B1808L-20-10"

BSP BLACK PIPE/MALLEABLE IRON

B18SQP

BLACK BSPT SQUARE HEAD PLUG



B18SQP-04	B18SQP-16	B18SQP-40
B18SQP-06	B18SQP-20	B18SQP-48
B18SQP-08	B18SQP-24	
B18SQP-12	B18SQP-32	

B2404

BLACK BSP 45° FEMALE ELBOW



B2404-06-06	B2404-20-20
B2404-08-08	B2404-24-24
B2404-12-12	B2404-32-32
B2404-16-16	

B2804

BLACK 45° BSPT STREET ELBOW



B2804-06-06	B2804-12-12	B2804-20-20
B2804-08-08	B2804-16-16	

B3404

BLACK BSP 90° FEMALE ELBOW

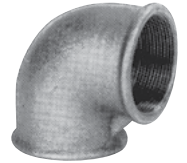

B3404-02-02	B3404-12-08	B3404-24-16
B3404-04-04	B3404-12-12	B3404-24-20
B3404-06-04	B3404-16-08	B3404-24-24
B3404-06-06	B3404-16-12	B3404-32-32
B3404-08-04	B3404-16-16	B3404-40-40
B3404-08-06	B3404-20-12	B3404-48-48
B3404-08-08	B3404-20-16	
B3404-12-06	B3404-20-20	

B3804

BLACK 90° BSPT STREET ELBOW



B3804-04-04	B3804-16-16	B3804-40-40
B3804-06-06	B3804-20-20	B3804-48-48
B3804-08-08	B3804-24-24	
B3804-12-12	B3804-32-32	

B4444

BLACK BSP FEMALE TEE



B4444-04	B4444-24	B4444-48
B4444-06	B4444-24-08-20	
B4444-08	B4444-24-20-24	
B4444-12	B4444-32	
B4444-16	B4444-32-32-08	
B4444-20	B4444-40	

QUICK REFERENCE

INSTRUCTIONS

1. The thread types for each description are displayed hose/tube and/or male side first, then port and/or female side.
2. If both sides of a fitting are the same (both hose/tube or both port) they are displayed alphabetically.
3. Part descriptions are then arranged in alphabetical order, with males appearing before females. For example, a male BSPP is typically the first listed while a female is last.
4. Thread types are displayed first to allow for quick searching along the margin (as opposed to thread gender first which is common).

STRAIGHT FITTINGS - MALE X MALE

DESCRIPTIONS	STEEL		STAINLESS		BRASS		BLACK PIPE	
	SERIES	PAGE	SERIES	PAGE	SERIES	PAGE	SERIES	PAGE
BSPP MALE X BSPP MALE	9000	47	SS9000	81	8000	90		
BSPP MALE X BSPP MALE BULKHEAD	9040	57	SS9040	84				
BSPP MALE X BSPP MALE BULKHEAD LONG	9040L	57						
BSPP MALE X BSPP MALE ADJ. OR+RR	9474	70						
BSPP MALE X BSPT MALE	9003	48	SS9003	81				
BSPP MALE X METRIC MALE	9004	48						
BSPP MALE X METRIC MALE BULKHEAD	9040M	57						
BSPP MALE X NPT MALE	9007	50	SS9007	81	8007	90		
BSPP MALE X ORB MALE	9006	49	SS9006	81				
BSPT MALE X BSPT MALE	9010	50	SS9010	82	8010	90	B1808H	94
BSPT MALE X BSPT MALE LONG							B1808L	94
BSPT MALE X NPT MALE	9008	50	SS9008	82	8008	90		

STRAIGHT FITTINGS - MALE X MALE

DESCRIPTIONS	STEEL		STAINLESS		BRASS		BLACK PIPE	
	SERIES	PAGE	SERIES	PAGE	SERIES	PAGE	SERIES	PAGE
DIN MALE X BSPP MALE ES SEAL	5002	31	SS5002	76				
DIN MALE X BSPP MALE SHOULDER SEAL			SS5001	76				
DIN MALE X BSPP MALE BULKHEAD	5040ES	33						
DIN MALE X BSPT MALE	5011	33						
DIN MALE X DIN MALE	5000	31	SS5000	76				
DIN MALE X DIN MALE BULKHEAD	5040	33	SS5040	77				
DIN MALE X JIC MALE (LIGHT)	9605	71	SS9605	86				
DIN MALE X JIC MALE OR+RR (LIGHT)	9605S	71						
DIN MALE X JIC MALE (HEAVY)	9606	71	SS9606	86				
DIN MALE X JIC MALE OR+RR (HEAVY)	9606S	72						
DIN METRIC MALE (JSW) X JIC MALE	9245	67						
DIN MALE X METRIC MALE ES SEAL	5068	36	SS5068	78				
DIN MALE X METRIC TAPER MALE	5068LLT	36						
DIN MALE (TUBE ONLY) X NPT MALE	5007	32	SS5007	76				
DIN MALE (PORT & TUBE) X NPT MALE	9607	72						
DIN MALE X ORB MALE	5006	31						
DIN MALE X ORFS MALE (LIGHT)	6605	46						
DIN MALE X ORFS MALE (HEAVY)	6606	47						
JIC MALE X BSPP MALE	9005	49	SS9005	81				
JIC MALE X BSPP MALE ES SEAL	9005ES	49						
JIC MALE X BSPP MALE OR+RR	9002	48	SS9002	81				
JIC MALE X BSPP MALE EXTRA LONG	9005EL	49						
JIC MALE X BSPP MALE LONG	9005L	49						
JIC MALE X BSPP MALE LONG OR+RR	9002L	48						
JIC MALE X BSPT MALE	9011	50	SS9011	82	8011	90		
JIC MALE X JIS MALE	9337	69						
JIC MALE X KOBELCO MALE	9247	67						
JIC MALE X KOMATSU MALE	9237	67						
JIC MALE X METRIC MALE	9067	61						
JIC MALE X METRIC MALE OR+RR	9068	61						
JIC MALE X NISSAN MALE	9228	65						
JIC MALE X ORFS MALE	6622	47						

QUICK REFERENCE

STRAIGHT FITTINGS - MALE X MALE

DESCRIPTIONS	STEEL		STAINLESS		BRASS		BLACK PIPE	
	SERIES	PAGE	SERIES	PAGE	SERIES	PAGE	SERIES	PAGE
JIS MALE X BSPT MALE	9223	65						
JIS MALE X JIS MALE	9336	69						
JIS MALE X ORB MALE	9277	68						
JIS MALE X ORFS MALE	6337	46						
KOBELCO MALE X ORFS MALE	6247	46						
KOMATSU MALE X BSPT MALE	9233	66						
KOMATSU MALE X KOMATSU MALE	9236	67						
KOMATSU MALE X ORFS MALE	6237	46						
METRIC MALE X METRIC MALE	9001	48						
ORFS MALE X BSPP MALE OR+RR	6002	44						
ORFS MALE X BSPP MALE	6005	44						
ORFS MALE X BSPT MALE SHORT	6011	45						
ORFS MALE X METRIC MALE OR+RR	6068	45						

TUTORIALS

FEATURED

STEEL

STAINLESS STEEL

BRASS

MEALLEABLE IRON

QUICK REFERENCE

ABOUT

STRAIGHT FITTINGS - MALE X FEMALE

DESCRIPTIONS	STEEL		STAINLESS		BRASS		BLACK PIPE	
	SERIES	PAGE	SERIES	PAGE	SERIES	PAGE	SERIES	PAGE
BSPP MALE X BSPP FEMALE SWIVEL	9015	51	SS9015	82				
BSPP MALE X BSP FEMALE BUSHING	9038	56	SS9038	83	8039	91		
BSPP MALE X BSP FEMALE BUSHING ES SEAL	9038ES	56						
BSPP MALE X BSP FEMALE LONG BUSHING	9039	56	SS9039	84	8039	91		
BSPP MALE X BSP FEMALE LONG BUSHING ES SEAL	9039ES	56						
BSPP MALE X BSPT FEMALE	9034	55						
BSPP MALE X DIN FEMALE ES SEAL	5302	41						
BSPP MALE X JIC FEMALE SWIVEL	9021	52	SS9021	82				
BSPP MALE X METRIC FEMALE SWIVEL	9019	51						
BSPP MALE X NPT FEMALE	9035	55			8035	90		
BSPP MALE X NPT FEMALE OR+RR	9035S	55	SS9035S	83				
BSPP MALE X ORB FEMALE	9036	56						
BSPT MALE X BSP FEMALE SOLID	9032	55			8038	91		
BSPT MALE X BSPP FEMALE SWIVEL	9032S	55						
BSPT MALE X BSPT FEMALE BUSHING	9031	54					B1804	94
BSPT MALE X NPT FEMALE	9042	57	SS9042	84	8036	91		
BSPT MALE X ORB FEMALE	9536	70						
DIN MALE X BSP FEMALE SOLID	5009	32						
DIN MALE X BSP FEMALE GAUGE COUPLING	5009GC	32						
DIN MALE X DIN FEMALE REDUCER	5315	42	SS5315	79				
DIN MALE X JIC FEMALE SOLID	9624	72						
DIN MALE X NPT FEMALE OR+RR (LIGHT)	9635S	72						
DIN MALE X NPT FEMALE OR+RR (HEAVY)	9636S	73						

TUTORIALS

FEATURED

STEEL

STAINLESS STEEL

BRASS

MEALLEABLE IRON

QUICK REFERENCE

ABOUT

QUICK REFERENCE

STRAIGHT FITTINGS - MALE X FEMALE

DESCRIPTIONS	STEEL		STAINLESS		BRASS		BLACK PIPE	
	SERIES	PAGE	SERIES	PAGE	SERIES	PAGE	SERIES	PAGE
JIC MALE X BSP FEMALE SOLID	9009	50	SS9009	82				
JIC MALE X BSPP FEMALE SWIVEL	9240	67	SS9240	85				
JIC MALE X DIN FEMALE SWIVEL	9197	64						
JIC MALE X HIAB FEMALE SWIVEL	9210	65						
JIC MALE X JIC FEMALE SOLID	9020C	52						
JIC MALE X JIC FEMALE SWIVEL	9020	51	SS9020	82				
JIC MALE X JIS FEMALE SOLID	9220	65						
JIC MALE X KOMATSU FEMALE SOLID	9230	66						
JIC MALE X METRIC FEMALE SWIVEL	9022	52						
JIC MALE X METRIC FEMALE FLAT FACE	9022F	52						
JIC MALE X METRIC FEMALE FLAT FACE SHORT	9022FC	52						
JIC MALE X METRIC FEMALE SOLID	9622	72						
JIC MALE X NISSAN FEMALE SOLID	9229	66						
JIC MALE X ORFS FEMALE SWIVEL	6620	47						
METRIC MALE X BSPP FEMALE SWIVEL	9018	51						
METRIC MALE X BSPT FEMALE	9234	66						
METRIC MALE X DIN FEMALE ES SEAL	5368	43						
METRIC MALE X JIC FEMALE SWIVEL	9024	53						
METRIC MALE X JIC FEMALE SWIVEL OR+RR	9024S	53						
METRIC MALE X METRIC FEMALE BUSHING	9638	73						
METRIC MALE X NPT FEMALE	9235	66	SS9235	85	8235	92		
METRIC MALE X ORB FEMALE	9335	69						
NPT MALE X BSP FEMALE SOLID	9037	56	SS9037	83	8037	91		
NPT MALE X BSPP FEMALE SWIVEL	9023	52						
NPT MALE X BSPT FEMALE					8037T	91		
NPT MALE X DIN FEMALE	5307	41						
NPT MALE X JIC FEMALE SWIVEL	9017	51						
NPT MALE X METRIC FEMALE SOLID	9325	68						
ORB MALE X BSP FEMALE SOLID	9120	63						
ORFS MALE X JIC FEMALE SWIVEL	6621	47						
ORFS MALE X JIS FEMALE SOLID	6220	46						
ORFS MALE X KOMATSU FEMALE SOLID	6230	46						

STRAIGHT FITTINGS - FEMALE X FEMALE

DESCRIPTIONS	STEEL		STAINLESS		BRASS		BLACK PIPE	
	SERIES	PAGE	SERIES	PAGE	SERIES	PAGE	SERIES	PAGE
BSP FEMALE X BSP FEMALE SOLID	9043	57	SS9043	84	8043	91	B1404	94
BSPP FEMALE X BSPP FEMALE SWIVEL	9025	53					B1404U	94
BSP FEMALE X NPT FEMALE SOLID	9044	58			8044	91		
DIN FEMALE X BSP FEMALE GAUGE COUPLING	5309GC	41						
DIN FEMALE X DIN FEMALE	5300	41	SS5300	79				
JIC FEMALE X BSPP FEMALE SWIVEL	9027	53						
JIC FEMALE X JIC FEMALE SWIVEL	9026	53	SS9026	82				
JIC FEMALE X JIS FEMALE SWIVEL	9226	65						
KOMATSU FEMALE X KOMATSU FEMALE SWIVEL	9327	69						
METRIC FEMALE X METRIC FEMALE SOLID	9043M	58						
METRIC FEMALE X NPT FEMALE SOLID	9643	73						

TUTORIALS

FEATURED

STEEL

STAINLESS STEEL

BRASS

MEALLEABLE IRON

QUICK REFERENCE

ABOUT

QUICK REFERENCE

STRAIGHT FITTINGS - OTHER/MISC

DESCRIPTIONS	STEEL		STAINLESS		BRASS		BLACK PIPE	
	SERIES	PAGE	SERIES	PAGE	SERIES	PAGE	SERIES	PAGE
BRASS COMPRESSION X BSP FEMALE					166	87		
BRASS COMPRESSION X BSPT MALE					168	87		
BRASS POLYTUBE COMPR. X BSP FEMALE					266	87		
BRASS POLYTUBE COMPR. X BSPT MALE					268	87		
BRASS PUSH TO CON. X BSPT MALE					568	88		
BRASS PUSH TO CON. X BSPT FEMALE					566	88		
BRASS PUSH TO CON. FLOW VALVE X BSPT MALE					582	89		
BSPP MALE X HOSE BARB	9920	74			8920	93		
BSPP MALE X HOSE BARB (NEEDS CLAMP)	9921	74						
BSPP FEMALE SWIVEL X HOSE BARB	9900	73	SS9900	86	8900	92		
BSPT MALE X HOSE BARB	9915	73	SS9915	86	8920T	93		
JIC MALE X DIN STANDPIPE	9200	64	SS9200	85				

TUTORIALS

FEATURED

STEEL

STAINLESS STEEL

BRASS

MEALLEABLE IRON

QUICK REFERENCE

ABOUT

45° ELBOWS

DESCRIPTIONS	STEEL		STAINLESS		BRASS		BLACK PIPE	
	SERIES	PAGE	SERIES	PAGE	SERIES	PAGE	SERIES	PAGE
BSPP MALE X BSPP MALE ADJ.	9051	58						
BSPP MALE X BSPP FEMALE SWIVEL	9048	58						
BSPP MALE X BSPP FEMALE SWIVEL (TUBE)	9047	58						
BSPP MALE X BSPT MALE	9054	59						
BSP FEMALE X BSP FEMALE SOLID							B2404	95
BSPP FEMALE X BSPP FEMALE SWIVEL	9053	59						
BSPP FEMALE X HOSE BARB SWIVEL	9905	73						
BSPT MALE X BSP FEMALE							B2804	95
DIN MALE X BSPP MALE ADJ.	5058	34						
DIN MALE X DIN FEMALE	5362	43						
DIN MALE X METRIC MALE ADJ.	5066	35						
JIC MALE X BSPP MALE ADJ.	9058	59	SS9058	84				
JIC MALE X BSPP FEMALE SWIVEL	9260	68						
JIC MALE X BSPT MALE	9064	60						
JIC MALE X METRIC MALE ADJ.	9066	60						
JIS MALE X BSPT MALE	9225	65						
JIS MALE X JIS FEMALE SWIVEL	9294	68						
ORFS MALE X BSPP MALE ADJ.	6058	45						

TUTORIALS

FEATURED

STEEL

STAINLESS STEEL

BRASS

MEALLEABLE IRON

QUICK REFERENCE

ABOUT

QUICK REFERENCE

90° ELBOWS

DESCRIPTIONS	STEEL		STAINLESS		BRASS		BLACK PIPE	
	SERIES	PAGE	SERIES	PAGE	SERIES	PAGE	SERIES	PAGE
BRASS COMPRESSION X BSPT MALE					169	87		
BRASS POLYTUBE COMPR. X BSP FEMALE					270	88		
BRASS POLYTUBE COMPR. X BSPT MALE					269	87		
BRASS PUSH TO CON. X BSPT MALE					569	88		
BRASS PUSH TO CON. X BSPT MALE BANJO					569BJ	88		
BRASS PUSH TO CON. X BSPT MALE METERING VALVE					581	89		
BSPP MALE X BSPP MALE	9055	59						
BSPP MALE X BSPP MALE ADJ.	9052	59						
BSPP MALE X BSPP FEMALE SWIVEL	9060	60						
BSPP MALE X BSPP FEMALE SWIVEL (TUBE)	9045	58						
BSPP MALE ADJ. X BSPP FEMALE SWIVEL	9046	58						
BSPP MALE X BSPT MALE	9057	59						
BSPP MALE X HOSE BARB BANJO	3059HB	29						
BSPP MALE X JIC FEMALE SWIVEL	9061	60						
BSPP MALE X NPT MALE	9070	61						
BSPP MALE ADJ. X NPT FEMALE	9135	63						
BSPP MALE X ORB MALE ADJ.	9077	62						
BSP FEMALE X BSP FEMALE SOLID	9076	62			8075	92	B3404	95
BSPP FEMALE X BSPP FEMALE SWIVEL	9075	61						
BSPP FEMALE X BSPP FEMALE SWIVEL (TUBE)	9050	58						
BSPP FEMALE X HOSE BARB SWIVEL	9910	73						
BSPT MALE X BSP FEMALE SOLID					8060	92	B3804	95
BSPT MALE X BSPP FEMALE SWIVEL	9062	60						
BSPT MALE X BSPT MALE					8055	91		
BSPT MALE X BSPT FEMALE							B3804	95

90° ELBOWS

DESCRIPTIONS	STEEL		STAINLESS		BRASS		BLACK PIPE	
	SERIES	PAGE	SERIES	PAGE	SERIES	PAGE	SERIES	PAGE
DIN MALE X BSPP MALE ADJ.	5059	35	SS5059	77				
DIN MALE X BSPP MALE BANJO	3059	29						
DIN MALE X BSPP MALE ES SEAL BANJO	5059BJ	34						
DIN MALE X BSPT MALE	5063	35						
DIN MALE X DIN MALE	5055	34	SS5055	77				
DIN MALE X DIN MALE BULKHEAD	5042	34	SS5042	77				
DIN MALE X DIN FEMALE	5360	42	SS5360	80				
DIN MALE X METRIC MALE ADJ.	5069	36						
DIN MALE X METRIC MALE BANJO	3069DIN	30						
DIN MALE X METRIC MALE ES SEAL BANJO	5069BJ	36						
DIN MALE X METRIC TAPER MALE	5069LLT	36						
DIN MALE X NPT MALE	5070	37						
DIN MALE X ORB MALE ADJ.	5077	37						
JIC MALE X BSPP MALE	9065	60						
JIC MALE X BSPP MALE ADJ.	9059	59	SS9059	84				
JIC MALE X BSPP MALE ADJ. LONG	9059L	60						
JIC MALE X BSPP MALE BANJO	3059	29						
JIC MALE X BSPP FEMALE SWIVEL	9056	59	SS9056	84				
JIC MALE X BSPP FEMALE SWIVEL (TUBE)	9250	67						
JIC MALE X BSPT MALE	9063	60	SS9063	85				
JIC MALE X DIN FEMALE SWIVEL	9199	64						
JIC MALE X JIC FEMALE SWIVEL	3705	44						
JIC MALE X METRIC MALE ADJ.	9069	61	SS9069	85				
JIC MALE X METRIC MALE ADJ. LONG	9069L	61						
JIC MALE X METRIC MALE BANJO	3069	30						
JIC MALE X UNF MALE BANJO	3049	29						
JIC FEMALE X JIC FEMALE SWIVEL	9355	69						

TUTORIALS

FEATURED

STEEL

STAINLESS STEEL

BRASS

MEALLEABLE IRON

QUICK REFERENCE

ABOUT

QUICK REFERENCE

90° ELBOWS

DESCRIPTIONS	STEEL		STAINLESS		BRASS		BLACK PIPE	
	SERIES	PAGE	SERIES	PAGE	SERIES	PAGE	SERIES	PAGE
JIS MALE X BSPP MALE ADJ.	9259	68						
JIS MALE X BSPT MALE	9224	65						
JIS MALE X JIS FEMALE SWIVEL	9292	68						
JIS MALE X ORB MALE ADJ.	9278	68						
KOMATSU MALE X KOMATSU FEMALE SWIVEL	9392	69						
METRIC MALE X HOSE BARB BANJO	3069HB	30						
NPT MALE X BSPP FEMALE SWIVEL	9072	61						
ORFS MALE X BSPP MALE ADJ.	6059	45						
ORFS MALE X METRIC MALE ADJ.	6069	45						
WELD (INCH) X UNF BANJO BODY	3049W	29						
WELD (METRIC) X METRIC BANJO BODY	3069W	30						

TUTORIALS

FEATURED

STEEL

STAINLESS STEEL

BRASS

MEALLEABLE IRON

QUICK REFERENCE

ABOUT

PLUGS & CAPS

DESCRIPTIONS	STEEL		STAINLESS		BRASS		BLACK PIPE	
	SERIES	PAGE	SERIES	PAGE	SERIES	PAGE	SERIES	PAGE
BSPP SOLID CAP	9033F	55			8033	90	B14C	94
BSPP SWIVEL CAP	9033	55	SS9033	83				
DIN TUBE CAP	5204	40	SS5204	79				
DIN TUBE BLANKING PLUG FOR DIN NUT	5204P	40	SS5204P	79				
JIS SWIVEL CAP	9222	65						
KOBELCO SWIVEL CAP	9249	67						
KOMATSU SWIVEL CAP	9232	66						
BSPP PLUG	9030	54	SS9030	83				
BSPP COUNTERSUNK SEALED PLUG	9028	53	SS9028	83	8028	90		
BSPT PLUG	9030T	54	SS9030T	83			B18SQP	95
BSPT COUNTERSUNK PLUG	9030TCSP	54			8030CSP	90		
DIN TUBE PLUG	5203	40	SS5203	78				
DIN TUBE (JSW) PLUG	9246	67						
JIS PLUG	9221	65						
KOBELCO TUBE PLUG	9248	67						
KOMATSU PLUG	9231	66						
METRIC PLUG	9030M	54						
METRIC COUNTERSUNK SEALED PLUG	9029	54	SS9029	83				
METRIC COUNTERSUNK PLUG (NO SEAL)	9029A	54						
METRIC ISO 6149 COUNTERSUNK SEALED PLUG	9030M-ISO	54						

TUTORIALS

FEATURED

STEEL

STAINLESS STEEL

BRASS

MEALLEABLE IRON

QUICK REFERENCE

ABOUT

QUICK REFERENCE

INSTRUCTIONS FOR TEES, CROSSES, AND TEST PORT TEES

Tees & Crosses:

These are described as fittings with entirely identical threads (3 for tees, 4 for crosses). They are all the same gender and thread type. For example, a Male BSPP Tee is a fitting with 3 identical male BSPP threads, while a Female BSPP Cross has 4 identical female BSPP threads.

Branch Tees & Run Tees:

Branch Tees are 3 ended fittings with the common threads located straight across from one another, while Run Tees have the common threads located at 90° from each other. The rules for listing both branch and run tees are the same: if there is one thread type only, the part is usually listed by the odd thread gender first. For example, a Female JIS Run Tee has 2 male threads and one female (all JIS). Alternatively, if there are 2 thread types, the common threads are listed first, then the odd end (with gender reference). For example, a Male JIC X Male BSPT Run Tee has 2 male JIC threads and one male BSPT thread.

Test Port Tees:

Test port tees are not conversion adapters, rather they are meant to be placed in line with your current hydraulic system allowing for the implementation of a pressure gauge, for example. They usually consist of a male and female thread (swivel) that are always identical thread types. Test port thread types and sizes vary from fitting to fitting but are always female.

TEES, CROSSES, TEST PORT TEES

DESCRIPTIONS	STEEL		STAINLESS		BRASS		BLACK PIPE	
	SERIES	PAGE	SERIES	PAGE	SERIES	PAGE	SERIES	PAGE
BRASS COMPRESSION X BSPT MALE RUN TEE					171	87		
BRASS COMPRESSION X BSPT MALE BRANCH TEE					172	87		
BRASS POLYTUBE COMPRESSION X BSPT MALE RUN TEE					271	88		
BRASS POLYTUBE COMPRESSION X BSPT MALE BRANCH TEE					272	88		
BRASS PUSH TO CONNECT X BSPT MALE RUN TEE					571	89		
BRASS PUSH TO CONNECT X BSPT MALE BRANCH TEE					572	89		
BRASS PUSH TO CONNECT X BSPT MALE BRANCH "Y"					575	89		

TEES, CROSSES, TEST PORT TEES

DESCRIPTIONS	STEEL		STAINLESS		BRASS		BLACK PIPE	
	SERIES	PAGE	SERIES	PAGE	SERIES	PAGE	SERIES	PAGE
BSPP MALE TEE	9080	62						
BSPP MALE CROSS	9096	63						
BSPP MALE RUN TEE	9095	63						
BSPP MALE ADJ. RUN TEE	9151	63						
BSPP MALE ADJ. BRANCH TEE	9152	63						
BSPP MALE X BSPP MALE TEST PORT TEE	9000TP	47						
BSPP TEST PORT TEE	9015TP	51						
BSPP MALE X ORB MALE ADJ. RUN TEE	9078	62						
BSPP MALE X ORB MALE ADJ. BRANCH TEE	9079	62						
BSPP FEMALE SOLID TEE	9086	62			8085	92	B4444	95
BSPP FEMALE SWIVEL TEE	9085	62						
BSPP FEMALE SOLID CROSS	9097	63			8097	92		
BSPP FEMALE SWIVEL RUN TEE	9090	63						
BSPP FEMALE SWIVEL BRANCH TEE	9087	62						
BSP FEMALE SOLID X BSPT MALE RUN TEE					8095	92		
BSP FEMALE SOLID X BSPT MALE BRANCH TEE					8093	92		
BSPT MALE TEE					8080	92		
DIN MALE TEE	5080	37	SS5080	78				
DIN MALE CROSS	5096	38						
DIN MALE X BSPP MALE ADJ. RUN TEE	5158	38						
DIN MALE X BSPP MALE ADJ. BRANCH TEE	5159	38						
DIN MALE X METRIC MALE ADJ. RUN TEE	5168	38						
DIN MALE X METRIC MALE ADJ. BRANCH TEE	5169	39						
DIN MALE X ORB MALE ADJ. RUN TEE	5178	39						
DIN MALE X ORB MALE ADJ. BRANCH TEE	5179	39						
DIN FEMALE SWIVEL RUN TEE	5390	43	SS5390	80				
DIN FEMALE SWIVEL BRANCH TEE	5387	43	SS5387	80				

TUTORIALS

FEATURED

STEEL

STAINLESS STEEL

BRASS

MEALLEABLE IRON

QUICK REFERENCE

ABOUT

QUICK REFERENCE

TEES, CROSSES, TEST PORT TEES

DESCRIPTIONS	STEEL		STAINLESS		BRASS		BLACK PIPE	
	SERIES	PAGE	SERIES	PAGE	SERIES	PAGE	SERIES	PAGE
JIC MALE X BSPP MALE ADJ. RUN TEE	9158	63						
JIC MALE X BSPP MALE ADJ. BRANCH TEE	9159	64						
JIC MALE X BSPT MALE RUN TEE	9163	64						
JIC MALE X BSPT MALE BRANCH TEE	9164	64						
JIC MALE X METRIC MALE ADJ. RUN TEE	9168	64						
JIC MALE X METRIC MALE ADJ. BRANCH TEE	9169	64						
JIC FEMALE SWIVEL TEE	9555	71						
JIC FEMALE RUN TEE	4757	44						
JIC FEMALE BRANCH TEE	4775	44						
JIC TEST PORT TEE	9020TP	52						
JIS FEMALE RUN TEE	9291	68						
JIS TEST PORT TEE	9293TP	68						
KOMATSU FEMALE RUN TEE	9391	69						
KOMATSU TEST PORT TEE	9634TP	72						
ORFS MALE X BSPP MALE ADJ. RUN TEE	6158	45						
ORFS MALE X BSPP MALE ADJ. BRANCH TEE	6159	46						
ORFS MALE X METRIC MALE ADJ. RUN TEE	6168	46						
ORFS MALE X METRIC MALE ADJ. BRANCH TEE	6169	46						

COMPONENTS (BOLTS, NUTS, O-RINGS, RINGS, SEALS, SEATS, WASHERS)

DESCRIPTIONS	STEEL		STAINLESS		BRASS		BLACK PIPE	
	SERIES	PAGE	SERIES	PAGE	SERIES	PAGE	SERIES	PAGE
BSPP BANJO BOLT	3002	29						
BSPP DOUBLE BANJO BOLT	3002DB	29						
METRIC BANJO BOLT	3068	29						
METRIC DOUBLE BANJO BOLT	3068DB	30						
UNF BANJO BOLT	3048	29						
BSPP BULKHEAD NUT	9041	57	SS9041	84				
DIN TUBE NUT	5201	39	SS5201	78				
DIN TUBE BLANKING PLUG FOR NUT	5204P	40	SS5204P	79				
METRIC BULKHEAD NUT	5041	33						
BSPP O-RING	OR	74						
METRIC O-RING	OR-MM	75						
ORB O-RING	OR SAE	75						
ORFS O-RING	ORFS	75						
BSPP RETAINING RING	RR	75	SSRR	86				
DIN TUBE CUTTING RING	5202	40	SS5202	78				
METRIC RETAINING RING	RR-MM	75						
BSPP ES SEAL	ESB	74						
METRIC ES SEAL	ESM	74						
24° TO GB 37°/74° CONVERSION SEAT	5333	42						
24° TO GB FACE SEAL CONVERSION SEAT	5333FF	42						
30° TO GB 37°/74° CONVERSION SEAT	9333	69						
30° TO GB FACE SEAL CONVERSION SEAT	9333FF	69						
HIAB CONVERSION SEAT	9777	73						
JIS CONVERSION SEAT	9999	74						
BSPP BONDED WASHER	9500	70	SS9500	85				
BSPP BONDED WASHER (NON SELF CENTERING)	9500NSC	70						
BSPP BONDED WASHER VITON	9500-V	70	SS9500-V	85				
BSPP COPPER WASHER BANJO	3500	30						
METRIC BONDED WASHER	9500MM	70	SS9500MM	85				
METRIC BONDED WASHER (NON SELF CENTERING)	9500MM-NSC	70						
METRIC BONDED WASHER VITON	9500MM-V	70	SS9500MM-V	86				
METRIC COPPER WASHER BANJO	3500MM	30						

ABOUT

Adaptall was founded in 1985 with the intent to supply the North American hose and fitting Distributor market with high quality Metric and British adapters, in steel, stainless steel and brass.

We have grown to include multiple locations in Canada and the USA, including a CNC manufacturing facility, in order to meet the many unique needs of our valued customers.

We pride ourselves on providing industry leading customer service, and the largest inventory of Metric and British Adapters in North America via same day shipping.

TERMS & CONDITIONS

- Prices subject to change without prior notice.
- F.O.B. our plant.
- All taxes and government surcharges are extra where applicable.
- No returns without prior written consent (see Returns Policy).
- All sales to U.S. customers are payable in USD funds.
- All sales to Canadian customers are payable in CAD funds.
- All sales to International customers are payable in USD funds.

WARRANTY

Adaptall warrants its products to be free of defects in material and workmanship. No warranty of merchantability or other warranty, express or implied, is made. Liability for and the exclusive remedy for defective materials or workmanship is limited to replacement or repair of defective products returned within 60 days after receipt. No allowance will be made for repairs performed by the purchaser or on their order. Adaptall is not liable for consequential or other damages or any expense incurred through the use of its products. All design and dimensional data are subject to change without notice. Working pressures, torque settings, corrosion data and other technical information have been prepared from actual test results and other data considered to be reliable. However, no responsibility can be assumed for the accuracy of this information under varied field conditions and should be considered as a recommendation only and not a guarantee.

CERTIFICATIONS

- ISO 9001:2015
- C-TPAT & PIP

COMPLIANCES

- Buy America Act / American Reinvestment and Recovery Act of 2009 (ARRA)
- Proposition 65 (California)
- RoHS 2 & 3

FITTING STANDARDS

- BSPP (ISO: 1179-1, 1179-2, 1179-3, 8434-6)
- BSPT (ISO 7)
- DIN TUBE (DIN: 2353, 3861, ISO 8434-1)
- JIC (ISO 8434-2, SAE J514)
- JIS (JIS B 0202)
- METRIC (DIN 7647, GB 37/74, GB FFace, ISO: 6149, 9974-1, 9974-2, 9974-4)
- NPT (ANSI B1.20.3)
- ORB (ISO 11926, SAE J1926)
- ORFS (ISO 8434-3, SAE J1453)

ZINC PLATING SPECIFICATIONS (STEEL PARTS)

- Plating in accordance with ASTM B633-15
- Type Fe/Zn 8 Class V with clear coat
- Electro-Deposited Zinc coating with minimum thickness of 8 microns (0.0003")
- Compliant: OSHA (USA), CCOHS (Canada) and RoHS (European Union)
- Zinc coating does NOT contain hexavalent chromate

MATERIAL SPECIFICATIONS

Brass

- North American products: C36000
- European products: OT UNI EN 12164/5 CW 614/7N

Carbon steel

- European & North American products: C12L14
- Asian products: GB/T 699-2015

Stainless steel

- SS DIN tube fittings: SS316
- Standard SS fittings: SS316

O-rings

- Nitrile (NBR) 70-90 durometer
- Viton 75-90 durometer

TUTORIALS

FEATURED

STEEL

STAINLESS STEEL

BRASS

MEALLEABLE IRON

QUICK REFERENCE

ABOUT

TORQUE SPECIFICATION CHARTS

BSPP Port – Torque Settings

			Retaining Ring & O-Ring		ED/ES Seal		Bonded Washer	Cutting Face	Banjo	
	Dash Size	Inch Thread Size-TPI	Straight (Nm)	Adjustable (Nm)	Straight (Nm)	Plugs (Nm)	Straight (Nm)	Straight (Nm)	With Copper Washers	With Soft Seals
Light Series (L)	02	1/8-28	18	18	18	13	9	18	18	18
	04	1/4-19	35	35	35	30	35	35	45	40
	06	3/8-19	70	70	70	60	45	70	70	65
	08	1/2-14	90	110	90	80	65	100	120	90
	12	3/4-14	180	180	180	140	90	180	230	125
	16	1-11.5	310	310	310	200	150	330	320	
	20	1-1/4-11.5	450	450	450	400	240	540	540	
	24	1-1/2-11.5	540	540	540	450	290	630	700	
Heavy Series (S)	02	1/8-28		25						
	04	1/4-19		55	40		35	55	45	40
	06	3/8-19		90	80		45	90	70	65
	08	1/2-14		110	115		65	130	120	90
	12	3/4-14		115	180		90	270	230	125
	16	1-11.5		420	310		150	340	320	
	20	1-1/4-11.5		550	450		240	540	540	
	24	1-1/2-11.5		600	540		290	700	700	

DIN DKO Swivel - Torque Settings

	Thread Size Mm	Tube Size	DIN DKO Swivel (Nm)
L Light Duty	12	L06	16
	14	L08	16
	16	L10	26
	18	L12	37
	22	L15	47
	26	L18	89
	30	L22	116
	36	L28	137
S Heavy Duty	45	L35	226
	52	L42	347
	14	S06	26
	16	S08	42
	18	S10	53
	20	S12	63
	22	S14	79
	24	S16	84
30	S20	126	
36	S25	179	
42	S30	263	
52	S38	368	

Metric Port – Torque Settings

			Retaining Ring & O-Ring		ED/ES Seal		ISO 6149	Bonded Washer	Cutting Face	Banjo	
	Thread Size mm	Straight (Nm)	Adjustable (Nm)	Straight (Nm)	Plugs (Nm)	Straight & Adjustable (Nm)	Straight (Nm)	Straight (Nm)	With Copper Washers	With Soft Seals	
Light Series (L)	12	25	25	25	25	25	20	30	45	35	
	14	40	40	45	35	35	35	45	55	50	
	16	55	55	55	55	40	45	65	80	60	
	18	70	70	70	65	45	55	80	100	80	
	22	90	90	125	90	60	65	140	140	120	
	27	180	180	180	135	100	90	190	320	130	
	33	310	310	310	225	160	150	340	360		
	42	450	450	450	360	210	240	500	540		
Heavy Series (S)	48	540	540	540	360	260	290	630	700		
	12	35	35	35		35	20	35	45	35	
	14	55	55	45		45	35	55	55	50	
	16	70	70	70		55	45	70	80	60	
	18	90	90	90		70	55	110	100	80	
	20	125	125	125	80	80	55	150	125	110	
	22	135	135	135		100	65	170	135	120	
	27	180	180	180		170	90	270	320	135	
33	310	310	310		310	150	410	360			
42	450	450	450		330	240	540	540			
48	540	540	540		420	290	700	700			

BSPP Swivel - Torque Settings

Dash Thread Size	Inch Thread Size-Tpi	BSPP Swivel (Nm)
04	1/4-19	20
06	3/8-19	35
08	1/2-14	60
10	5/8-14	70
12	3/4-14	115
16	1-11	140
20	1-1/4-11	210
24	1-1/2-11	290

BSPT T.F.F.T Values

BSPT Dash Size	Inch Thread Size-TPI	Turns From Finger Tight (T.F.F.T)
02	1/8-28	2 - 3
04	1/4-19	2 - 3
06	3/8-19	2 - 3
08	1/2-14	2 - 3
10	5/8-14	2 - 3
12	3/4-14	2 - 3
16	1-11	1.5 - 2.5
20	1-1/4-11	1.5 - 2.5
24	1-1/2-11	1.5 - 2.5

Please note:

- All torque values are intended for steel fittings.
- For Brass fittings and adapters use 65 % of the torque values.
- For Stainless steel fittings and adapters, use 5% higher value than listed and lubricate threads.



ISO 9001
REGISTERED



 1-800-463-8134

 1-800-994-5699

 SALES@ADAPTALL.COM

 WWW.ADAPTALL.COM

 LINKEDIN.COM/COMPANY/ADAPTALL

 @ADAPTALL



HOUSTON DC
5246 N SAM HOUSTON PKWY E
HOUSTON, TX
77032

USA HQ & DC
9047 DUTTON DR.
TWINSBURG, OH
44087

CANADA HQ & DC
150 BRUNEL RD.
MISSISSAUGA, ON
L4Z 1T5