

# Index

Page

## Reservoirs



Intro/Custom Reservoirs	2
Hydraulic Reservoirs	3
J.I.C.	4
Large J.I.C.	5
"L" Shaped	6
Containment Trays	7
WCE Econoline / Reservoir Stands	8
Vertical Reservoirs	9-11
End Covers, Self Aligning Cover Bar	12

## End Covers



## Flanges



S.A.E. Adapters	13
Flange Kits	14
Weld Risers	14
4 Bolt Solid Flanges	15

## Motor Mounts



Shock Mounts	16
Motor Dampening Bars	17

## Plugs



Breather Plugs	18
Magnetic Filtration	19

## Sight Levels



Sight Plugs SAE / METRIC / BSP	20
Plastic Prism Sight Plugs / Oil Level Sight Plugs	21
Sight Level Gauge	22
Sight-Temperature Gauge / Fast Mount Kit	23
Electric Sight Level Gauge / Sight Level Gauge	24

## Pressure Gauges



Pressure Gauges	25-26
Gauge Isolator Valves	27
Gauge Panels	28

## Filler Breathers



Filler Breather Assembly Kit	29
Anti-Slosh Filler Breather	30
Side Mount Filler Breathers	31
Air Breathers	32
Valve Breather Caps	33
Filler Breathers – Screw-In Style – Anti-Slosh	33

## Filters



Return Line Filters	34-37
Suction Line Filters / Tank-Mounted Strainers	38

## Couplings



Flexible Drive Couplings	39-42
Pump Motor Mounts	43-48

## Ball Valves



Ball Valves	49-51
-------------	-------

## Manifolds



Manifolds	52-55
-----------	-------

## Formulas



Fluid Power Formulas	56
----------------------	----

## Custom Design Reservoirs



### HYDRO-CRAFT®, WHERE QUALITY RESERVOIRS ARE THE STANDARD

Hydro-Craft has been the leading manufacturer of hydraulic reservoirs and accessories for over 59 years. Excellent service and high quality have been a part of the Hydro-Craft package from the start, meeting the hydraulic needs of many diverse industries and applications.

Hydro-Craft offers a complete line of standard reservoirs, designed for most popular applications. We are the leader in manufacturing customized reservoirs. Our advanced engineering department has designed thousands of custom reservoirs to customer specifications and our expert manufacturing and production department has produced them all at a cost-effective rate in any quantity. We may already have a nonstandard design on file that will fit your application, or we can modify an existing standard design, saving you time and money. We will work with you to develop the best design for your application and situation.

Our commitment to quality, our on-time performance record, and our experienced staff all contribute to the reputation Hydro-Craft has built. A reputation for excellence that our competitors can't match. We are committed to a continuous process of training for our staff and updating our manufacturing equipment and processes, so that we maintain our reputation for quality products. You can count on that.

Whether you require a standard or customized reservoir, contact Hydro-Craft for a quality product at a reasonable cost.

At Hydro-Craft, quality reservoirs, whether they are stock or custom, are the standard!



## "Industry Accepted" Hydraulic Reservoirs

### IMPORTANT FEATURES

- Hydro-Craft<sup>®</sup> Reservoirs meet or exceed all J.I.C. and ASLE Standards
- Scale-free welding process is used
- All Hydro-Craft Reservoirs are carefully fabricated from hot rolled steel plate and sheet, pickled and oiled, which eliminates the need for sand blasting and subsequent residue. Stainless steel also available.
- Fixed baffle properly slotted for correct oil circulation
- Single bolt end caps sized for maximum cleanout opening
- 3/4 NPT drain standard on one end cover
- Hydro-Craft Sight Level Gauge is plated and has extra large sight area with nonbreakable 2X magnifier
- Combination oil level and temperature gauge is standard. Temperature gauge features readings in Centigrade and Fahrenheit.
- Hydro-Craft Filler Breather Assembly is plated and guarded. It has a non-corrosive nylon strainer. Ten times the amount of air flow as comparable units now available.
- Four 2-1/4" diameter lift holes
- "L" Shaped Reservoirs come equipped with a full length piano hinge for opening lid and secure T-handle closure

### AVAILABLE OPTIONS:

- Coupling Guards
- Additional Sight Gauge
- Special duty and high temperature level gauge
- Additional Filler Breather
- Pipe Couplings – Whole or Half, SAE or NPT
- Down Lines
- Interior Paint
- Extra Drain
- Drip Pans, Stands, & Overhead Stands
- Lift Rings
- Removable Baffle

NOTE: These are non-pressurized reservoirs



Photos show just a few of the hundreds of standard and custom reservoirs fabricated by Hydro-Craft<sup>®</sup> each year.

# J.I.C. Reservoir Dimensional Data

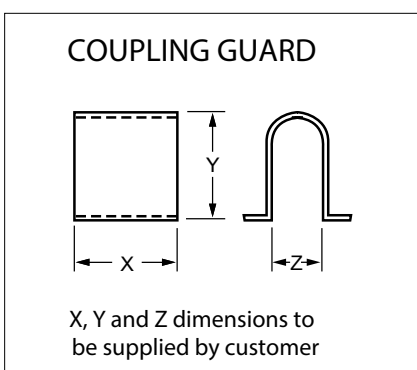
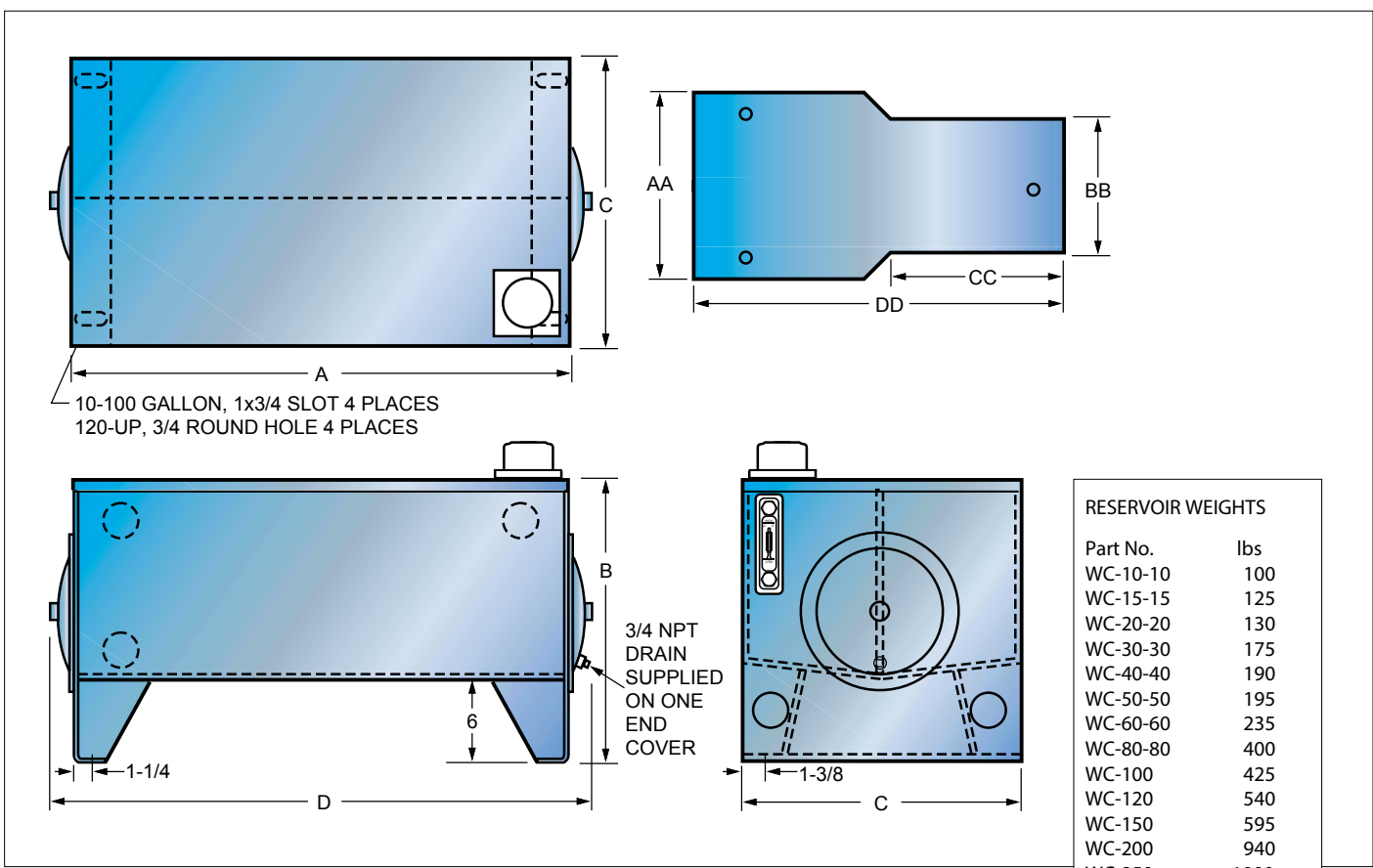

## J.I.C. RESERVOIR SPECIFICATIONS

PART NO.	WC-10-10	WC-15-15	WC-20-20	WC-30-30	WC-40-40	WC-50-50	WC-60-60	WC-80-80	WC-100	WC-120	WC-150	WC-200	WC-250	WC-300
GALLON	10	15	20	30	40	50	60	80	100	120	150	200	250	300
A (L)	22	26	30	36	36	36	48	60	60	60	60	72	72	72
B (H)	20	20	20	20	22	23	21	21-1/4	24-1/4	25-5/8	30-5/8	29-3/8	32-3/8	36-5/8
C (W)	18	18	18	24	24	24	27	27	30	30	30	36	36	36
D	26	30	34	40-3/4	40-3/4	40-3/4	52-3/4	64-3/4	64-3/4	66	66	78	78	78
END COVER	12	12	12	14	14	14	14	14	14	14	18	18	18	18
ENDS	7 ga.	7 ga.	7 ga.	7 ga.	7 ga.	7 ga.	7 ga.	7 ga.	7 ga.	3/8	3/8	3/8	3/8	3/8
TOP	7 ga.	7 ga.	7 ga.	7 ga.	7 ga.	7 ga.	7 ga.	3/8	3/8	3/8	3/8	3/8	3/8	3/8
SIDES	12 ga.	12 ga.	12 ga.	12 ga.	12 ga.	12 ga.	12 ga.	12 ga.	12 ga.	12 ga.	12 ga.	7 ga.	7 ga.	7 ga.
BOTTOM	12 ga.	12 ga.	12 ga.	12 ga.	12 ga.	12 ga.	12 ga.	12 ga.	12 ga.	12 ga.	12 ga.	7 ga.	7 ga.	7 ga.

All dimensions are approximate in inches

## Large J.I.C. Reservoir Dimensional Data

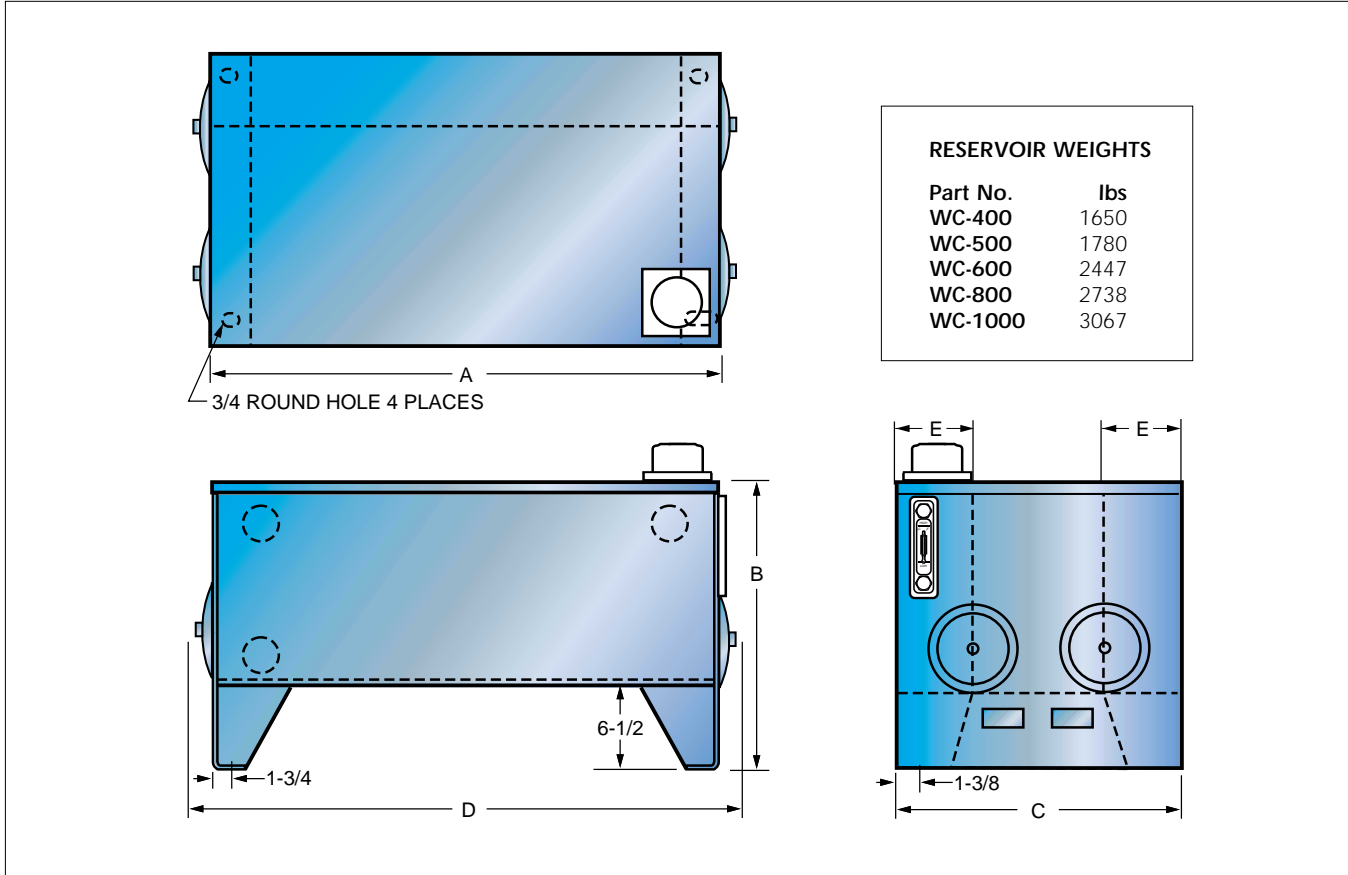

### LARGE J.I.C. RESERVOIR SPECIFICATIONS

PART NO.	WC-400	WC-500	WC-600	WC-800	WC-1000
<b>GALLON</b>	400	500	600	800	1000
<b>A (L)</b>	72	72	96	96	96
<b>B (H)</b>	37	43	36	44	53
<b>C (W)</b>	48	48	60	60	60
<b>D</b>	78	78	102	102	102
<b>E</b>	13	13	17	17	17
<b>END COVER</b>	18	18	18	18	18
<b>ENDS</b>	1/2	1/2	1/2	1/2	1/2
<b>TOP</b>	1/2	1/2	1/2	1/2	1/2
<b>SIDES</b>	7 Gauge	7 Gauge	7 Gauge	7 Gauge	7 Gauge
<b>BOTTOM</b>	7 Gauge	7 Gauge	1/4	1/4	1/4

# "L" Shaped Reservoir Dimensional Data

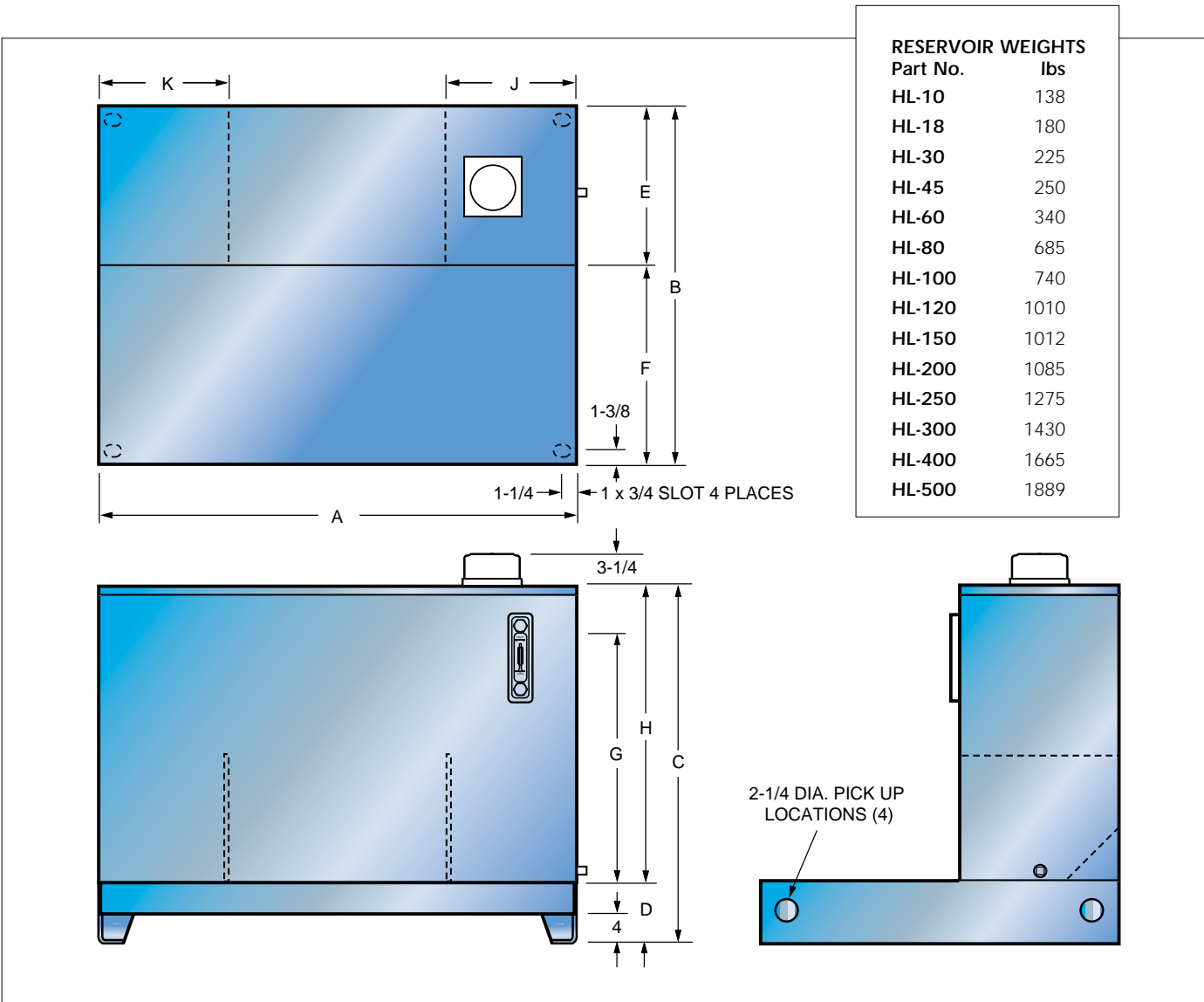

## "L" SHAPED RESERVOIR SPECIFICATIONS

PART NO.	HL-10	HL-18	HL-30	HL-45	HL-60	HL-80	HL-100	HL-120	HL-150	HL-200	HL-250	HL-300	HL-400	HL-500
GALLON	10	18	30	45	60	80	100	120	150	200	250	300	400	500
A (L)	24	30	36	40	48	66	60	72	72	72	72	72	72	72
B (W)	25	30	30	30	36	36	48	48	48	48	48	48	60	60
C (H)	23	25	30	31	36	36	36	36	36	42	48	54	54	66
D	6-3/16	6-3/16	6-3/16	6-3/16	6-3/16	6-1/2	6-1/2	6-1/2	6-1/2	6-1/2	6-1/2	6-1/2	6-1/2	6-1/2
E	12-1/4	13-1/4	14-1/4	14-1/4	16-1/4	16-1/4	19-1/2	22-1/2	24-1/2	24-1/2	24-1/2	24-1/2	30	30
F	12-3/4	16-3/4	15-3/4	15-3/4	19-3/4	19-3/4	28-1/2	25-1/2	23-1/2	23-1/2	23-1/2	23-1/2	30	30
G	10	12	17	18	23	23	23	23	23	29	35	41	43	54
H	17	19	24	25	30	30	30	30	30	36	42	48	48	60
J	12	15	18	20	24	22	20	24	24	24	24	24	24	24
K	—	—	—	—	—	22	20	24	24	24	24	24	24	24

All dimensions are approximate in inches



# Containment Trays — Drip Pans and Stands

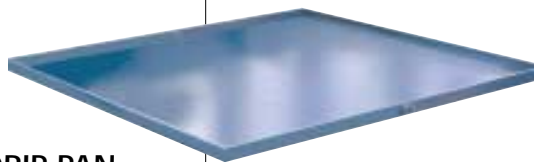
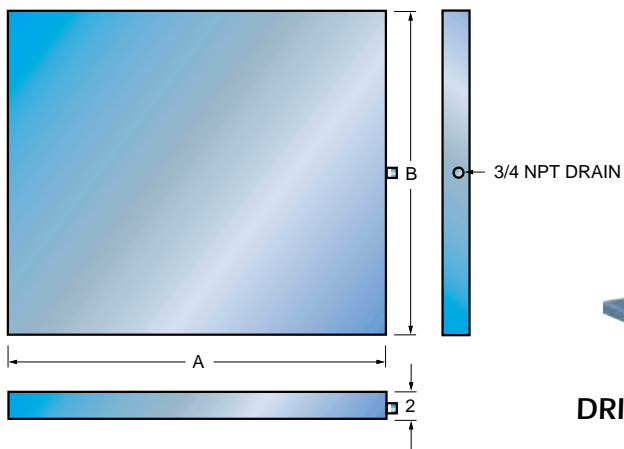

DRIP PAN

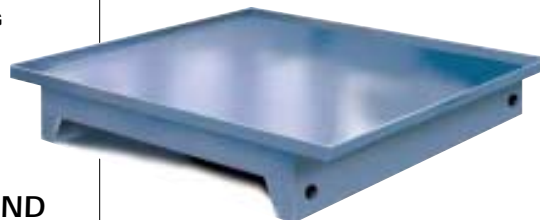
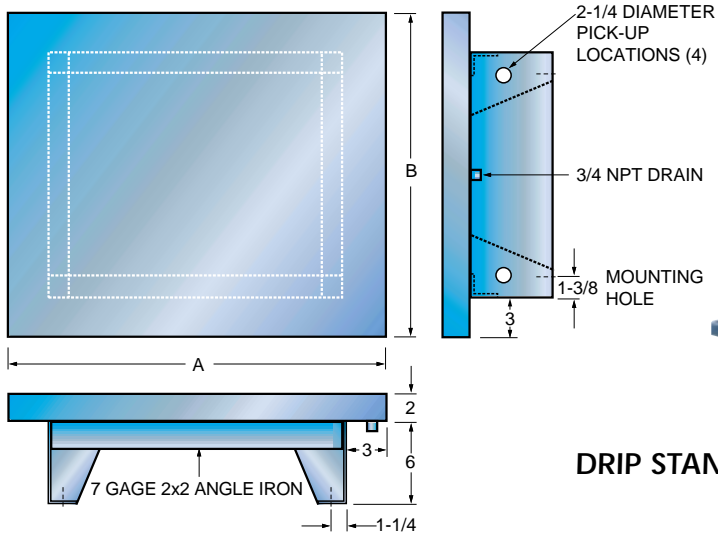

DRIP STAND

## DRIP PANS AND STANDS

DRIP PAN	WC-DP-10	WC-DP-15	WC-DP-20	WC-DP-30	WC-DP-60	WC-DP-80	WC-DP-120	WC-DP-200
				WC-DP-40		WC-DP-100	WC-DP-150	WC-DP-250
				WC-DP-50				WC-DP-300
DRIP STAND	WC-DS-10	WC-DS-15	WC-DS-20	WC-DS-30	WC-DS-60	WC-DS-80	WC-DS-120	WC-DS-200
				WC-DS-40		WC-DS-100	WC-DS-150	WC-DS-250
				WC-DS-50				WC-DS-300
A (LENGTH)	28	32	36	42	54	66	66	78
B (WIDTH)	24	24	24	30	33	33	36	42

DRIP PAN	HL-DP-10	HL-DP-18	HL-DP-30	HL-DP-45	HL-DP-60	HL-DP-80	HL-DP-100	HL-DP-120
								HL-DP-150
								HL-DP-200
DRIP STAND	HL-DS-10	HL-DS-18	HL-DS-30	HL-DS-45	HL-DS-60	HL-DS-80	HL-DS-100	HL-DS-120
								HL-DS-150
								HL-DS-200
A (LENGTH)	30	36	42	46	54	72	66	78
B (WIDTH)	31	36	36	36	42	42	54	54

All dimensions are approximate in inches

	PART NO.	WEIGHT (lbs)
	WCE-10	90
	WCE-15	106
	WCE-20	115
	WCE-30	146
	WCE-40	156
	WCE-50	162
	WCE-60	214
	WCE-80	252
	WCE-100	302

(For dimensions, see A, B, C and D on page 4).

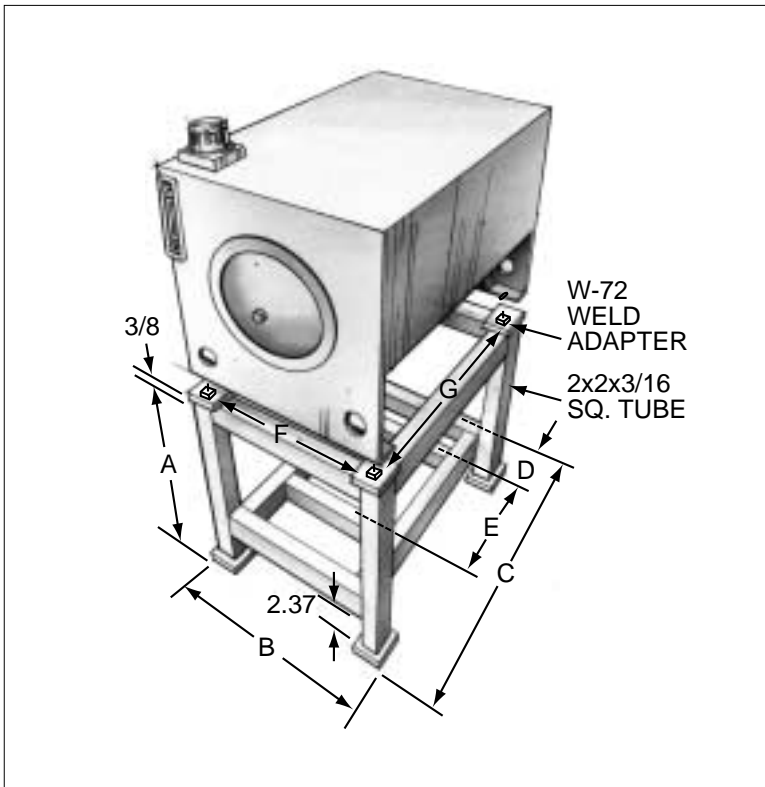

## SPECIFICATIONS

PART NO.	WCS-10	WCS-15	WCS-20	WCS-30	WCS-40	WCS-50	WCS-60	WCS-80	WCS-100	WCS-120	WCS-150	WCS-200
A	24	24	24	24	24	24	32	32	32	32	32	32
B	18	18	18	24	24	24	27	27	27	30	30	36
C	22	26	30	36	36	36	48	60	60	60	60	72
D	Customer to supply dimensions											
E	Customer to supply dimensions											
F	12	12	12	18	18	18	21	21	21	24	24	30
G	16	20	24	30	30	30	42	54	54	54	54	66

All dimensions are approximate in inches

## The WCE Series Econoline Reservoir

...Quality Reservoirs at up to 17% less than our Standard Line.

These reservoirs are built with the same quality steel and attention to construction as all Hydro-Craft® reservoirs.

The WCE series reservoir is identical to our WC series with the following exceptions:

### WCE-10 thru WCE-50

10 ga. ends and top, end cover on one end only.

### WCE-60, WCE-80, WCE-100

7 ga. ends, 10 ga. top, end cover on both ends.

## WCS Elevated Reservoir Stands

- Hydraulic reservoir stands for mounting standard J.I.C. type reservoirs over the pump and motor
- Provides a positive feed to the pump
- May be stacked for greater floor space saving. Standard units available for Hydro-Craft J.I.C. type reservoirs from 10 to 300 gallon capacity. Industry proven design
- Easy reservoir mounting
- Motor/pump mounting plate supports located per your requirements
- Drip pans available
- Custom frameworks available



# Vertical Reservoirs

## EACH NON-J.I.C. VERTICAL RESERVOIR INCLUDES:

- (1) Oil level with temperature gauge
- (4) Cover mounting bolts
- Buna-N seal for cover plate
- 3/4" NPT drain
- Steel construction with customer's choice of top
- Primer-painted exteriors
- Reservoir interiors coated with rust-inhibiting oil

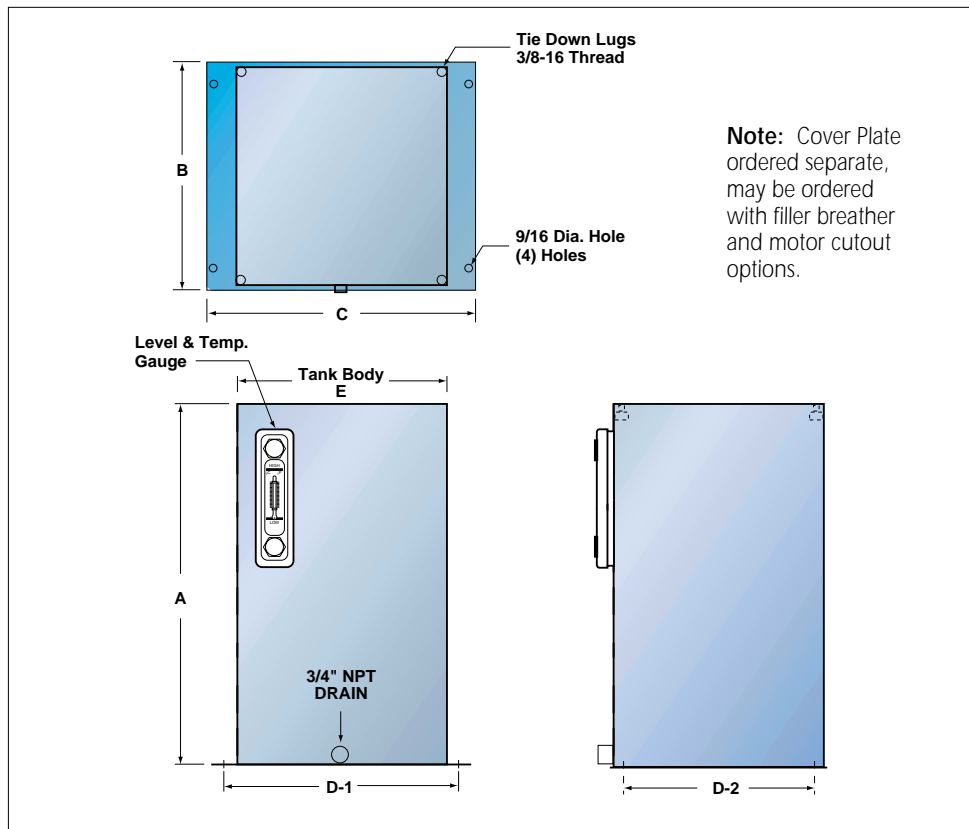

## SPECIFICATIONS

PART NO.	WEIGHT						
	(lbs.)	A	B	C	D-1	D-2	E
HV-5 (5 gallon)	22	10	12-1/2	14-1/2	13-1/2	10	12
HV-10-A (10 gallon)	38	20	12-1/2	14-1/2	13-1/2	10	12
HV-10-B (10 gallon)	36	12	16-1/2	19	17-1/2	14	16
HV-20 (20 gallon)	64	24	16-1/2	19	17-1/2	14	16
HV-30 (30 gallon)	86	36	16-1/2	19	17-1/2	14	16

**Note:** All dimensions are approximate in inches.

# Cover Plates FOR VERTICAL RESERVOIRS

HV-5 and HV-10-A

## ORDERING INFORMATION

Hydro-Craft® Non-JIC Vertical Reservoirs allow you to choose the cover plate style you need. Reservoir and Cover Plate must be ordered as separate items.

**Example:** Part number HVT-A-2 is cover with filler breather cutout and fits on reservoirs HV-5 or HV-10-A.

**Note:** Filler Breathers are included with Cover Plates A-2, A-3, and A-4

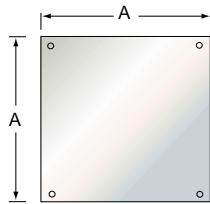

**HVT-A-1**  
Blank Cover

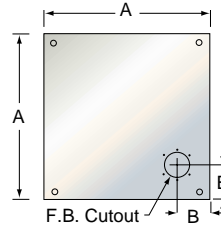

**HVT-A-2**  
Cover with  
Filler Breather  
Cutout

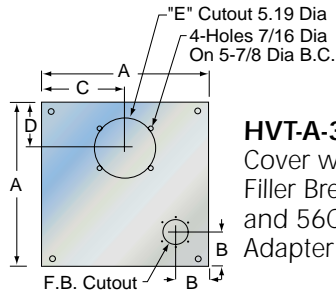

**HVT-A-3**  
Cover with  
Filler Breather  
and 56C/145TC  
Adapter Cutouts

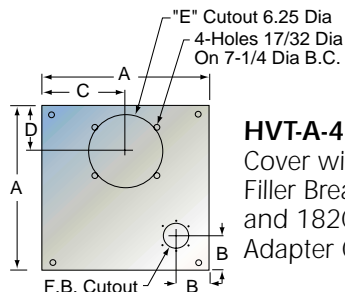

**HVT-A-4**  
Cover with  
Filler Breather  
and 182C/256TC  
Adapter Cutouts

## SPECIFICATIONS

RESERVOIR PART NO.	STANDARD DIMENSIONS FOR VERTICAL TOPS					COVER PART NO.	COVER PLATE WEIGHT (LBS)
	A (SQ)	B	C	D	E (ADAPTER CUTOUT)		
HV-5	12-1/2"	2-1/2"	6-1/4"	5"		<b>HVT-A-1</b>	10.75
HV-10-A					56C/145TC	<b>HVT-A-3</b>	9
					182C/256TC	<b>HVT-A-4</b>	8.25

# Cover Plates FOR VERTICAL RESERVOIRS

HV-10-B, HV-20 and HV-30

## ORDERING INFORMATION

Hydro-Craft® Non-JIC Vertical Reservoirs allow you to choose the cover plate style you need. Reservoir and Cover Plate must be ordered as separate items.

**Example:** Part number HVT-B-3 is cover with filler breather and 56C/145TC adapter cutouts and fits on reservoirs HV-10-B, HV-20 or HV-30.

**Note:** Filler Breathers are included with Cover Plates B-2, B-3, B-4, and B-5

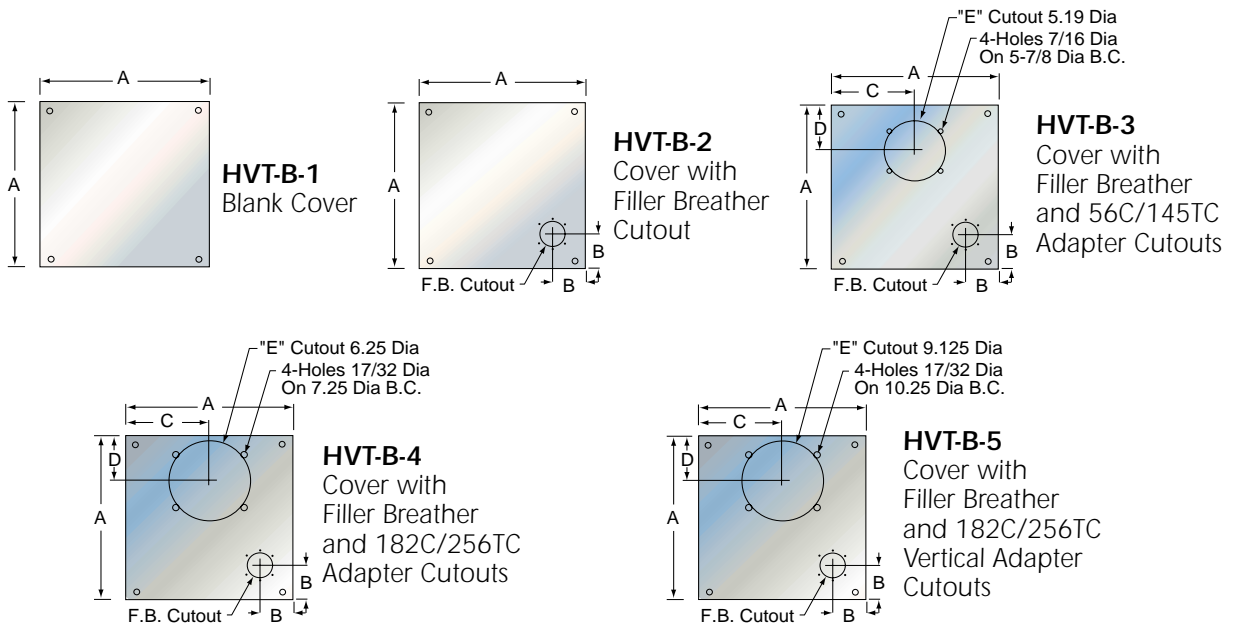

## SPECIFICATIONS

RESERVOIR PART NO.	STANDARD DIMENSIONS FOR VERTICAL TOPS					COVER PART NO.	COVER PLATE WEIGHT (LBS)
	A (SQ)	B	C	D	E (ADAPTER CUTOUT)		
HV-10-B	16-1/2"	2-1/2"	8-1/4"	5"		<b>HVT-B-1</b>	18.75
HV-20						<b>HVT-B-2</b>	18.50
HV-30					56C/145TC	<b>HVT-B-3</b>	17
				182C/256TC	<b>HVT-B-4</b>	16.25	
			6-1/4"	182C//256TC VERTICAL	<b>HVT-B-5</b>	13.75	

## End Covers

Hydro-Craft® end covers for replacement or retrofit are available in 12-, 14-, and 18-inch diameters. Available in steel and stainless steel. Steel end covers are zinc plated for corrosion protection. All end covers are available with optional drain. All have a unique formed on Buna-N lip seal which has excellent resistance to cutting and abrasion, and is compatible with all standard hydraulic fluids. Replacement seals, if required, are readily available.

The end cover is attached to the reservoir by the unique Hydro-Craft baffle adapter. The design of the HC-BA-10 allows it to be attached to the baffle with press pins or standard bolts, assuring a tight, shockproof installation, and eliminating the need for welding and subsequent weld splatter, warping and stressing of the baffle. The Hydro-Craft baffle adapter is also available in 304 stainless steel.

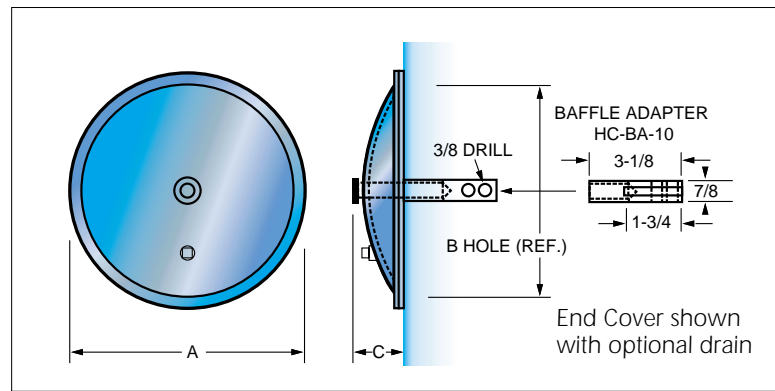

### SPECIFICATIONS

PART NO.	A	B	C	MATERIAL	WEIGHT
HC-EC-12	11-7/8	10	1-5/8	7 GA	6-1/4
HC-EC-14	14	12	2	7 GA	8
HC-EC-18	18	16	2-5/8	7 GA	14-1/2
HC-EC-12SS	12	10	1-5/8	12 GA	4
HC-EC-14SS	14-5/8	12	2-1/8	7 GA	9-3/4
HC-EC-18SS	18	16	2-5/8	.194	8

**NOTE:** Add E or V to End Cover part number for EP Seal or Viton.  
Add D at end of part number for drain.  
The Buna-N Lip Seal is the standard seal used on end covers.

### END COVER REPLACEMENT SEALS

PART NO.	DESCRIPTION	COVER SIZE
HC-LIP-S-12-E	EP Seal Kit	12
HC-LIP-S-14-E	EP Seal Kit	14
HC-LIP-S-18-E	EP Seal Kit	18
HC-LIP-S-12	Buna-N Lip Seal	12
HC-LIP-S-14	Buna-N Lip Seal	14
HC-LIP-S-18	Buna-N Lip Seal	18
HC-LIP-S-12-V	Viton Lip Seal	12
HC-LIP-S-14-V	Viton Lip Seal	14
HC-LIP-S-18-V	Viton Lip Seal	18

### SELF ALIGNING COVER BAR

The Hydro-Craft self aligning cover bar is available for 12- and 14-inch end covers. Installed by placing a bolt through the end cover and turning a few threads into the cover bar, it can then be angled through the reservoir access hole. Allowing the cover bar to rest on the bottom of the reservoir, it will automatically align itself to the proper height to be torqued firmly into place. This durable self aligning cover bar is fabricated from 3/8-inch hot rolled, pickled and oiled steel plate. More than ample torque can be applied to insure a perfect seal on the reservoir end cover.

### SPECIFICATIONS

PART NO.	END COVER	HOLE HOLE DIA.	DIMENSIONS		
			A	B	C
HC-X-BAR-12	12	10	12	6	4-3/8
HC-X-BAR-14	14	12	14-1/4	7-1/8	5-3/8

### OPTIONS

PART NO.	DESCRIPTION
HC-BA-10*	Baffle Adapter
HC-BA-P*	Baffle Adapter Pin
HC-EC-CW	Crush Washer
HC-EC-CB-*	End Cover Bolt
	DIMENSION A
HC-C-BAR-12	12
HC-C-BAR-14	14
HC-C-BAR-18	18

\*Available in stainless steel

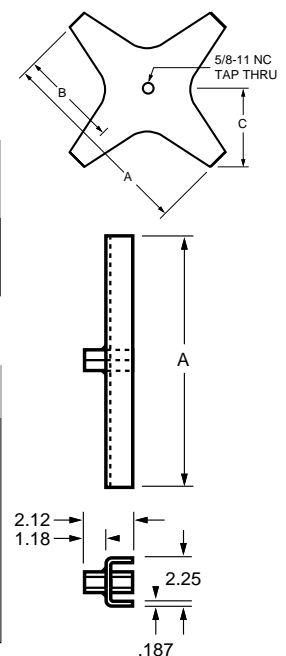

# S.A.E. Adapters

## 3/8 INCH TO 2 INCH

Hydro-Craft® S.A.E. Weld Boss Flanges and Weld Couplings are precision manufactured from 12L14 Leadloy steel. They will save time and labor when mounting S.A.E. components. Used as a downline coupling, they eliminate the need for expensive straight-thread downlines...simply attach the S.A.E. component to the topside, and thread an inexpensive pipe nipple to the NPT side in the reservoir. Adapters are shipped unplated but oiled to prevent corrosion.



**WELD COUPLING FEMALE  
S.A.E. TO FEMALE N.P.T.**



**WELD BOSS FEMALE S.A.E.**

WE ARE NOW OFFERING:  
WELD BOSS FLANGES IN BSPP THREADS. ALSO BSPP TO NPT  
AND BSPP TO BSPP FULL COUPLINGS. PLEASE CONTACT US!



### FEMALE S.A.E. TO N.P.T.

PART NO.	FEMALE PIPE	FEMALE S.A.E.	L ±.03	D DIA.	PSI
WCF-6-6	3/8	9/16-18	1.41	7/8	4000
WCF-8-8	1/2	3/4-16	1.72	1-1/8	3000
WCF-12-12	3/4	1-1/16-12	1.98	1-3/8	2500
WCF-16-16	1	1-5/16-12	2.17	1-5/8	2000
WCF-20-20	1-1/4	1-5/8-12	2.25	2-1/8	1150
WCF-24-24	1-1/2	1-7/8-12	2.26	2-1/2	1000
WCF-32-32	2	2-1/2-12	2.41	3	1000

Add "SS" to the end of part number for 316 stainless steel adapters.



### FEMALE S.A.E. BOSS

PART NO.	FEMALE S.A.E.	L ±.03	D DIA.	INSTALLATION HOLE SIZE	PSI
WBF-6	9/16-18	.70	.87	.625	5000
WBF-8	3/4-16	.85	1.1	.875	4500
WBF-10	7/8-14	.96	1.375	1.0	3500
WBF-12	1-1/16-12	.96	1.375	1.0	3500
WBF-14	1-3/16-12	1.1	1.6	1.25	3000
WBF-16	1-5/16-12	1.1	1.6	1.375	3000
WBF-20	1-5/8-12	1.1	2.1	1.75	2500
WBF-24	1-7/8-12	1.1	2.5	2.0	2000
WBF-32	2-1/2-12	1.2	3.0	2.5	1500

Add "SS" to the end of part number for 316 stainless steel adapters.  
SAE to SAE or custom adapters are available, contact Hydro-Craft.

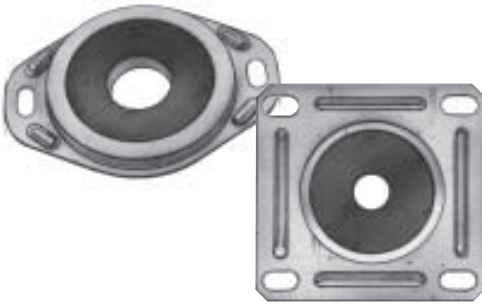

## Flange Kits

Hydro-Craft® flange kits are available for either tube or pipe, Suction Line or Return Line. The Return Line kit consists of: 2 bolts, 1 rubber gasket, 1 metal flange. The Suction Line kit consists of: 4 bolts, 1 cardboard gasket, 1 rubber gasket, and the top and bottom metal flanges. (Only the top plate is ribbed.)

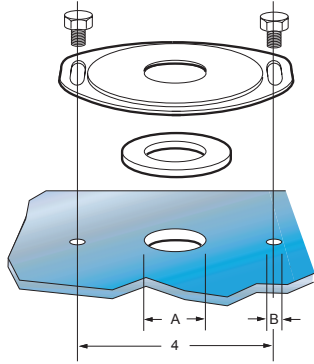

### SPECIFICATIONS—RETURN LINE

PART NO.	TUBE or PIPE SIZE	DIA. A	DIA. B
HA-00-28-8	1/2	1	7/32
HA-00-28-12	3/4	1-1/4	7/32
HA-00-28-16	1	1-1/2	7/32
HA-00-28-20	1-1/4	1-3/4	7/32
HA-00-28-24	1-1/2	2	7/32
HA-00-28-32	2	2-1/2	7/32

**NOTE:** Add "T" to the end of the part number to indicate tube kit or "P" to indicate pipe kit.

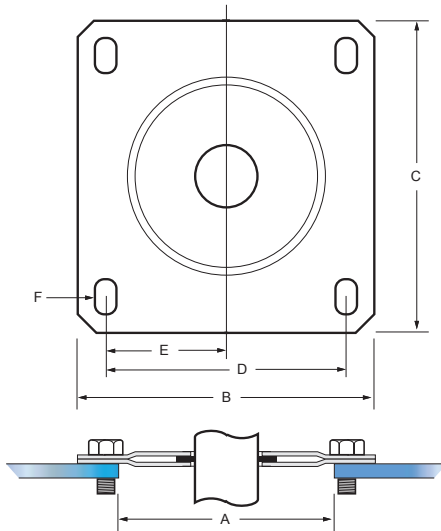

### SPECIFICATIONS—SUCTION LINE

PART NO.	TUBE or PIPE SIZE	A	B	C	D	E	F
HA-00-40-6*	3/8	4.00	5.25	5.50	4.250	2.125	.38 x .62
HA-00-40-8	1/2	4.00	5.25	5.50	4.250	2.125	.38 x .62
HA-00-40-10*	5/8	4.00	5.25	5.50	4.250	2.125	.38 x .62
HA-00-40-12	3/4	4.00	5.25	5.50	4.250	2.125	.38 x .62
HA-00-40-16	1	4.00	5.25	5.50	4.250	2.125	.38 x .62
HA-00-40-20	1-1/4	4.00	5.25	5.50	4.250	2.125	.38 x .62
HA-00-40-24	1-1/2	4.00	5.25	5.50	4.250	2.125	.38 x .62
HA-00-40-32	2	4.00	5.25	5.50	4.250	2.125	.38 x .62

**NOTE:** Add "T" to the end of the part number to indicate tube kit or "P" to indicate pipe kit.

\* Available in tube only. \*\* Available in pipe only.

### WR-28 RETURN LINE FLANGE WELD RISER

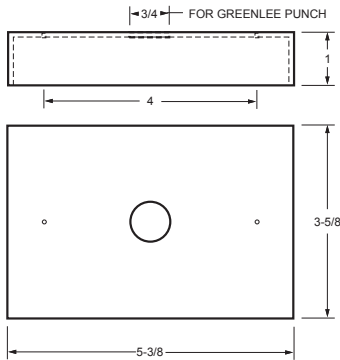

### WR-120 FILLER BREATHER WELD RISER

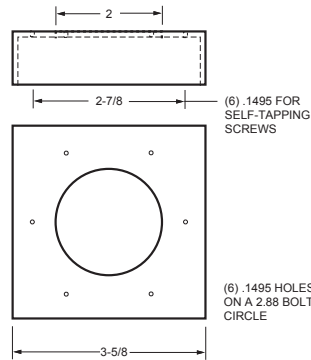

## Weld Risers

### FILLER BREATHER & RETURN LINE WELD RISERS

Hydro-Craft risers are designed to raise fillers and return line openings 1" above the surface of the tank top. This low-cost riser eliminates costly repairs brought on by contamination being swept into the reservoir. The filler riser fits most Hydro-Craft fillers and filler breathers. The return riser fits all Hydro-Craft return line flange kits.

**NOTE:** Also available in stainless steel.



# 4 Bolt Solid Flanges

**NPT OR STRAIGHT THREAD (SAE)  
FOR USE AS CONNECTIONS ON FILTER & PUMP**

Hydro-Craft® steel-constructed solid flanges meet or exceed all SAE standards. They are compatible with any SAE pump or valve. They provide extra convenience for servicing — allow for removing pump or filter without disturbing piping.

"O" ring and bolt kit included.



## SAE

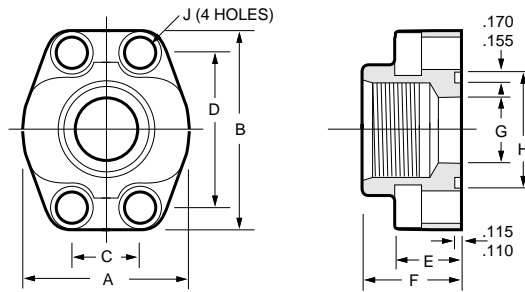

### SPECIFICATIONS—SAE INTERNAL STRAIGHT THREAD - DRILLED HOLES - O-RING

PART NO.	SAE BOSS DASH NO.	TUBE O.D.	PAD SIZE	A	B	C	D	E	F	G	H	J	K	THREAD UN-2B	PSI
F-SAE-12-12	—12	.75	.75	2.06	2.56	.875	1.875	1.25	.84	.75	1.250	.406	.594	1-1/16-12	5000
F-SAE-16-16	—16	1.00	1.00	2.32	2.75	1.031	2.062	1.38	.97	1.00	1.560	.406	.594	1-5/16-12	5000
F-SAE-20-20	—20	1.25	1.25	2.88	3.12	1.188	2.312	1.50	1.03	1.25	1.75	.469	.688	1-5/8-12	4000
F-SAE-24-24	—24	1.50	1.50	3.25	3.69	1.406	2.75	1.62	1.09	1.50	2.115	.531	.781	1-7/8-12	3000

## NPT

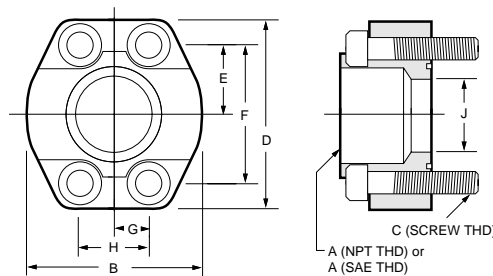

### SPECIFICATIONS—NPT INTERNAL PIPE THREAD - DRILLED HOLES - O-RING

PART NO.	A	B	C	D	E	F	G	H	J	K	L	PSI
HCFT-12-12	3/4	2.06	3/8-16	2.56	.93	1.875	.43	.875	3/4	.53	1.25	5000
HCFT-16-16	1	2.31	3/8-16	2.75	1.03	2.062	.52	1.032	1	.66	1.38	5000
HCFT-20-20	1-1/4	2.88	7/16-14	3.12	1.16	2.312	.59	1.188	1-1/4	.84	1.50	4000
HCFT-24-24	1-1/2	3.25	1/2-13	3.69	1.38	2.75	.70	1.406	1-1/2	.73	1.62	3000
HCFT-32-32	2	3.81	1/2-13	4.00	1.53	3.062	.84	1.688	2	.73	1.62	3000
HCFT-40-40	2-1/2	4.28	1/2-13	4.50	1.75	3.50	1.00	2.00	2.50	.86	2.00	2500
HCFT-48-48	3	5.16	5/8-11	5.31	2.09	4.188	1.22	2.438	3.00	.98	2.25	2500

All dimensions are approximate in inches



The Hydro-Craft® Shock Mount is simple in design, engineered for rugged service and long life. They have an inner cylinder attached to the stud, which is insulated from the outer shell by a wall of mechanically bonded rubber.

They have an ample safety margin:

**Overloaded to destruction they will allow a drop of less than 1/2".**

- Cut down vibration
- Helps subdue shock and noise
- Easy to install
- Inexpensive
- No maintenance required
- Allows precision leveling

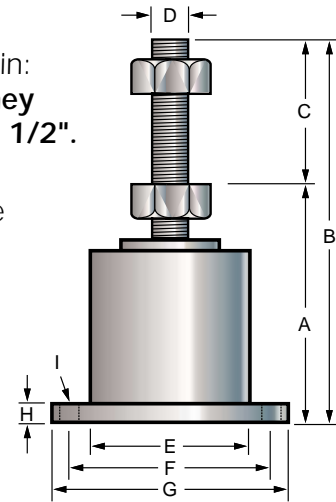

## Shock Mounts

Part Number	HC-SM-31	HC-SM-32	HC-SM-33	HC-SM-35	HC-SM-37	HC-SM-40
Load Capacity* of Each Mount (lbs)	100	200	300	500	750	1000
Shipping Weight Each	10oz.	1lb. 6oz.	1lb. 14oz.	1lb. 10oz.	9 lb.	9 lb.
Maximum (Average) Deflection Under Rated Load (in.)	.0625	.0625	.0625	.0625	.0625	.0625
<b>A</b> Height Floor to Top of Lower Face (Min. Ht. Above Floor) (in.)	1-3/4	2-1/4	4-3/4	3-1/2	4-3/4	4-3/4
<b>B</b> Height Overall, Including Stud (in.)	3	3-3/4	4-3/4	6	8-3/8	8-3/8
<b>C</b> Height of Stud above Lower Face (in.)	1-1/8	1-3/8	2	2-1/2	4	4
<b>D</b> Diameter of Stud (in.)	3/8	1/2	1/2	1/2	1	1
<b>E</b> Diameter of Housing (in.)	1-1/2	1-3/4	2	2-1/8	4-1/2	4-1/2
<b>F</b> Bolt Hole Centers (in.)	2-7/16	2-3/4	3	3-1/2	6-1/2	6-1/2
<b>G</b> Diameter of Base (in.)	3	3-1/2	4	4-7/16	7-3/4	7-3/4
<b>H</b> Flange Height (in.)	11/64	11/64	3/16	3/16	3/8	3/8
<b>I</b> Diameter of Bolt Holes in Base (in.)	5/16	3/8	3/8	3/8	5/8	5/8

**NOTE:** \*Each mount is rated at load capacity (Ex.: If 2,000 lbs. are to be supported, use 10 200 lb shock mounts). Determine the mass to be supported and position mounts in a pattern which will best support load in a balanced condition. Bottom shock mount hex nut must be adjusted up from base to properly suspend mass.

### MOUNTING METHODS

Place plate through shock mount stud, lock both nuts into proper level position. Weld adapters can be inserted into shock mount base and welded into position. Shock mounts can easily be removed by removing nuts from weld pads. Various other mounting configurations can be used.

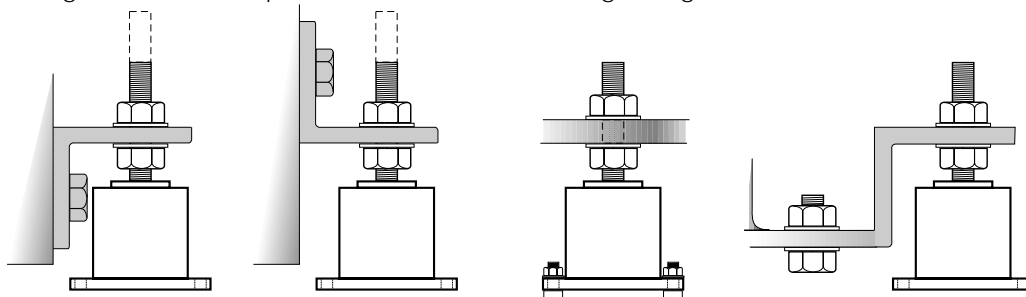

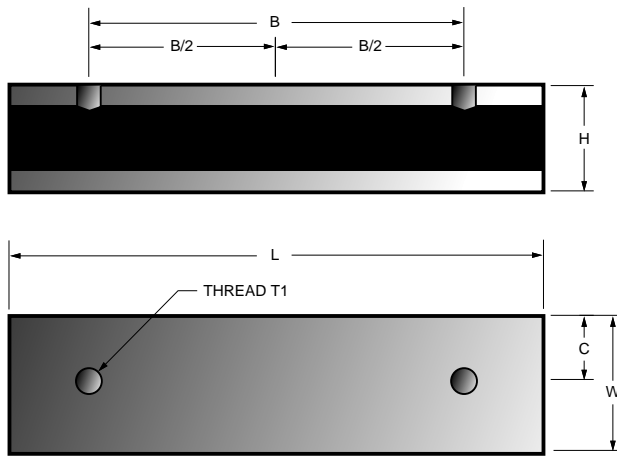

## Motor Dampening Bars

### WELDABLE TYPE

Benefits and Features:

- Reduces both noise levels and vibrations
- Fully machined for NEMA motors
- Vulcanized bonding - not bolted together

### SPECIFICATIONS

PART NO. MOTOR SIZE	DIMENSIONS					
	L	W	H	B	C	T1
HC-56C-W	4-3/4"	2"	1-9/16"	3"	7/8"	5/16-18NC
HC-143TC-W	5-1/2"	2"	1-9/16"	4"	13/16"	5/16-18NC
HC-145TC-W	6-1/2"	2"	1-9/16"	5"	13/16"	5/16-18NC
HC-182TC-W	6"	2"	1-9/16"	4-1/2"	15/16"	3/8-16NC
HC-184TC-W	7-3/4"	2"	1-9/16"	5-1/2"	15/16"	3/8-16NC
HC-213TC-W	7-3/4"	2"	1-9/16"	5-1/2"	15/16"	3/8-16NC
HC-215TC-W	9"	2"	1-9/16"	7"	15/16"	3/8-16NC
HC-254TC-W	10-1/2"	2"	1-3/4"	8-1/4"	15/16"	1/2-13NC
HC-256TC-W	12-1/4"	2"	1-3/4"	10"	15/16"	1/2-13NC
HC-284TC-W	12"	2-3/4"	2-3/8"	9-1/2"	1-1/8"	1/2-13NC
HC-286TC-W	13-1/4"	2-3/4"	2-3/8"	11"	1-1/8"	1/2-13NC
HC-324TC-W	12-1/2"	3-3/16"	2-3/8"	10-1/2"	1-9/16"	5/8-11NC
HC-326TC-W	14"	3-3/16"	2-3/8"	12"	1-9/16"	5/8-11NC
HC-364TC-W	13-1/2"	3-3/16"	2-3/8"	11-1/4"	1-9/16"	5/8-11NC
HC-365TC-W	14-1/2"	3-3/16"	2-3/8"	12-1/4"	1-9/16"	5/8-11NC
HC-404TC-W	15-1/2"	4"	2-3/8"	12-1/4"	2"	3/4-10NC
HC-405TC-W	17"	4"	2-3/8"	13-3/4"	2"	3/4-10NC
HC-444TC-W	21"	4-3/4"	2-3/8"	14-1/2"	2-3/8"	3/4-10NC
HC-445TC-W	21"	4-3/4"	2-3/8"	16-1/2"	2-3/8"	3/4-10NC

\*Note: Normal mount requires 2 pieces.



### SPECIFICATIONS

PART NO.	HEX SIZE	CFM	THREAD SIZE
HCBP-2	1/2	2.5	1/8 NPT
HCBP-4	3/4	3	1/4 NPT
HCBP-6	7/8	3.25	3/8 NPT
HCBP-8	1	4	1/2 NPT
HCBP-12	1-1/4	6	3/4 NPT
HCBP-16	1-1/2	10	1 NPT

## Breather Plugs

Hydro-Craft® breather plugs permit free flow of air and provide filtering and oil separation for gear cases which are vented to atmosphere.

Rugged and durable, they are machined from steel bar stock to precise standards and are finished with a zinc-dichromate plating to resist corrosion.

Hydro-Craft breather plugs contain a porous stainless steel disc micro filter and are especially suited to areas with a high occurrence of fine dust particles, providing filtration down to 35 micron. By breathing from the underside, they are not prone to clogging found in top-breathing plugs.

Hydro-Craft® breather plugs are available in six different sizes.



## Zero-Leak Gold Plugs

Zero-Leak Gold Plugs make affordable zero leak performance a reality. You can replace the standard SAE J514 plugs with the Zero-Leak Gold Plug without engineering or retooling. They're interchangeable and they won't back out. Zero-Leak Gold combines the high integrity of a metal-to-metal seal with an O-ring below the taper as a secondary back-up seal. Plugs are also available in stainless steel.

- Effective in vibration, temperature variation and pressure spike situations
- No chemical sealant required
- Reseal repeatedly without loss of effectiveness
- Regular, magnet and custom styles available
- Interchangeable for standard SAE J514 plugs in SAE J1926 ports

### SPECIFICATIONS

PART NO.	UN 2A THREAD	HEX SOCKET
HCZLP-6	9/16"-18	.25
HCZLP-8	3/4"-16	.313
HCZLP-12	1-1/16"-12	.563
HCZLP-16	1-5/16"-12	.625
HCZLP-20	1-5/8"-12	.75
HCZLP-24	1-7/8"-12	.75
HCZLP-32	2-1/2"-12	.75

**NOTE:** For magnet style, add "M" to part number, as follows: **HCZLMP-6**

Hydro-Craft® magnetic tank traps and plugs are designed to maintain hydraulic systems by picking up ferrous particles that can clog ordinary filters. They are easily installed, and easily cleaned. The Hydro-Craft® AS series Mag Trap features a wipe-clean aluminum shield, eliminating the need for shop air to clean the ferrous particles from the unit.

The magnetic plug is available in 3/4" NPT.

Valuable pump and component protection is provided by these efficient, easily maintained units.



HC-MP-12  
Magnetic Drain Plug

## Hydro-Craft® Magnetic Filtration



Improved magnetic assembly with aluminum shield for easy wipe-clean maintenance and protection of magnets.

WITH ALUMINUM SHIELD

### SPECIFICATIONS

PART NO.	A*
HC-MT-10	10
HC-MT-12	12
HC-MT-16	16
HC-MT-20	20
HC-MT-22	22
<b>HC-MP-12 Drain Plug</b>	

\*Can be cut to length

Add "AS" to end of part number when ordering with aluminum shield  
Example: HC-MT-22AS

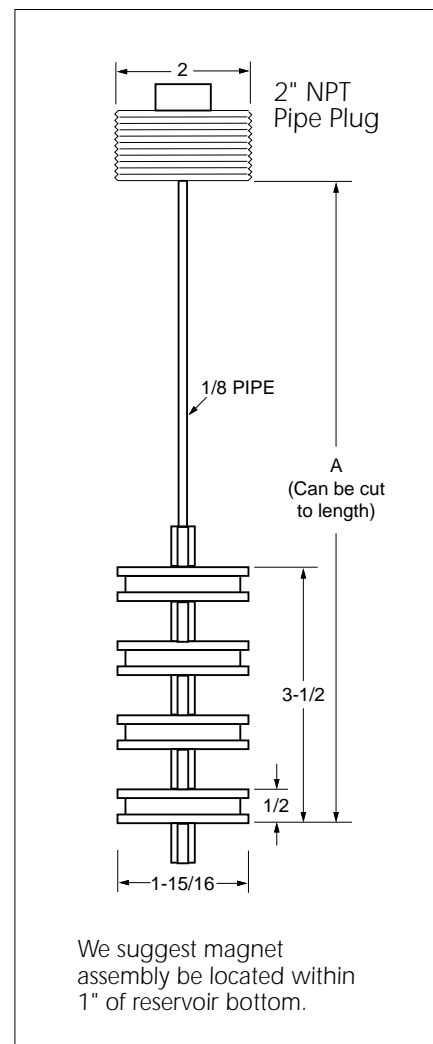

We suggest magnet assembly be located within 1" of reservoir bottom.

All dimensions are approximate in inches

# Plastic Fluid Level Sight Plug - SAE/METRIC/BSP

Has a transparent polyamid lens, for use with solvents, oils with additives, grease, acids, and alkali\*.

- Anodized aluminum reflector and central level sight dot
- NBR synthetic rubber packing ring
- Maximum continuous operating temperature is 230°F (110°C)

\*Avoid contact with alcohol and detergents containing alcohol.

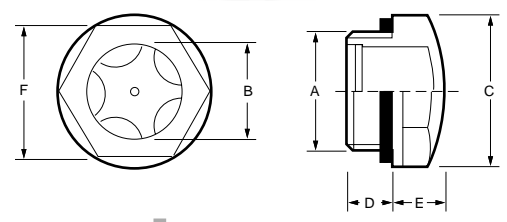

**elesa**® ORIGINAL DESIGN

## SPECIFICATIONS - Order By Part Number

PART NUMBER A Thread	B	C	D Inch (MM)	E	F
<b>SAE</b>					
HC-SP-PR- SAE-3/4x16	0.51 (13)	1.02 (26)	0.59 (15)	0.31 (8)	0.86 (22)
HC-SP-PR- SAE-1-1/16x12	0.75 (19)	1.38 (35)	0.59 (15)	0.39 (10)	1.18 (30)
<b>METRIC</b>					
HC-SP-PR- M-16x1.5	0.43 (11)	0.87 (22)	0.31 (8)	0.28 (7)	0.75 (19)
HC-SP-PR- M-20x1.5	0.55 (14)	1.02 (26)	0.37 (9.5)	0.31 (8)	0.87 (22)
HC-SP-PR- M-25x1.5	0.71 (18)	1.24 (31.5)	0.31 (8)	0.35 (9)	1.06 (27)
HC-SP-PR- M-26x1.5	0.71 (18)	1.24 (31.5)	0.35 (9)	0.35 (9)	1.06 (27)
HC-SP-PR- M-27x1.5	0.79 (29)	1.24 (31.5)	0.51 (13)	0.35 (9)	1.06 (27)
HC-SP-PR- M-30x1.5	0.87 (22)	1.38 (35)	0.35 (9)	0.39 (10)	1.18 (30)
HC-SP-PR- M-35x1.5	0.98 (25)	1.57 (40)	0.43 (11)	0.39 (10)	1.34 (34)
HC-SP-PR- M-40x1.5	1.18 (30)	1.85 (47)	0.47 (12)	0.51 (13)	1.61 (41)
<b>BSP</b>					
HC-SP-PR- BSP-9x1/4	0.35 (9)	0.71 (18)	0.39 (10)	0.24 (6)	0.59 (15)
HC-SP-PR- BSP-12x3/8	0.43 (11)	0.87 (22)	0.31 (8)	0.28 (7)	0.75 (19)
HC-SP-PR- BSP-15x1/2	0.55 (14)	1.02 (26)	0.39 (10)	0.31 (8)	0.87 (22)
HC-SP-PR- BSP-20x3/4	0.79 (20)	1.24 (31.5)	0.39 (10)	0.35 (9)	1.06 (27)
HC-SP-PR- BSP-24x1	0.98 (25)	1.57 (40)	0.43 (11)	0.39 (10)	1.34 (34)
HC-SP-PR- BSP-30x1-1/4	1.18 (30)	1.85 (47)	0.47 (12)	0.51 (13)	1.61 (41)



## Plastic Prism Sight Plug - NPT

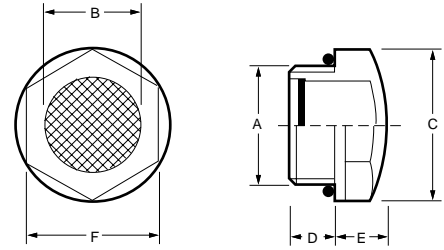

Hydro-Craft® Plastic Sight Plug is a transparent polyamide technopolymer, making it resistant to solvents, oils, greases, and alkaline acids\*.

- Available in 1/2, 3/4, and 1 inch NPT sizes
- Body is made of special black polyamide technopolymer
- Prism lenses
- Flat NBR seal

\*Avoid contact with alcohol and detergents containing alcohol.

### SPECIFICATIONS - Order By Part Number

PART NO.	A THREAD NPT	B	C	D Inch (MM)	E	F
HC-SP-PP-08	1/2	0.55 (14)	1.1 (28)	0.04 (10)	0.31 (8)	0.95 (24)
HC-SP-PP-12	3/4	0.70 (18)	1.38 (35)	0.40 (10)	0.33 (8.5)	1.26 (32)
HC-SP-PP-16	1	0.90 (23)	1.7 (43)	0.43 (11)	0.36 (9)	1.5 (38)

**elesa**® ORIGINAL DESIGN

## Oil Level Sight Plugs

### HYDRO-CRAFT® SIGHT PLUGS ARE DESIGNED FOR QUICK VISUAL INSPECTION OF LIQUID LEVELS

HC-SP Series Plugs use a transparent glass window. Body composed of electroless nickel steel, reflecting surface behind the glass is stainless steel.

- Eliminate the need for dipsticks
- Presence of liquid is clearly shown in window
- Reflecting surface behind the glass provides excellent visibility — even in dark locations
- Compatible with most fluids, including diesel fuel and phosphate esters
- UL rated
- Custom Sight Plugs available, contact Hydro-Craft

#### OIL LEVEL SPECIFICATIONS

PART NO.	NPT	MAX. TEMP.	HEX SIZE	SIGHT AREA
HC-SP-8	1/2	500°F	1	9/16
HC-SP-12	3/4	500°F	1-1/4	3/4
HC-SP-16	1	500°F	1-5/8	1-1/8
HC-SP-24	1-1/2	500°F	2-1/4	1-7/16
HC-SP-32	2	500°F	2-1/2	1-7/8



# Sight Level Gauge

## HSG-66 SERIES

Hydro-Craft® fluid sight level gauges are available in 3- 5- and 10-inch sizes.

- Rugged construction
- Plated steel shell and end blocks
- Standard Lexan tube
- Optional Pyrex glass tube available
- Easy to read, high visibility design
- Viton O-ring tube seals
- Optional dial thermometer available



5- and 10-inch gauges are slotted for side viewing

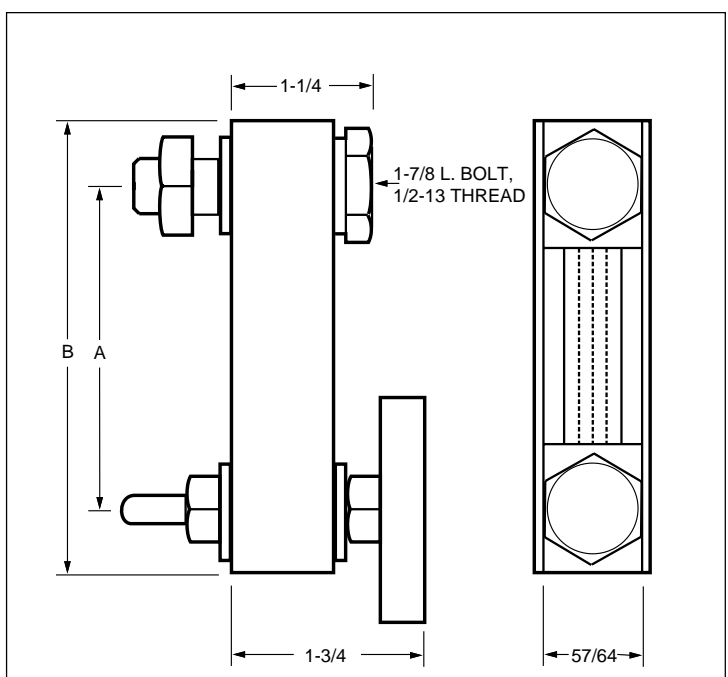

### GAUGE SPECIFICATIONS

PART NO.	PART NO. WITH TEMPERATURE INDICATOR	MOUNTING CENTER (A)	OVERALL LENGTH (B)
HSG-66-3	HSG-66T-3	3	4-1/8
HSG-66-5	HSG-66T-5	5	6-1/8
HSG-66-10	HSG-66T-10	10	11-1/8

Add PL to end of part number for Pyrex, Lexan is standard.

Sight level gauges are not designed for pressure applications.

# Sight/Temperature Gauges

Fluid Level Gauges are made of ultrasonically welded transparent polyamide material, for use with lubricants, mineral, and petroleum based fluids.

- Maximum operating temperature of 212°F (100°C)
- Buna-N o-ring seals
- Zinc plated bolts
- All-around visibility of fluid level



## OPTIONS

- Viton seals
- Fast mount kit available, see below (eliminates mounting from inside the tank)
- For thermometer add T to end of part number
- Special gauges resistant to boiling water and fluids containing alcohol are available, contact Hydro-Craft®

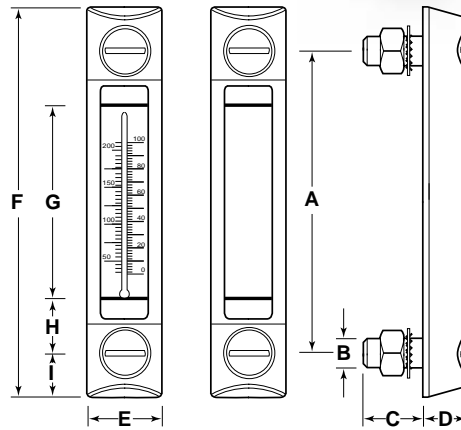

## SPECIFICATIONS

PART NO.	A BOLT CENTER	B	C	D	E	F Inch (MM)	G	H	I	SCALE	
										°C	°F
<b>HSG-77-3</b>	2.99 (76)	(M10)	0.87 (22)	0.63 (16)	1.06 (27)	4.21 (107)	1.57 (40)	0.71 (18)	0.61 (15.5)	20-100	68-210
<b>HSG-77-5</b>	5.00 (127)	(M12)	0.91 (23)	0.71 (18)	1.22 (31)	6.34 (161)	3.15 (80)	0.91 (23)	0.67 (17)	0-100	32-210
<b>HSG-77-10</b>	10.00 (254)	(M12)	0.83 (21)	0.71 (18)	1.38 (35)	11.46 (291)	7.99 (203)	1.02 (26)	0.73 (18.5)	0-100	32-210

Add T to end of part number for thermometer.

## Fast Mounting Kit

For mounting from outside. Buna-N o-ring seal.

## SPECIFICATIONS

PART NO.	A	Without O-Ring		With O-Ring	
		B Min	B Max	B Min	B Max
<b>HSG-77-FM-M10</b>	0.63 (16)	0.06 (1.5)	0.185 (4.7)	0.185 (4.7)	0.25 (6.3)
<b>HSG-77-FM-M12</b>	0.69 (17.5)	0.06 (1.5)	0.185 (4.7)	0.185 (4.7)	0.25 (6.3)

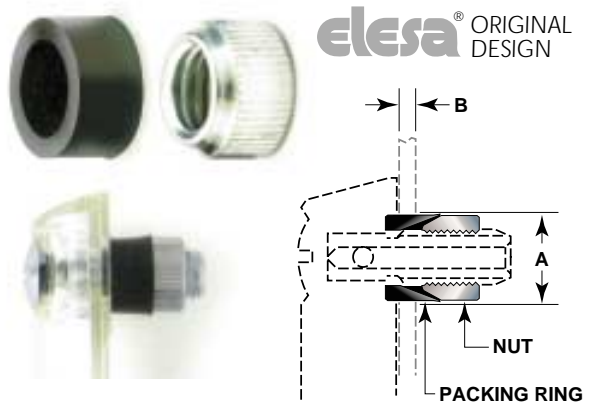



## 5" Electric Sight/Level Gauge

### HSG-77-5-EL SERIES

Electric Sight/Level Gauge generates an electric signal when the oil level drops to a minimum. Also has visual reading.

Transparent polyamide technopolymer is highly resistant to shock, solvents, oils with additives, aliphatic and aromatic hydrocarbons, petro, naphtha, and phosphoric esters\*.

\*Avoid contact with alcohol and detergents containing alcohol.

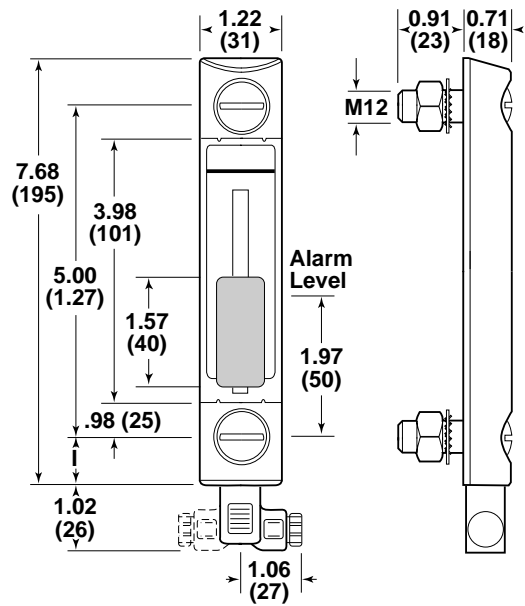

**elesa**® ORIGINAL DESIGN

## Sight Level Gauge\*



Available in black powder coat, add B to end of part number

### PART NUMBER HSG-55

The Hydro-Craft® Standard Sight Level Gauge is available only with temperature indicator. Complete with neoprene gaskets and attaching bolts — ready for immediate installation.

- Can be installed from either outside or inside reservoir unit. Requires only two mounting holes
- Sturdy low profile outer case
- All external metal parts are plated
- Extra large sight area
- Non-breakable 2X magnifier
- Thermometer standard with readings in Centigrade and Fahrenheit
- Will withstand temperatures to 225°F
- Available in stainless steel, add "SS" to end of part number

\*Sight Level gauges are not designed for/cannot be used for pressurized applications.

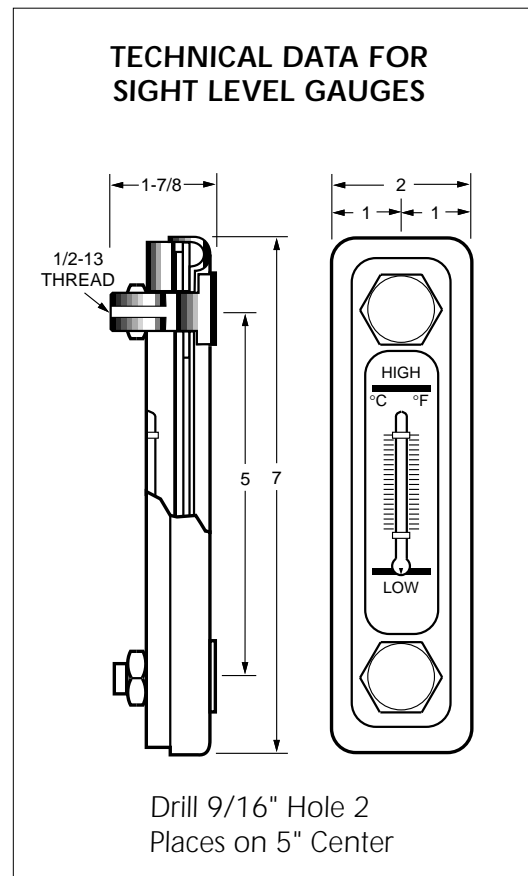

All dimensions are approximate in inches



## Pressure Gauges

2-1/2" AND 4" GLYCERINE TYPE  
Hydro-Craft® gauges are designed for long life under the most severe operating conditions. The glycerine bath dampens the pointer movement, bourdon tube and amplifying device thus ensuring that the effects of system pulsations and mechanical vibrations are reduced to a minimum.

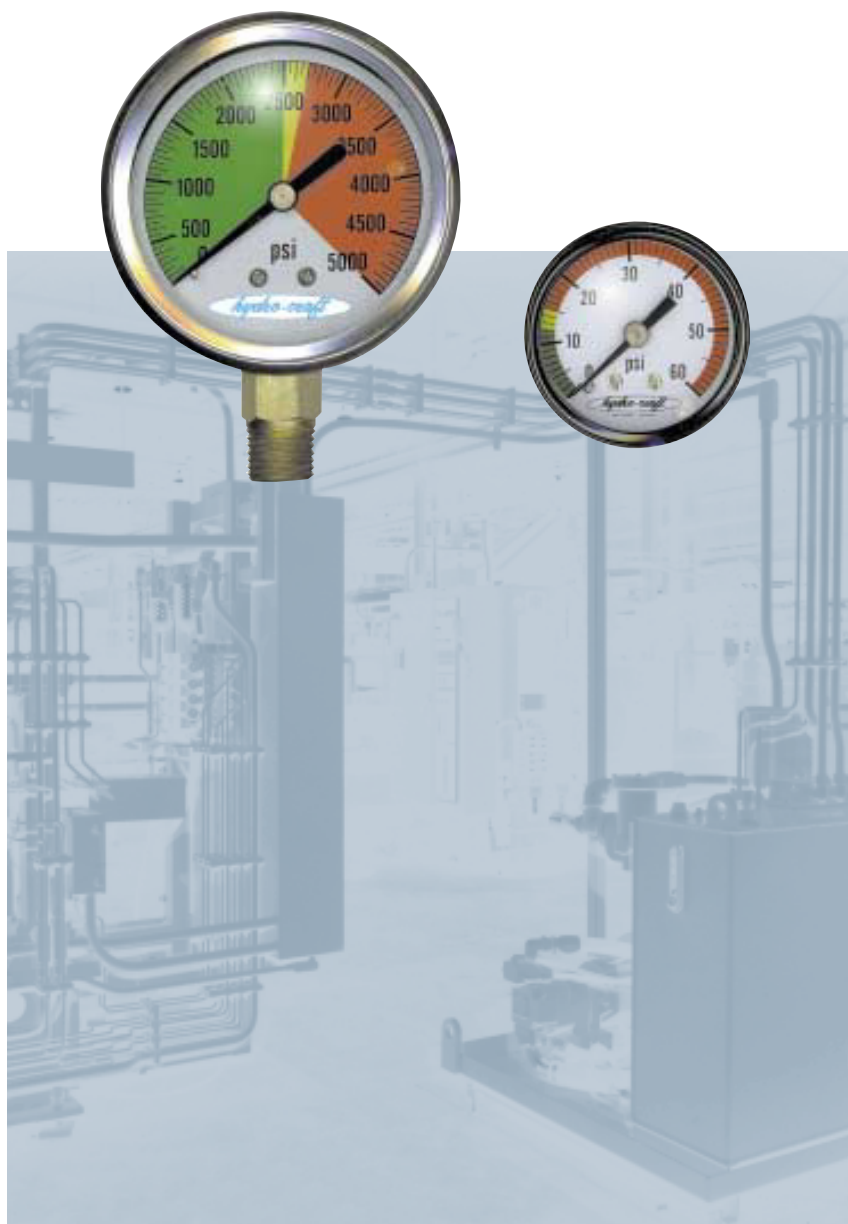

- CASE AND RING: AISI 304 s.s.
- FRONT FLANGE AND BRACKET: AISI 304 s.s.
- DIAL COVER: Plexiglass
- CONNECTION: Brass
- MOVEMENT: Brass
- ACCURACY: grade 1.6% on 2-1/2", grade 1% on 4"
- RANGES AND GRADUATIONS: in both psi (black) and bar (red)
- MAXIMUM DIAL READING SELECTION: 75% on 2-1/2", 90% of scale range for fluctuating pressure and 100% of scale for steady pressure on 4"
- PRESSURE ELEMENT: on 2-1/2" models "C" shaped bourdon bronze tube for pressures to 600 psi and in multi-spiral for the upper pressure. On 4" model "C" shaped bourdon bronze tube for ranges up to 600 psi. For upper ranges multi-spiral in AISI 316L s.s.
- WARRANTY: Material and design faults within 12 months from date of purchase when used under normal operating conditions
- All glycerine gauges include a dual relief valve/blowout disc for operational safety

# Pressure Gauges

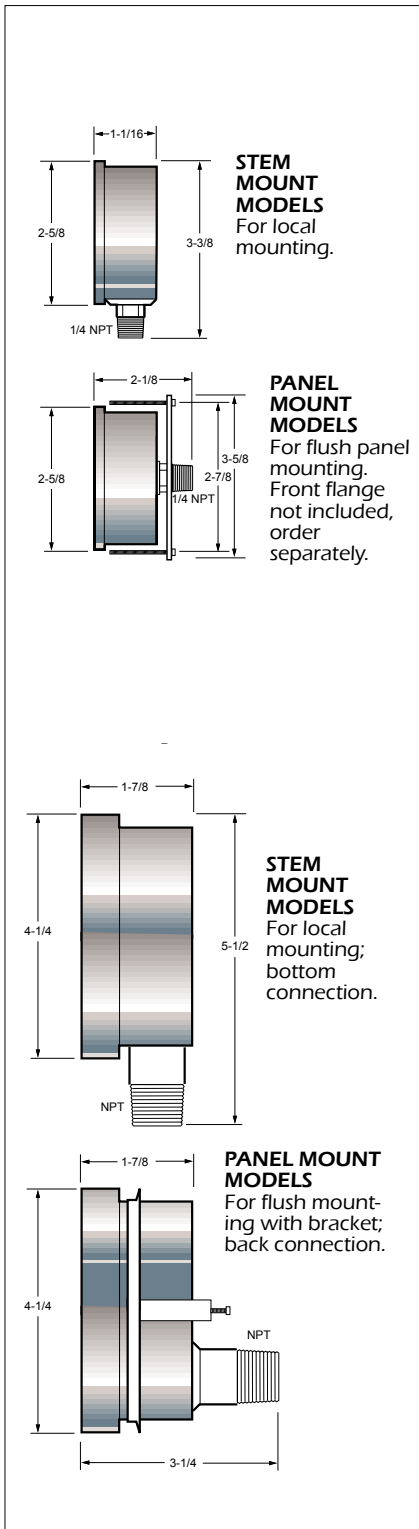

## SPECIFICATIONS—2-1/2 INCH GLYCERINE GAUGES

2-1/2 Inch (63mm) Series

PART NO.		RANGE	
STEM MOUNT	PANEL MOUNT	PSI	BAR
HC1V-002S	HC1V-002P	-30 Hg + 30	-1 + 2
HC1V-000S	HC1V-000P	-30 Hg-0	-1
HC1P-004S	HC1P-004P	0-60	0-4
HC1P-007S	HC1P-007P	0-100	0-7
HC1P-010S	HC1P-010P	0-160	0-10
HC1P-020S	HC1P-020P	0-300	0-20
HC1P-040S	HC1P-040P	0-600	0-40
obsolete HC1P-055S	obsolete HC1P-055P	obsolete 0-800	obsolete 0-55
HC1P-070S	HC1P-070P	0-1000	0-70
HC1P-100S	HC1P-100P	0-1500	0-100
HC1P-140S	HC1P-140P	0-2000	0-140
HC1P-210S	HC1P-210P	0-3000	0-210
HC1P-350S	HC1P-350P	0-5000	0-350
HC1IP-420S	HC1P-420P	0-6000	0-420
HC1P-700S	HC1P-700P	0-10000	0-700
	HC1P-F	<b>FRONT FLANGE ONLY</b>	

## SPECIFICATIONS—4 INCH GLYCERINE GAUGES

4 Inch (100mm) Series

PART NO.		RANGE		NPT (Inches)
STEM MOUNT	PANEL MOUNT	PSI	BAR	
HC2V-000S	HC2V-000P	-30 Hg + -0	-1	1/4
HC2P-004S	HC2P-004P	0-60	0-4	1/4
HC2P-007S	HC2P-007P	0-100	0-7	1/4
HC2P-010S	HC2P-010P	0-160	0-10	1/4
HC2P-020S	HC2P-020P	0-300	0-20	1/4
HC2P-040S	HC2P-040P	0-600	0-40	1/4
HC2P-070S	HC2P-070P	0-1000	0-70	1/2
HC2P-100S	HC2P-100P	0-1500	0-100	1/2
HC2P-140S	HC2P-140P	0-2000	0-140	1/2
HC2P-210S	HC2P-210P	0-3000	0-210	1/2
HC2P-350S	HC2P-350P	0-5000	0-350	1/2
HC2P-700S	HC2P-700P	0-10000	0-700	1/2
HC2P-800S	HC2P-800P	0-15000	0-1050	1/2
	HC2P-F	<b>FRONT FLANGE ONLY</b>		

All dimensions are approximate in inches



# Gauge Isolator Valves

**SINGLE STATION**—Hydro-Craft® push-to-read gauge isolator valve protects pressure gauges from damaging pressure surges, hydraulic shock and mechanical vibrations.

Fluid is completely isolated from the gauge until the knob is pressed. By pressing the knob, fluid is connected directly to the gauge port giving instant and accurate readings on the gauge. As the knob is released, the spring loaded valve closes automatically connecting the gauge port to drain and completely blocking the pressure port.

In operation, an orifice in the gauge port acts as a partial snubber, protecting the gauge from the initial surge of fluid as the knob is pressed.

The valve is easily and attractively panel mounted with the included screws.

The unit has a steel body with hardened steel spool. By using this type of gauge isolator, savings are ensured on the life of your pressure gauge.

**NOTE:** Vent port connection must drain into tank above oil level to insure proper operation of valve. These valves are designed for non-pressurized reservoirs.

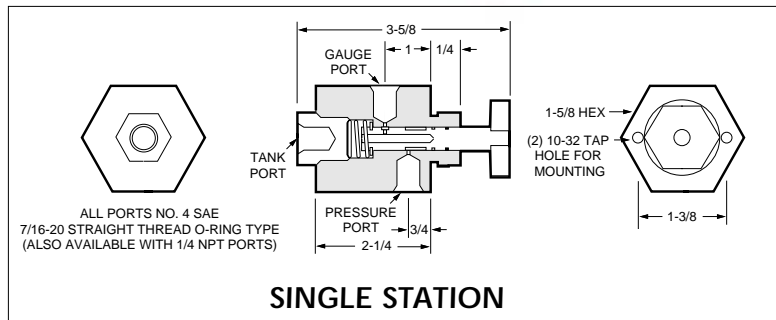

## SPECIFICATIONS

PART NO.	DESCRIPTION	MAXIMUM WORKING PRESSURE
HC-G1-02-ST	Single Station Straight Thread	3000 PSI
HC-G1-02	Single Station 1/4 NPT Thread	3000 PSI

**MULTIPLE STATION**—Reliable 6-station isolator protects and prolongs life of expensive pressure gauges. Though basically designed for panel mounting, the unique design of this isolator makes it suitable for a variety of applications and mounting methods. To use, simply turn knob to desired station and press to read gauge. Valve automatically vents itself.

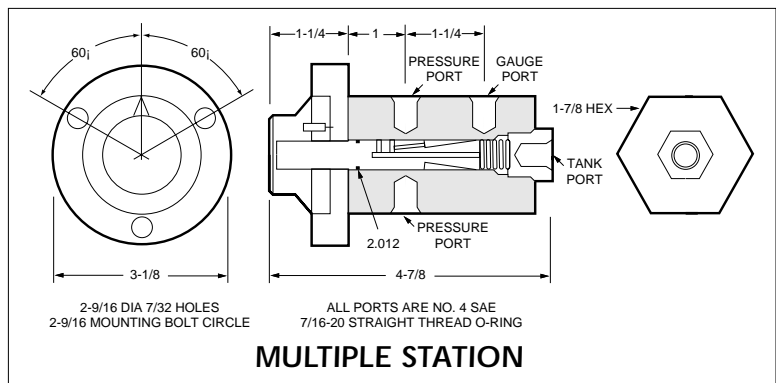

## SPECIFICATIONS

PART NO.	DESCRIPTION	MAXIMUM WORKING PRESSURE	WEIGHT
HC-G1-02-6A	Six Station	3000 PSI	2.75 LBS.

# Gauge Panels

## SINGLE & MULTIPLE

Hydro-Craft® gauge panels provide the reliability of Hydro-Craft® gauges and isolator valves in a complete, ready-to-install panel.

- Gauges are 2-1/2" or 4" diameter, glycerine filled
- 6"x12" gauge panel size is standard
- Panel material is zinc-plated steel
- Maximum working pressure: 3000 P.S.I.

### SINGLE STATION

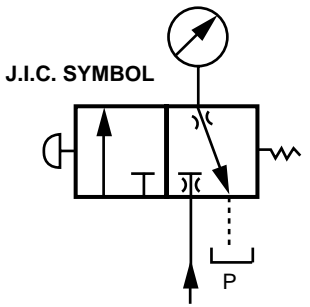

### MULTIPLE STATION

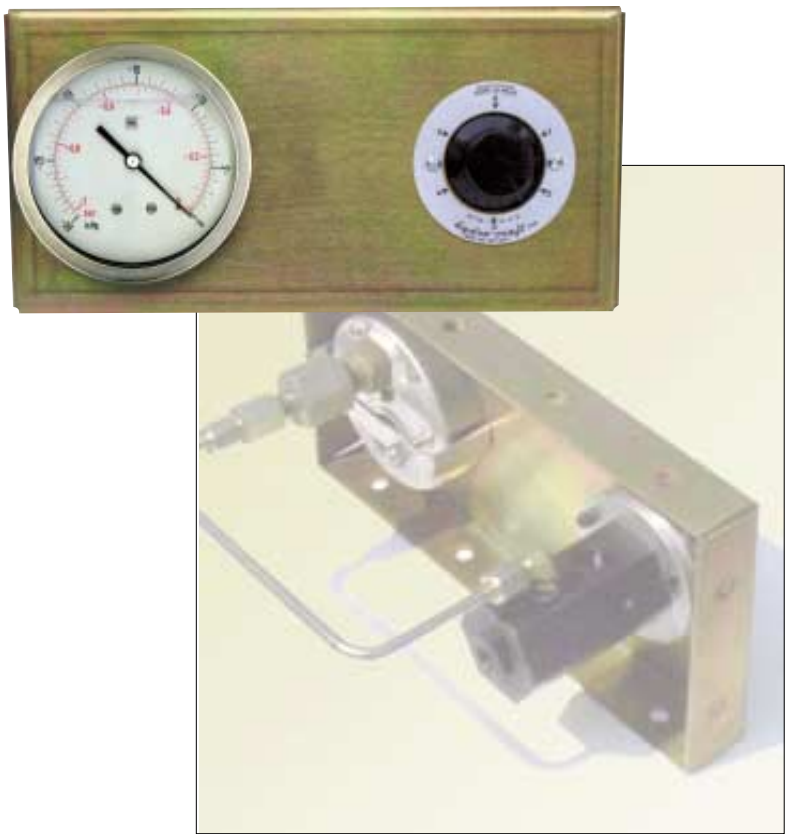
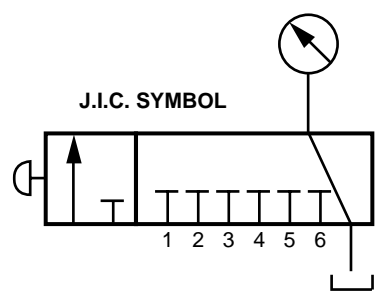

## SPECIFICATIONS

PART NO.	DESCRIPTION
HCGP1-02-1-*	1 Station 2-1/2" Gauge
HCGP2-02-1-*	1 Station 4" Gauge
HCGP1-02-6-*	6 Station 2-1/2" Gauge
HCGP2-02-6-*	6 Station 4" Gauge

\*Specify PSI on gauge

All dimensions are approximate in inches



Filler Breather with 4" strainer

Filler Breather with optional stainless steel filler screen and dipstick



## Filler Breather Assembly Kit

PART NO. HC-120

- Nylon strainer with guard...stronger than conventional materials. Will not corrode. Compatible with most fluids.
- Flange on strainer acts as gasket—no unnecessary parts to lose
- 3" or 8" strainer available, 4" is standard
- Displaces 192 gallons per minute (25 CFM)
- Available in 10 or 40 micron
- Nylon strainer with openings equivalent to 30 mesh
- Plated cap with safety chain
- All Parts included in one carton, ready to install
- Locking provision available to accept standard 3/8" padlock
- Pressurized breather available, see Optional Adders on page 31 for ordering information

### OPTIONAL ADDERS

Add To Part	Description
AS	Anti-Slosh Feature
B	Black Powder Coated Cap
D	6" Dip Stick
L	Stainless Steel Locking Tab
M	10 Micron Element
PB-3	3 P.S.I. Pressurized Breather
PB-5	5 P.S.I. Pressurized Breather
PB-10	10 P.S.I. Pressurized Breather
S-3	3" Stainless Steel Strainer
S-4	4" Nylon Strainer
SS-8	8" Stainless Steel Strainer

### FEATURES

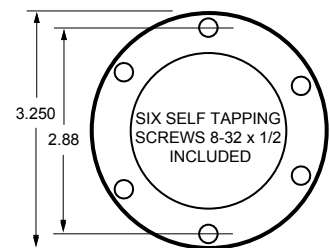

See page 14 for Weld Risers

All dimensions are approximate in inches



Patent Pending

## Anti-Slosh Filler-Breathers

**ELIMINATES SPLASHING IN SPECIFIC HYDRAULIC APPLICATIONS**

Hydro-Craft's new Anti-Slosh Filler-Breather cap meets high quality standards and the special needs of mobile hydraulic applications. It offers the same features and benefits of our standard, non-pressurized filler-breathers and easily replaces existing caps. It fits threaded or bayonet style assemblies. They allow a large amount of air flow with little or no slosh.

Features and options in addition to the Anti-Slosh design include nylon strainer with guard, locking cap, metal filler strainer in two depths, dipstick, safety chain, black powder coating on cap\*, side mounting assembly kit, and custom colors (in quantity). OEMs can order these in their proprietary colors with their name and/or logo stamped into the cap (i.e., John Deere green or Caterpillar yellow).

© Hydro-Craft, Inc. John Deere and Caterpillar remain the copyright of the respective companies.

\* Powder coating has withstood 400 hours in a salt-spray cabinet with no adverse effect.

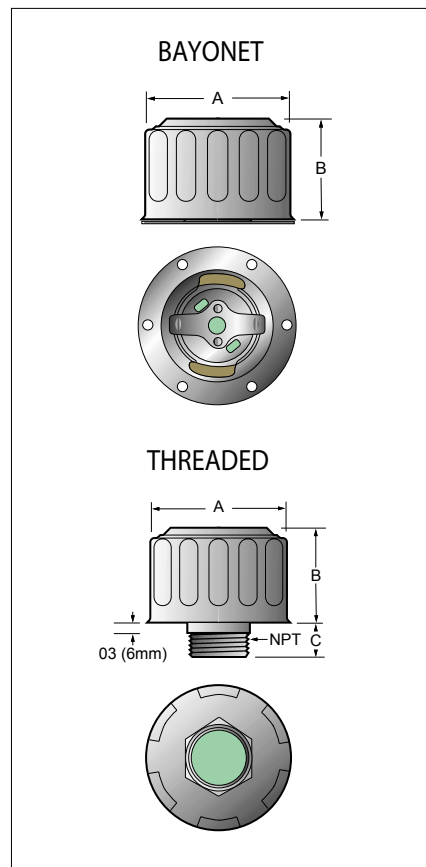

OPTIONAL ADDERS	
ADD TO PART	DESCRIPTION
AS	Anti-Slosh Feature
B	Black Powder Coated Cap
D	6" Dip Stick
L (discontinued)	Stainless Steel Locking Tab
M	10 Micron Element
S-3	3" Stainless Steel Strainer
S-4	4" Nylon Strainer
SS-8	8" Stainless Steel Strainer

### How To Order

Example: HC-120-AS-B-D-SS-8

This example would provide you a filler-breather with the following options: anti-slosh, black powder coated cap, 6" dip stick, and 8" stainless steel strainer.

### SPECIFICATIONS—NON-PRESSURIZED

PART NO.	FLOW (CFM)	SIZE (NPT)	A	B	C	MICRON
THREADED HC-120-T-12-P-AS	25	3/4	3	2-3/8	3/4	40
BAYONET HC-120-AS	25	-	3	2-1/4	-	40

## HOW TO ORDER

Part No.	Description
HC-120	40 Micron Filler Breather w/4" nylon strainer
HCS-M-120	40 Micron Metal Side Mount Filler Breather w/ 3" metal strainer

### OPTIONAL ADDERS

Add To Part	Description
AS	Anti-Slosh Feature
B	Black Powder Coated Cap
D	6" Dip Stick
L (discontinued)	Stainless Steel Locking Tab
M	10 Micron Element
PB-3	3 P.S.I. Pressurized Breather
PB-5	5 P.S.I. Pressurized Breather
PB-10	10 P.S.I. Pressurized Breather
S-3	3" Stainless Steel Strainer
S-4	4" Nylon Strainer
SS-8	8" Stainless Steel Strainer

Example: HC-120-D-L-PB-3-SS-8

3 PSI Pressurized Breather with a 6" Dip Stick, stainless steel locking tab and 8" stainless steel strainer.



## Metal Side Mount Filler Breather Assembly Kit

PART NO. HCS-M-120

- Displaces 192 gallons per minute. (25 CFM)
- Available in 10 or 40 micron
- 3" strainer filters out particles as small as 300 micron
- CAD-plated steel housing
- Nickel chrome plated cap with safety chain
- All Parts (gaskets, self-tapping screws), included in one package—ready to install

### FEATURES

- Specially designed slots provide for an extremely large amount of air flow through cap
- Safety chain retains cap so it will not be misplaced

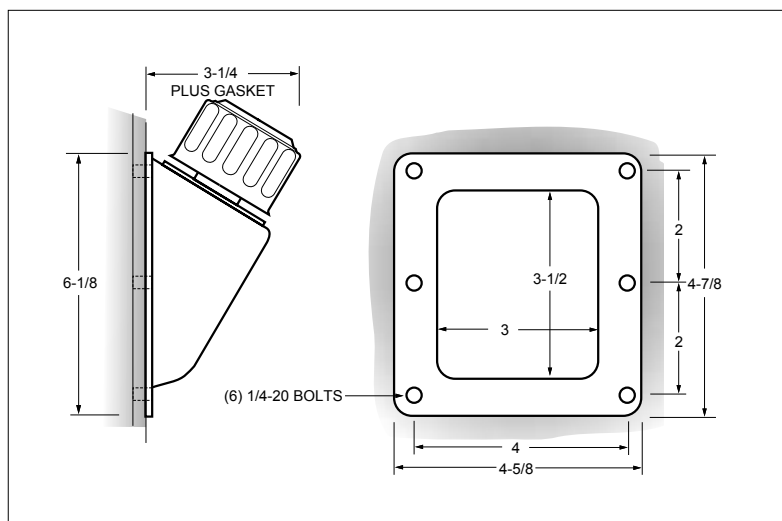

Dimensional data for Metal Side Mount

All dimensions are approximate in inches





HC-120-T-32-P

## Air Breathers

Breather filters are a must for hydraulic systems requiring clean air passing into the reservoir, ensuring long life of system components.

When used as a crankcase ventilator, it helps to prolong the life of the engine oil and the oil filter.

Pressurized breather available, see Optional Adders on page 31 for ordering information.



HC-120-P-T-12P-3

### SPECIFICATIONS—THREADED TYPE, PRESSURIZED

PART NO.	RATING MICRON	DISPLACEMENT GPM	AIR FLOW cfm	NPT
HC-120-P-T-12P-3	40	192	25	3/4
HC-120-P-T-12P-5	40	192	25	3/4
HC-120-P-T-12P-10	40	192	25	3/4

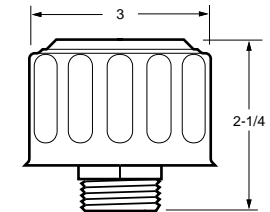

### SPECIFICATIONS—THREADED TYPE, NON PRESSURIZED

PART NO.	FLOW CFM	SIZE (NPT)	A	B	C	MICRON
HC-120-T-4P	10	1/4	1-13/16	2-1/8	3/4	40
HC-120-T-12-P	25	3/4	3	1-3/4	3/4	40
HC-120-T-24-P	75	1-1/2	5-5/32	4-1/4	1-1/4	40
HC-120-T-32-P	120	2	5-13/16	6-1/2	2-9/16	40
HC-120-T-40-P	190	2-1/2	7	8-1/4	2-3/4	40
HC-120-T-48-P	280	3	7	8-1/4	2-3/4	40
HC-120-T-64-P	500	4	7	8-1/4	3-7/8	40

Contact Hydro-Craft® for replacement elements

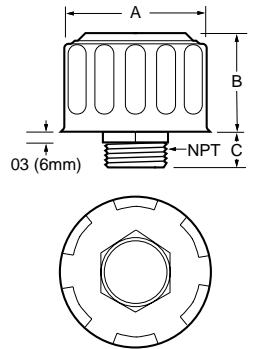

HC-120-T-4P  
HC-120-T-12P

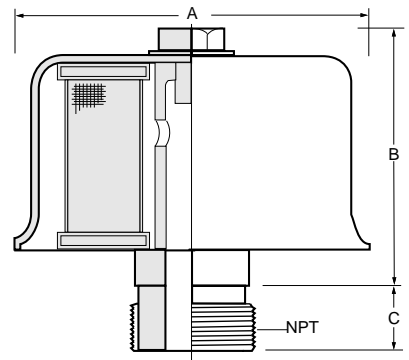

HC-120-T-24P

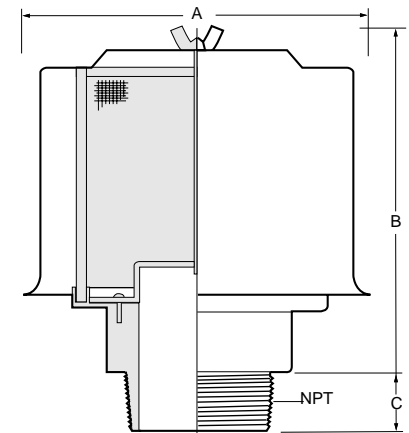

HC-120-T-40P





## Valve Breather Caps

Valve Breather Caps are high-impact technopolymer construction making them resistant to solvents, oils, greases, and other chemical agents.

- RAL orange cover with graphic symbol "valve", and black threaded connector
- Flat NBR synthetic rubber packing ring
- Aluminum valve covered with adhesive-proof material pad sealing o-ring
- Stainless steel ring
- Valve setting is 100mb: valve opens when pressure exceeds 0.100 bar, 1.4 psi

### SPECIFICATIONS

PART NO.	DESCRIPTION	A	B INCHES (MM)	C	D
HC-PB-P-6	3/8 NPT	1.18 (30)	1.22 (31)	0.39 (10)	0.39 (10)
HC-PB-P-8	1/2 NPT	1.18 (30)	1.22 (31)	0.39 (10)	0.39 (10)

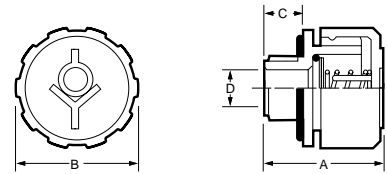

**elesa**® ORIGINAL DESIGN

## Filler Breathers — Screw-In Style — Anti-Slosh — NPT

Filler Breathers are high-impact construction. Resistant to solvents, oils, grease, and other chemicals.

- 1.65 inch cap diameters
- Temperature range -22°F to +240°F (-30°C to +115°C)
- Displacements to 250 gpm without baffle, 144 gpm with baffle
- Anti-Slosh feature prevents oil loss

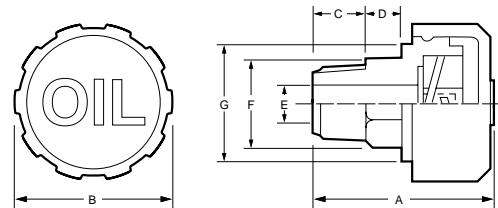

### SPECIFICATIONS

PART NO.	Description	A	B	C	D INCHES (MM)	E	F	G	
STANDARD	ANTI-SLOSH								
HC-PB-4	HC-PB-AS-4	1/4 NPT	1.53 (39)	1.65 (42)	0.39 (10)	0.27 (7)	0.27 (7)	5/8	1.18 (30)
HC-PB-6	HC-PB-AS-6	3/8 NPT	1.73 (44)	1.65 (42)	0.59 (15)	0.27 (7)	0.31 (8)	3/4	1.18 (30)
HC-PB-8	HC-PB-AS-8	1/2 NPT	1.85 (47)	1.65 (42)	0.67 (17)	0.27 (7)	0.47 (12)	1	1.18 (30)
HC-PB-12	HC-PB-AS-12	3/4 NPT	1.85 (47)	1.65 (42)	0.70 (18)	0.27 (7)	0.70 (18)	1-1/8	1.18 (30)
HC-PB-12-57		3/4 NPT	1.97 (50)	2.24 (57)	0.70 (18)	0.27 (7)	0.63 (16)	1-1/8	1.53 (39)
HC-PB-12-70		3/4 NPT	1.97 (50)	2.76 (70)	0.70 (18)	0.23 (6)	0.63 (16)		1.53 (39)

Optional custom dipstick available, contact Hydro-Craft



HC-RS-30D  
Dial  
Indicator



## Return Line Filters

The Hydro-Craft® range of spin-on filters are designed for return line applications and have a nominal retention of 10 micron as standard. 25 micron canisters are available.

Hydro-Craft offers three basic models which are interchangeable with most suppliers of this filter type. The filters are rated at 200 PSI (13 bar) working pressure with bypass, and have flow rates of 15 to 50 GPM at 10 micron. **WARNING:** 80 PSI  $\Delta P$  maximum pressure without bypass valve in filter head.

Hydro-Craft® spin-on filters are designed for use with mineral-based oils as used in mobile, industrial, marine and agricultural applications.

### DESIGN FEATURES

- Full flow 10 micron—standard
- Optional 25 micron
- 200 PSI working pressure with bypass
- Interchangeable elements
- Visual indicator available in standard or custom design
- Disposable spin-on canister
- With 15 PSI bypass (1 bar)

### SPECIFICATIONS

PART NO.	PORT SIZE (NPT)	FLOW RATE (GPM)	MICRON RATING	DIAL INDICATOR
<b>30 SERIES</b>				
HC-RS-30-12X	3/4"	15	10 Micron Std. 25 Micron Opt.	No
HC-RS-30-12D	3/4"	15	10 Micron Std. 25 Micron Opt.	Yes
HC-RS-30-16X	1"	20	10 Micron Std. 25 Micron Opt.	No
HC-RS-30-16D	1"	20	10 Micron Std. 25 Micron Opt.	Yes
<b>50 SERIES</b>				
HC-RS-50-20X	1-1/4"	55	10 Micron Std. 25 Micron Opt.	No
HC-RS-50-20D	1-1/4"	55	10 Micron Std. 25 Micron Opt.	Yes
<b>BAYONET FILTER ADAPTER</b>				
HC-120-BFA				
HC-120-FA				

Our Bayonet Flange Adapters, HC-120-BFA and HC-120-FA, will replace the filler breather cap, allowing use of a spin-on filter. The flange adapter will accommodate all series RSE filters. Select the appropriate size and micron rating for your application.

### REPLACEMENT ELEMENTS

PART NO.	MICRON RATING
<b>30 SERIES</b>	
RSE-30-10	10 Micron
RSE-30-25	25 Micron
<b>50 SERIES</b>	
RSE-50-10	10 Micron
RSE-50-25	25 Micron

Replacement dial gauge indicator  
HCRS-30-D fits 30 and 50 series filters

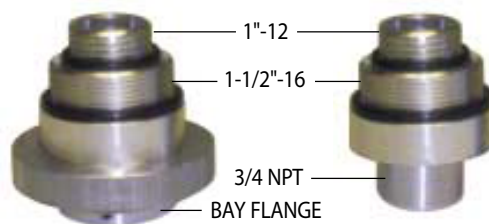

HC-120-BFA                      HC-120-FA  
Bayonet Filter Adapters

All dimensions are approximate in inches

# Return Line Filters Series HCRS 30 and 50

## TECHNICAL DATA

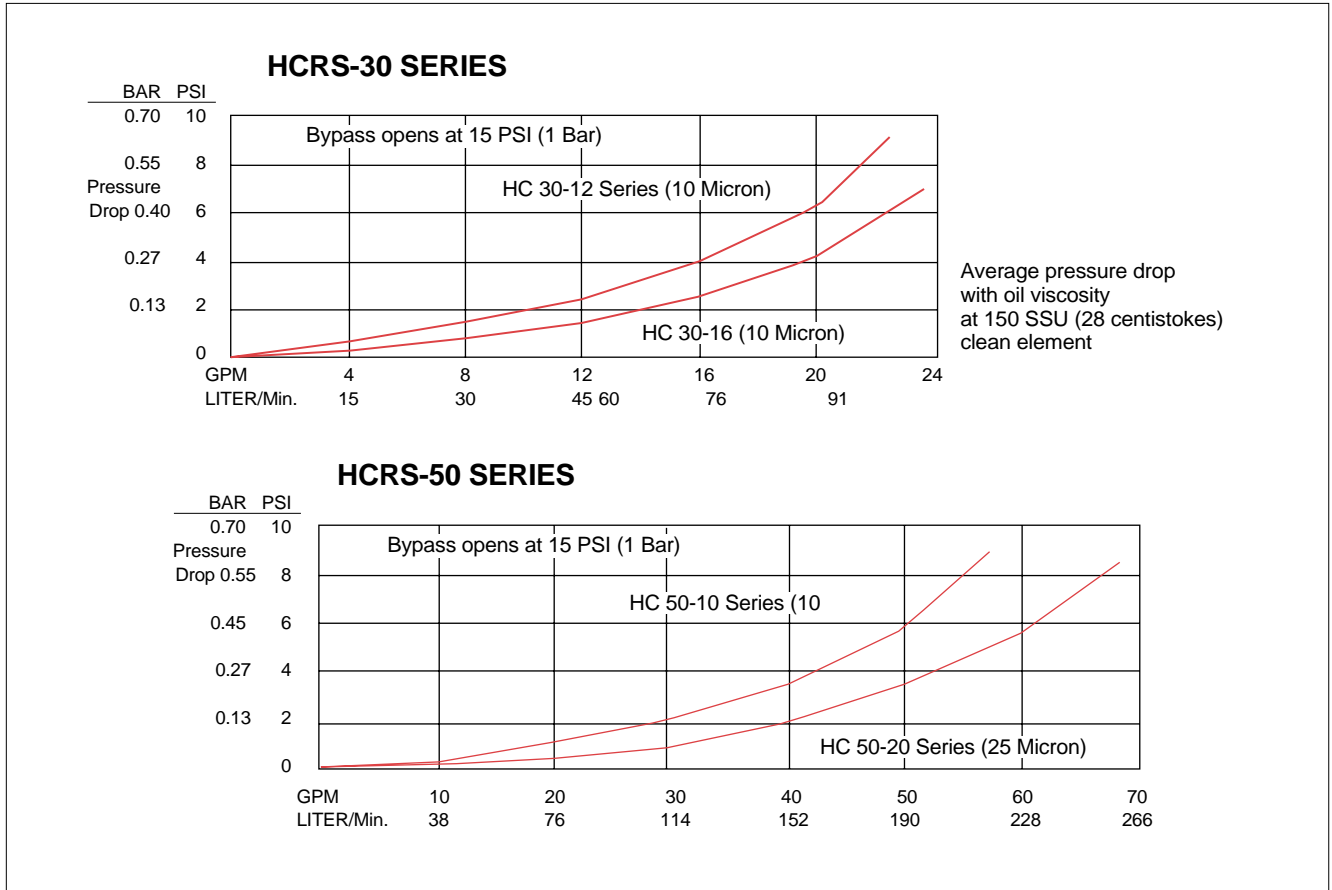
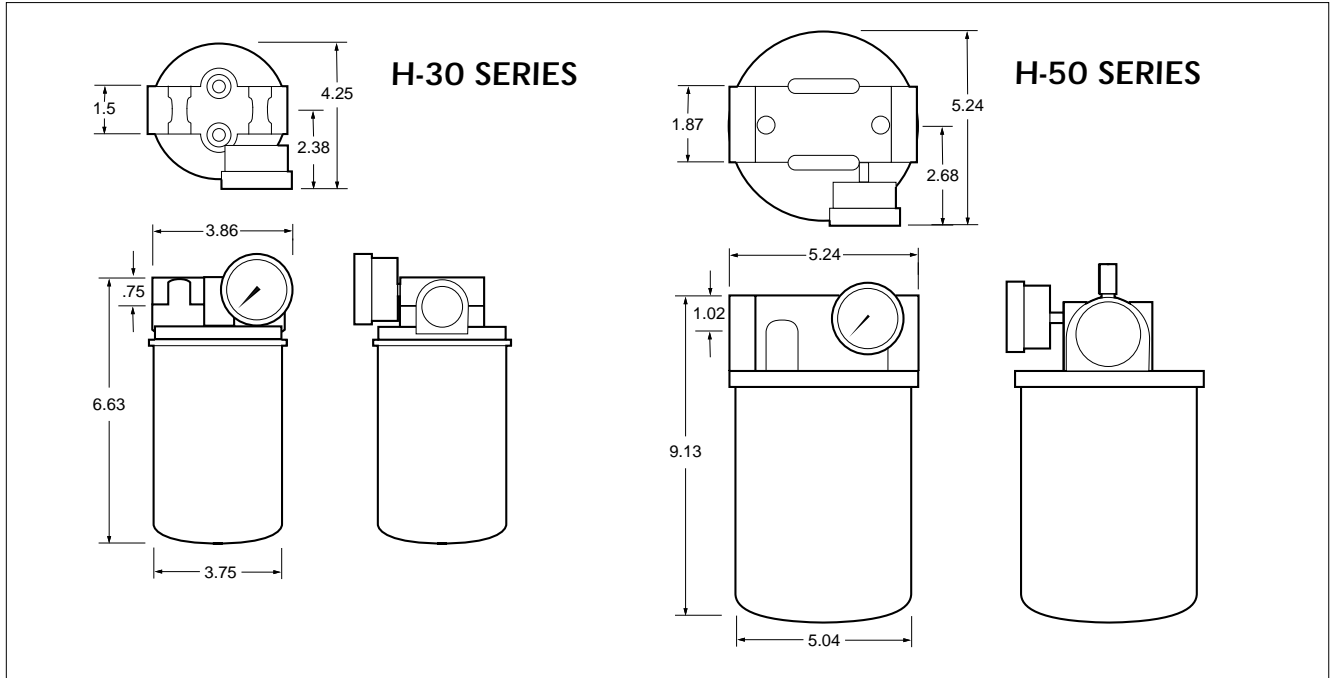



TRFA 08  
TRFA 12  
TRFA 16  
2-HOLE  
MOUNT

TRFA 20  
4-HOLE  
MOUNT

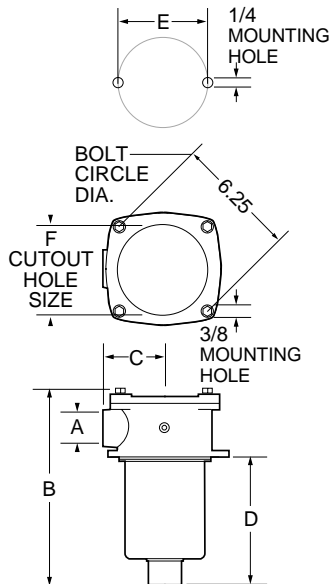

## TRFA Return Line Filter

Hydro-Craft® TRFA return line filters are available in 4 port sizes, 1/2, 3/4, and 1" (2-hole mount), and 1-1/4" (4-hole mount).

### FEATURES:

- Materials:  
Head & cover: Aluminum alloy  
Bowl: Polyamide  
Bypass valve: Polyamide  
Seals: Nitrile
- Working temperature from -15° to 230°F
- Maximum working pressure 45 psi
- Up to 65 GPM with 10 micron cellulose element

### SPECIFICATIONS

PART NO.	A	B	C	D	E	F
TRFA 08	1/2	5.32	1.97	3.15	3.54	2.64
TRFA 12	3/4	6.97	2.64	4.02	4.53	3.5
TRFA 16	1	8.86	2.64	5.91	4.53	3.5
TRFA 20	1-1/4	13.35	3.74	9.76	6.25	5.0

SEE PAGE 37 FOR HOW TO ORDER

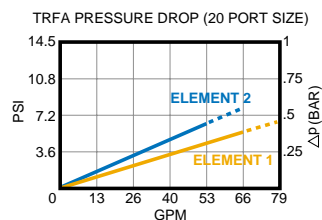
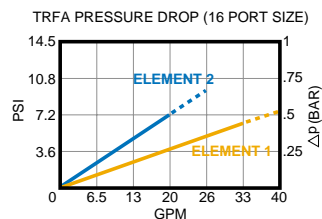
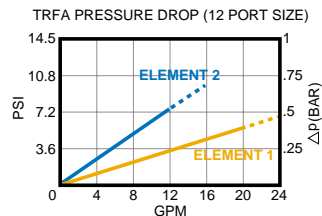
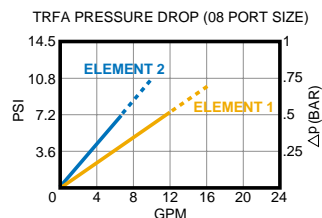

## TRFH Return Line Filter

Hydro-Craft® TRFH is a double 1-1/4" port filter. Built to the highest standards, it assures years of trouble-free service.

### FEATURES:

- Materials:  
Head & cover: Aluminum alloy  
Bowl: Polyamide  
Bypass valve: Polyamide  
Seals: Nitrile
- Working temperature from -15° to 230°F
- Maximum working pressure 45 psi
- Up to 65 GPM with 10 micron cellulose element

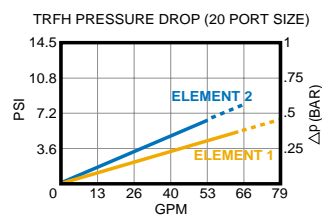
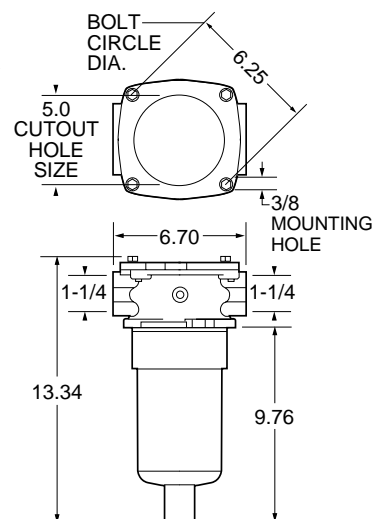

SEE PAGE 37 FOR HOW TO ORDER

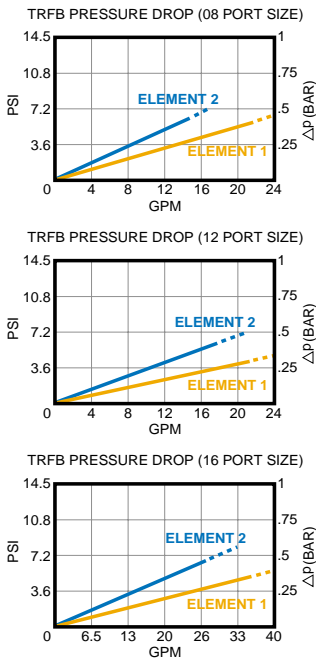

# TRFB Return Line Filter

Hydro-Craft® TRFB return line filters are made in 3 port sizes, 1/2, 3/4, and 1". Comes with a built-in breather. All filter end caps have a handle for easy element removal and cleaning.

### FEATURES:

- Materials:
  - Head & cover: Aluminum alloy
  - Bowl: Polyamide
  - Bypass valve: Polyamide
  - Seals: Nitrile
- Working temperature from -15° to 230°F
- Maximum working pressure 100 psi
- Up to 40 GPM with 10 micron cellulose element

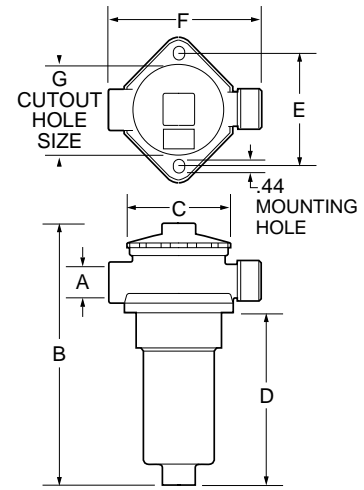

### SPECIFICATIONS

PART NO.	A	B	C	D	E	F	G
TRFB 08	1/2	9.57	2.95	7.01	3.22	4.73	2.36
TRFB 12	3/4	7.87	4.09	4.33	4.33	6.03	3.45
TRFB 16	1	10.43	4.09	6.89	4.52	6.03	3.45

## HOW TO ORDER RETURN LINE FILTERS

Build an ordering code, as in example below:

EXAMPLE: TRFB 12 N 1 EC 1

#### SERIES

- TRFA
- TRFB
- TRFH

#### PORT SIZE

- 1/2" (2 BOLT) TRFA, TRFB only = **08**
- 3/4" (2 BOLT) TRFA, TRFB only = **12**
- 1" (2 BOLT) TRFA, TRFB only = **16**
- 1-1/4" (4 BOLT) TRFA, TRFH only = **20**

#### PORT STYLE or Element Only

- SAE = **S**
- NPT = **N**
- ELEMENT ONLY = **XE**

#### DIPSTICK TRFB only

- 1** = SPECIAL 15" DIPSTICK

#### CLOGGING INDICATOR

- X** = NONE, PLUGGED
- VS** = VISUAL BOTTOM MOUNT
- VP** = VISUAL BACK MOUNT
- EC** = ELECTRIC SWITCH

#### ELEMENT

- 1** = 10 MICRON NOMINAL CELLULOSE
- 2** = 12 MICRON ABSOLUTE SYNTHETIC

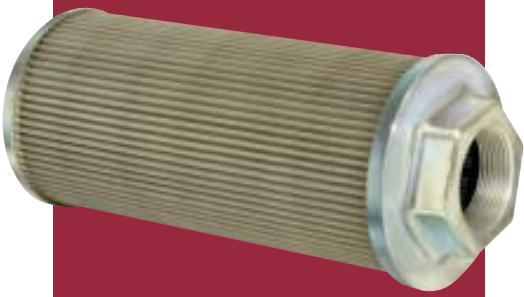

## Suction Line Filter

**IN-TANK SUBMERGED TYPE** Hydro-Craft® offers a complete range of suction-line filters, for use with hydraulic fluids, lubricants, coolants, cutting oil, etc.

### FEATURES:

- Meets or exceeds all J.I.C. standards
- 140 micron filtering
- 100 mesh stainless steel screen
- Aluminum nut and end caps
- Epoxied ends, hex connection
- Extremely low pressure drops
- Minimum sizes – maximum flow rates
- Gallon rating and micron size stamped on each filter

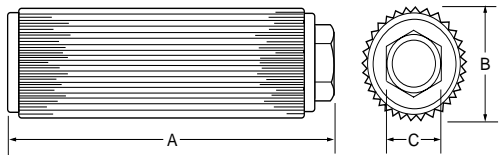

Pressure drop through a clean element will not exceed 0.2 PSI (0.4-in. Hg) at rated flow of 150 SSU viscosity fluid and 100 mesh.

### SPECIFICATIONS

Hydro-Craft® recommends hand-tightening only to facilitate servicing...wrench tightening is not necessary.

PART NUMBER		VALVE OPTION	GPM RATING	THREAD (NPTF)	FILTERING AREA (SQ. IN.)	METAL			
ALL METAL	NYLON CONNECTION					A	B	B	C
HA-FS-5	HP-FS-5	"ADD" RV-3 3-PSI BY PASS	5	3/4"	62	3-1/2"	3-9/32"	3-3/16"	1-5/16"
HA-FS-10	HP-FS-10		10	1"	125	5-3/4"	3-9/32"	3-3/16"	1-5/8"
HA-FS-20	HP-FS-20		20	1-1/4"	162	7-3/8"	3-9/32"	3-3/16"	1-15/16"
HA-FS-30	HP-FS-30		30	1-1/2"	310	9-1/8"	4-9/32"	4-3/16"	2-1/8"
HA-FS-50	HP-FS-50		50	2"	340	9-3/4"	4-9/32"	4-3/16"	2-3/4"
HA-FS-75	HP-FS-75		75	2-1/2"	400	12-1/2"	5-7/16"	5-3/16"	3-1/2"
HA-FS-100	HP-FS-100		100	3"	500	12-1/2"	5-7/16"	5-3/16"	4"

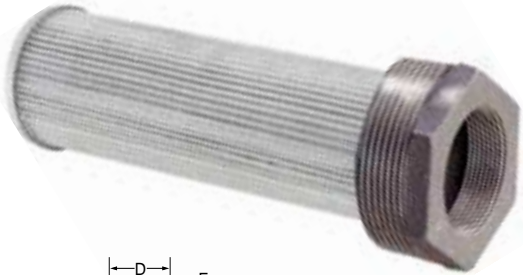

## Tank-Mounted Strainers

Hydro-Craft® strainers mount through the wall of the tank. They can be removed through the mounting hole, so access to tank interior is not necessary.

### FEATURES:

- Available in NPT or STRAIGHT THREAD
- Custom strainers available, contact Hydro-Craft®
- Optional bypass valve available

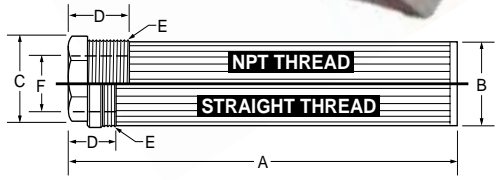

### SPECIFICATIONS

NPT PART NUMBER	VALVE OPTION	GPM RATING	FILTERING AREA (SQ. IN.)	A	B	C	D	THREAD E	THREAD F
HTS-FS-5		5	35	5.38"	1.18"	1.43"	1.10"	1"	1/2"
HTS-FS-10	"ADD"	10	64	7.50"	1.14"	1.81"	1.20"	1-1/4"	3/4"
HTS-FS-15	RV-5	15	86	8.25"	1.65"	2.00"	1.30"	1-1/2"	1"
HTS-FS-25	5-PSI	25	125	10.00"	2.12"	2.55"	1.30"	2"	1-1/4"
HTS-FS-50	BYPASS	50	260	10.25"	3.03"	3.30"	1.70"	3"	2"
HTS-FS-100		100	315	11.30"	3.78"	5.00"	1.80"	4"	3"
STRAIGHT THREAD									
HTSS-FS-16	"ADD"	16	90	9.00"	2.24"	2.13"	.75"	2-1/2"-12	1-5/16"-12
HTSS-FS-20	RV-5	20	90	9.00"	2.24"	2.13"	.75"	2-1/2"-12	1-5/8"-12
HTSS-FS-24	5-PSI	24	230	8.80"	3.22"	2.50"	.90"	3-3/8"-12	1-7/8"-12
HTSS-FS-32	BYPASS	32	230	9.30"	3.22"	3.00"	.98"	3-3/8"-12	2-1/2"-12





## FLEXIBLE INSERT GUIDE

MODEL SIZE	MAX BORE	Wr <sup>2</sup> lb-ft <sup>2</sup>	INSERT No.	RATED lb-in	TORSIONAL RIGIDITY lb-in/Deg	HORSE POWER RATING AT (RPM)		
						100	1200	1800
PM 90	1-1/8	.946	P097N7	224	38.3	.36	4.3	6.5
			P090U9	336	69.9	.54	6.5	9.8
			P090H5	672	158.7	1.08	13.	19.5
100	1-1/8	.0046	M170N7	340.7	42	.55	6.5	9.8
			M170U9	511.0	53	.82	9.8	14.7
			M170H5	1022.1	182	1.65	19.8	29.7
200	1-3/8	.0068	M270N7	398.3	55	.64	7.6	11.5
			M270U9	597.4	68	.96	11.5	17.2
			M270H5	1194.9	234	1.92	23.0	34.5
300	1-5/8	.022	M370N7	701.4	81	1.12	13.5	20.2
			M370U9	1052.1	148	1.68	20.2	30.3
			M370H5	2104.2	336	3.36	40.4	60.6
400	1-7/8	.031	M470N7	1056.3	138	1.69	20.3	30.4
			M470U9	1584.5	310	2.5	30.4	45.6
			M470H5	3168.9	488	5.1	60.8	91.3
500	2-3/8	.071	M570N7	2194.8	314	3.5	42.1	63.2
			M570U9	3292.2	695	5.3	63.2	94.8
			M570H5	6584.4	1571	10.5	126.4	189.6
600	2-5/8	.16	M670N7	4946.7	676	7.9	94.9	142.5
			M670U9	7420.1	1510	11.9	142.5	213.7
			M670H5	14840.1	2960	23.7	284.9	427.4
700	2-7/8	.34	M770N7	11639.8	1805	18.6	223.5	335.2
			M770U9	17459.7	2104	27.9	335.2	502.8
			M770H5	29099.5		46.5	558.75	838.0
800	3-7/8	.95	M870N7	21889.4	3680	35.0	420.3	630.4
			M870U9	32834.1		52.5	630.4	945.6
			M870H5	47062.2		75.2	903.0	1354.5
900	4-3/4	4.20	M970N7	47842.3	8428	76.5	918.6	1377.9
			M970U9	71763.5		114.8	1377.9	2066.8

## Flexible Drive Couplings

Hydro-Craft® offers the original lightweight, heavy duty flexible drive coupling. Solid magnesium alloy permanent mold castings are heat treated and offer the highest strength-to-weight ratio available. Light weight magnesium construction makes the coupling 76% lighter than iron and 36% lighter than aluminum units of similar design. The benefits include reduced loads on bearings, shafts and pumps for longer component life, easier handling and installation and rust proof and corrosion resistant design.

**BLACK MATERIAL - NEOPRENE (Code N)** - Standard insert with coupling. Good general purpose material offering good resiliency and load capabilities. Temp Range -30°F to +250°F. Optional 80A durometer (painted Gold) and 90A durometer (painted Silver) are available for slight increase in load capacity and less resiliency.

**PAINTED BLUE - NITRILE (Buna N)(Code B)** - Excellent material with petroleum products. Excellent compression set and abrasion resistance characteristics. Temp range -60°F to +250°F.

**YELLOW MATERIAL - URETHANE (Code U)** - Excellent mechanical and physical properties. Offers good medium duty and resiliency. Urethane tends to soften in higher temperatures and swells in humid conditions. Temp range -30°F to +150°F.

**RED MATERIAL - VITON™ (Fluorocarbon)(Code V)** - Excellent fluid compatibility and high temperature characteristics. Good compression set and resiliency. Temp range -20°F to +350°F.

**BLUE-GREEN MATERIAL - HYTREL™ (Code H)** - Superior physical and mechanical properties and excellent fluid compatibility and high temperature characteristics. Hardness (50D) approaches that of plastic and offers little resiliency. Excellent performance under heavy duty conditions. Temp range -65°F to +300°F.



## Keyway Flexible Drive Couplings

Hydro-Craft® couplings features:

**PRECISION MACHINED** - The coupling's wide, outside diameter is machined to  $\pm .001$  inch and the bore is machined concentric to this diameter within  $.002$  inch T.I.R.

**SIMPLE DESIGN** - Radial Lug Design is logical and efficient. Coupling's drive lugs are in a true radial orientation and applied forces are evenly distributed in the compressive direction only, eliminating the heat generating radial component.

**FLEXIBILITY** - Couplings offer four-way flexibility (parallel, angular, axial and torsional) and require no lubrication.

**EASY ALIGNMENT** - Wide, precision machined outside surfaces permit a simple, but accurate alignment procedure.

### HOW TO ORDER:

Keyway Coupling part may be specified using the following format:  
Use chart on page 41.

- Start with the letter 'M', follow with 3 digit model code (100, 200, etc).
- Then specify 5 bore key code.

### EXAMPLE:

Model 500 hub with  
1-3/8 bore and 5/16 keyway:

**M50011210**

### MODEL PM 90 DIMENSIONS

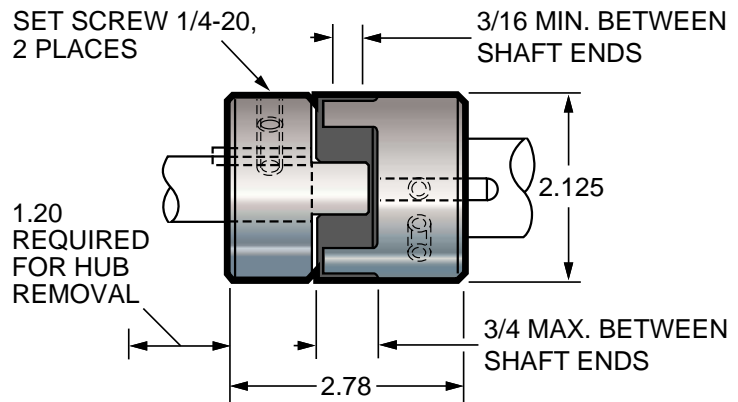

### MODELS 100-900 DIMENSIONS

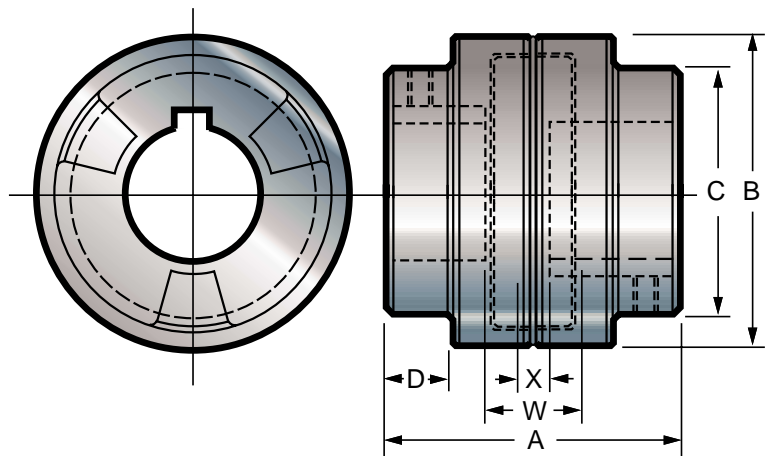

### DIMENSIONS

COUPLING MODEL	A	B	C	D	W(Max)	X(Min)
100	2.54	2.60	2.00	.56	3/4	1/16
200	3.10	2.90	2.25	.68	7/8	1/16
300	3.58	3.45	2.90	.78	7/8	1/16
400	4.24	3.98	3.05	1.00	1-1/8	1/16
500	4.67	4.80	4.00	1.04	1-1/4	1/16
600	5.98	5.98	4.50	1.60	1-3/8	1/16
700	6.99	6.90	5.19	2.08	1-7/8	1/16
800	7.99	8.60	7.00	2.25	2.00	1/16
900	10.15	11.40	8.30	2.75	1-1/2	1/16

All dimensions are approximate in inches

### STANDARD BORE AND KEYWAY COMBINATIONS

PART NO.	BORE/KEY CODE	PART NO. BORE x KEY	MODEL CODE											
			PM90	100	200	300	400	500	600	700	800	900		
M_ _ _	01203	3/8 x 3/32		•	•									
M_ _ _	01403	7/16 x 3/32	•	•	•									
M_ _ _	01404	7/16 x 1/8	•	•	•									
M_ _ _	01604	1/2 x 1/8	•	•	•	•								
M_ _ _	01804	9/16 x 1/8	•	•	•	•								
M_ _ _	02005	5/8 x 5/32	•	•	•	•								
M_ _ _	02006	5/8 x 3/16	•	•	•	•	•							
M_ _ _	02206	11/16 x 3/16	•	•	•	•	•							
M_ _ _	02404	3/4 x 1/8	•	•	•	•								
M_ _ _	02406	3/4 x 3/16	•	•	•	•	•	•	•					
M_ _ _	02806	7/8 x 3/16	•	•	•	•	•	•	•					
M_ _ _	02808	7/8 x 1/4	•	•	•	•	•	•	•					
M_ _ _	03008	15/16 x 1/4				•	•							
M_ _ _	10006	1 x 3/16	•	•	•	•	•	•	•					
M_ _ _	10008	1 x 1/4	•	•	•	•	•	•	•					
M_ _ _	10408	1-1/8 x 1/4	•	•	•	•	•	•	•					
M_ _ _	10608	1-3/16 x 1/4			•		•							
M_ _ _	10808	1-1/4 x 1/4			•	•	•	•	•					
M_ _ _	10810	1-1/4 x 5/16			•	•	•	•	•	•				
M_ _ _	11210	1-3/8 x 5/16			•	•	•	•	•	•				
M_ _ _	11212	1-3/8 x 3/8				•								
M_ _ _	11412	1-7/16 x 3/8				•	•	•	•					
M_ _ _	11610	1-1/2 x 5/16					•	•	•					
M_ _ _	11612	1-1/2 x 3/8				•	•	•	•	•				
M_ _ _	12012	1-5/8 x 3/8				•	•	•	•	•				
M_ _ _	12412	1-3/4 x 3/8				•	•	•	•	•				
M_ _ _	12414	1-3/4 x 7/16					•	•	•	•				
M_ _ _	12816	1-7/8 x 1/2					•	•	•	•	•		•	
M_ _ _	13016	1-15/16 x 1/2						•						
M_ _ _	20016	2 x 1/2						•	•	•	•	•	•	•
M_ _ _	20416	2-1/8 x 1/2						•	•	•	•	•	•	•
M_ _ _	20816	2-1/4 x 1/2						•	•	•	•	•	•	•
M_ _ _	21220	2-3/8 x 5/8						•	•	•	•	•	•	•
M_ _ _	21620	2-1/2 x 5/8						•	•	•	•	•	•	•
M_ _ _	22020	2-5/8 x 5/8						•	•	•	•	•	•	•
M_ _ _	22420	2-3/4 x 5/8						•	•	•	•	•	•	•
M_ _ _	22824	2-7/8 x 3/4								•	•	•	•	•
M_ _ _	30024	3 x 3/4										•	•	•
M_ _ _	30824	3-1/4 x 3/4										•	•	•
M_ _ _	31228	3-3/8 x 7/8										•	•	•
M_ _ _	31628	3-1/2 x 7/8										•	•	•
M_ _ _	32028	3-5/8 x 7/8										•	•	•
M_ _ _	32428	3-3/4 x 7/8										•	•	•
M_ _ _	32832	3-7/8 x 1										•	•	•
M_ _ _	40032	4 x 1												•
M_ _ _	40432	4-1/8 x 1												•
M_ _ _	40832	4-1/4 x 1												•
M_ _ _	41232	4-3/8 x 1												•
M_ _ _	41632	4-1/2 x 1												•
M_ _ _	41640	4-1/2 x 1-1/4												•
M_ _ _	42040	4-5/8 x 1-1/4												•
M_ _ _	42440	4-3/4 x 1-1/4												•



## Splined Flexible Drive Couplings

### HOW TO ORDER:

Spline Coupling part may be specified using the following format:

- Start with the letter 'M', follow with 3 digit model code (100, 200, etc).
- Next use single letter Spline Type Identifier Code ('A' for regular spline, or 'B' for steel bushing).
- Then specify 4 digit spline code.
- If a clamp type coupling is specified - use the letter code 'C' after the spline code.

### EXAMPLES:

Model 300 hub with 13 tooth 16/32 spline bore: **M300-A1316**

Same as above w/steel bushing: **M300-B1316**

Same as above w/steel bushing and clamp: **M300-B1316C**

## DIMENSIONS-CLAMP TYPE COUPLING

PART NO.	BOLT LOCATION		U BOLT SIZE	TORQUE SPECS
	Z	Y		
100	.31	.68	1/4-20	130-140 in. lbs
200	.43	.75	1/4-20	130-140 in. lbs
300	.47	.95	5/16-18	210-220 in. lbs
400	.69	1.06	5/16-18	210-220 in. lbs
500	.72	1.25	3/8-16	300-310 in. lbs
600	1.13	1.50	7/16-14	35-36 ft. lbs
700	1.13	1.75	7/16-14	35-36 ft. lbs
800	1.44	2.56	1/2-13	49-50 ft. lbs
900*	.75 & 2.19	3.00	3/4-10	100-110 ft. lbs

\*Model 900 utilizes two bolt clamp design

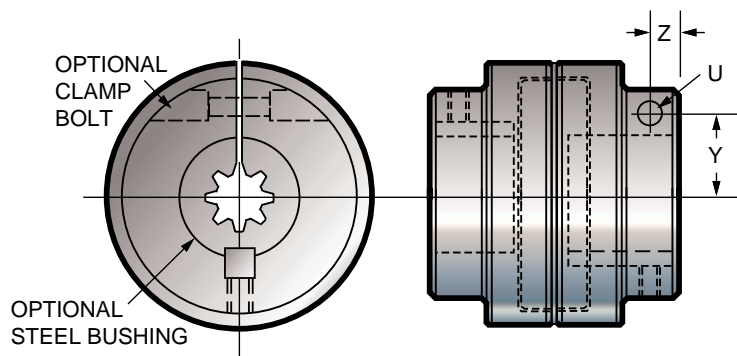

### SPLINE TYPE IDENTIFIER CODE:

- A = Spline
- B = Steel Bushing Spline
- C = Clamp Type

## SPECIFICATIONS

NUMBER OF TEETH	SPLINE SIZE PITCH	SPLINE CODE	PRESSURE ANGLE DEGREE	SAE DESIGN	MAJOR DIAMETER (inches)	STANDARD COUPLING MODEL SIZES	STEEL BUSHED STANDARD MODEL SIZES	SIZE GROUP
9	16/32	0916	30°	A	.625	100-400	200-400	A
13	8/16	1308	30°	D,E	1.750	400-700	600-800	B
13	16/32	1316	30°	B	.875	100-500	300-500	A
14	12/24	1412	30°	C	1.250	200-700	500-700	B
15	16/32	1516	30°	BB	1.000	300-500	400-600	A
15	8/16	1508	30°	F	2.000	500-700	800	C
17	12/24	1712	30°	CC	1.500	500-700	500-800	B
21	16/32	2116	30°		1.375	300-600	500-600	B
23	16/32	2316	30°		1.500	500-600	500-700	B
27	16/32	2716	30°		1.750	500-700	600-800	B
40	16/32	4016	30°		2.5625	NONE	NONE	C

All dimensions are approximate in inches





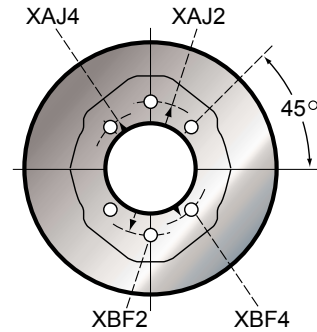
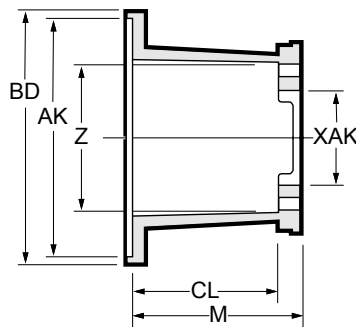
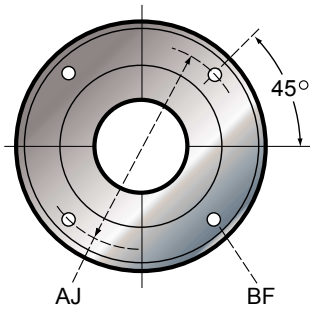

**NEMA FRAMES 182TC-256TC, 254UC/256UC**

**Horizontal Mounting (or Vertical Mounting - Option A)**

MOTOR END DATA		RADIAL CLEARANCE "Z" = 5.00															
AJ	BF	BD	AK	XAK	XAJ2	XBF2	XAJ4	XBF4	MOUNT NO.	CL	M	MOUNT NO.	CL	M	MOUNT NO.	CL	M
7.25	17/32	9.00	8501														
USA4F17	4 Bolt	1.782					2.84	5/16-18	M182474F	4.00	4.75	M182504F	4.31	5.00	M182524F	4.31	5.25
SAE AA	2 Bolt	2.001	3.25	3/8-16					M182472AA	4.00	4.75	M182502AA	4.31	5.00	M182522AA	4.31	5.25
SAE A	2(4) Bolt	3.251	4.19	3/8-16	4.12	3/8-16			M182472A	4.00	4.75	M182502A	4.31	5.00	M182522A	4.31	5.25
80 A2/B4	2(4) Bolt	80.01 mm	109 mm	3/8-16	103 mm	5/16-18			M1824780M	4.00	4.75	M1825080M	4.31	5.00	M1825280M	4.31	5.25
80 S4	4 Bolt	80.01 mm			100 mm	5/16-18			M1824780MS	4.00	4.75	M1825080MS	4.31	5.00	M1825280MS	4.31	5.25
PUMP FLANGE		PUMP END DATA						4.75 LENGTH			5.00 LENGTH			5.25 LENGTH			

MOTOR END DATA		RADIAL CLEARANCE "Z" = 5.00															
AJ	BF	BD	AK	XAK	XAJ2	XBF2	XAJ4	XBF4	MOUNT NO.	CL	M	MOUNT NO.	CL	M	MOUNT NO.	CL	M
7.25	17/32	9.00	8501														
USA4F17	4 Bolt	1.782					2.84	5/16-18	M182584F	5.06	5.81	M182684F	6.06	6.81			
SAE AA	2 Bolt	2.001	3.25	3/8-16					M182582AA	5.06	5.81	M182682AA	6.06	6.81			
SAE A	2(4) Bolt	3.251	4.19	3/8-16	4.12	3/8-16			M182582A	5.06	5.81	M182682A	6.06	6.81			
80 A2/B4	2(4) Bolt	80.01 mm	109 mm	3/8-16	103 mm	5/16-18			M1825880M	5.06	5.81	M1826880M	6.06	6.81			
80 S4	4 Bolt	80.01 mm			100 mm	5/16-18			M1825880MS	5.06	5.81	M1826880MS	6.06	6.81			
PUMP FLANGE		PUMP END DATA						5.81 LENGTH			6.81 LENGTH						

**NEMA FRAMES 182TC-256TC, 254UC/256UC**

**Horizontal Mounting**

MOTOR END DATA		RADIAL CLEARANCE "Z" = 5.00															
AJ	BF	BD	AK	XAK	XAJ2	XBF2	XAJ4	XBF4	MOUNT NO.	CL	M	MOUNT NO.	CL	M	MOUNT NO.	CL	M
7.25	17/32	9.00	8501														
SAE-B	2(4) Bolt	4.001	5.75	1/2-13	5.00	1/2-13			M182522B	4.50	5.25	M182582B	5.06	5.81	M182602B	5.25	6.00
SAE C	2(4) Bolt	5.001	7.12	5/8-11	6.38	1/2-13			M182522C	4.50	5.25	M182582C	5.06	5.81	M182602C	5.25	6.00
100 A2/B4	2(4) Bolt	100.01 mm	140 mm	1/2-13	125 mm	3/8-16			M18252100M	4.50	5.25	M18258100M	5.06	5.81	M18260100M	5.25	6.00
125 A2/B4	2(4) Bolt	125.01 mm	180 mm	5/8-11	160 mm	1/2-13			M18252125M	4.50	5.25	M18258125M	5.06	5.81	M18260125M	5.25	6.00
PUMP FLANGE		PUMP END DATA						5.25 LENGTH			5.81 LENGTH			6.00 LENGTH			

MOTOR END DATA		RADIAL CLEARANCE "Z" = 5.00															
AJ	BF	BD	AK	XAK	XAJ2	XBF2	XAJ4	XBF4	MOUNT NO.	CL	M	MOUNT NO.	CL	M	MOUNT NO.	CL	M
7.25	17/32	9.00	8501														
SAE-B	2(4) Bolt	4.001	5.75	1/2-13	5.00	1/2-13			M182682B	6.06	6.81	M182702B	6.25	7.00			
SAE C	2(4) Bolt	5.001	7.12	5/8-11	6.38	1/2-13			M182682C	6.06	6.81	M182702C	6.25	7.00			
SAE D	2(4) Bolt	6.001	9.00	3/4-10	9.00	3/4-10											
100 A2/B4	2(4) Bolt	100.01 mm	140 mm	1/2-13	125 mm	3/8-16			M18268100M	6.06	6.81	M18270100M	6.25	7.00			
125 A2/B4	2(4) Bolt	125.01 mm	180 mm	5/8-11	160 mm	1/2-13			M18268125M	6.06	6.81	M18270125M	6.25	7.00			
PUMP FLANGE		PUMP END DATA						6.81 LENGTH			7.00 LENGTH			7.50 LENGTH			

Contact Hydro-Craft for quotes on gas engine and steel mounts

All dimensions are approximate in inches



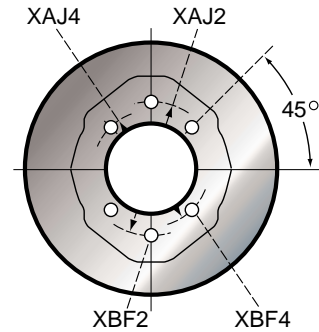
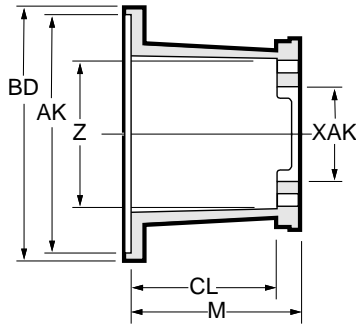
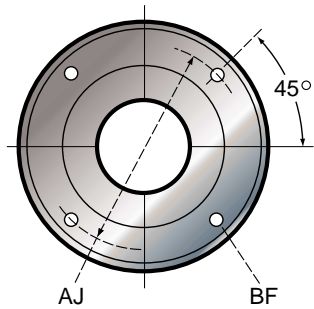

### NEMA FRAMES 284TC/TSC - 286TC/TSC, 284UC/286UC - Horizontal Mounting

MOTOR END DATA		RADIAL CLEARANCE "Z" = 6.40															
AJ	BF	BD	AK	XAK	XAJ2	XBF2	XAJ4	XBF4	MOUNT NO.	CL	M	MOUNT NO.	CL	M	MOUNT NO.	CL	M
9.00	17/32	11.00	10.501														
SAE A	2(4) Bolt			3.25	4.19	3/8-16	4.12	3/8-16	M284682A	6.00	6.88	M284752A	6.62	7.50	M284862A	7.81	8.69
SAE B	2(4) Bolt			4.001	5.75	1/2-13	5.00	1/2-13	M284682B	6.00	6.88	M284752B	6.62	7.50	M284862B	7.81	8.69
SAE C	2(4) Bolt			5.001	7.12	5/8-11	6.38	1/2-13	M284682C	6.00	6.88	M284752C	6.62	7.50	M284862C	7.81	8.69
80 A2/B4	2(4) Bolt			80.01mm	109mm	3/8-16	103mm	5/16-18	M2846880M	6.00	6.88	M2847580M	6.62	7.50	M2848680M	7.81	8.69
80 S4	4 Bolt			80.01mm			100mm	5/16-18	M2846880MS	6.00	6.88	M2847580MS	6.62	7.50	M2848680MS	7.81	8.69
100 A2/B4	2(4) Bolt			100.01mm	140mm	1/2-13	125mm	3/8-16	M28468100M	6.00	6.88	M28475100M	6.62	7.50	M28486100M	7.81	8.69
125 A2/B4	2(4) Bolt			125.01mm	180mm	5/8-11	160mm	1/2-13	M28468125M	6.00	6.88	M28475125M	6.62	7.50	M28486125M	7.81	8.69
PUMP FLANGE	PUMP END DATA			6.88 LENGTH			7.50 LENGTH			8.69 LENGTH							

### NEMA FRAMES 324TC/TSC - 405TC/TSC, 324UC/USC-405UC/USC - Horizontal Mounting

MOTOR END DATA		RADIAL CLEARANCE "Z" = 7.74												
AJ	BF	BD	AK	XAK	XAJ2	XBF2	XAJ4	XBF4	MOUNT NO.	CL	M	MOUNT NO.	CL	M
11.00	2 1/32	14.00	12.501											
SAE B	2(4) Bolt			4.001	5.75	1/2-13	5.00	1/2-13	M324762B	6.75	7.62	M324872B	7.88	8.75
SAE C	2(4) Bolt			5.001	7.12	5/8-11	6.38	1/2-13	M324762C	6.75	7.62	M324872C	7.88	8.75
SAE D	2(4) Bolt			6.001	9.00	3/4-10	9.00	3/4-10	M324762D	6.75	7.62	M324872D	7.88	8.75
100 A2/B4	2(4) Bolt			100.01mm	140mm	1/2-13	125mm	3/8-16	M32476100M	6.75	7.62	M32487100M	7.88	8.75
125 A2/B4	2(4) Bolt			125.01mm	180mm	5/8-11	160mm	1/2-13	M32476125M	6.75	7.62	M32487125M	7.88	8.75
160 A2/B4	2(4) Bolt			160.01mm	224mm	3/4-10	200mm	5/8-11	M32476160M	6.75	7.62	M32487160M	7.88	8.75
180 B4	4 Bolt			180.01mm			224mm	5/8-11	M32476180M	6.75	7.62	M32487180M	7.88	8.75
PUMP FLANGE	PUMP END DATA			7.62 LENGTH			8.75 LENGTH							

### NEMA FRAMES 444TC/TSC - 449TC/TSC, 444UC/USC-445UC/USC - Horizontal Mounting

MOTOR END DATA		RADIAL CLEARANCE "Z" = 10.75											
AJ	BF	BD	AK	XAK	XAJ2	XBF2	XAJ4	XBF4	MOUNT NO.	CL	M		
14.00	2 1/31	18.00	16.001										
SAE C	2(4) Bolt			5.001	7.12	5/8-11	6.38	1/2-13	M444882C	7.12	8.88		
SAE D	2(4) Bolt			6.001	9.00	3/4-10	9.00	3/4-10	M444882D	7.12	8.88		
SAE E	2 Bolt			6.501	12.50	1-8			M444882E	7.12	8.88		
PUMP FLANGE	PUMP END DATA			8.88 LENGTH									

Contact Hydro-Craft for quotes on gas engine and steel mounts

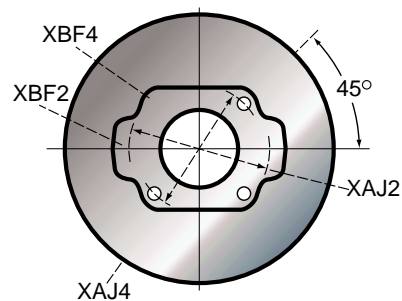
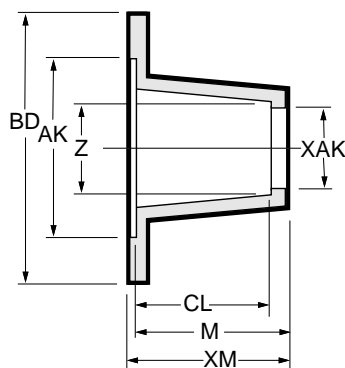
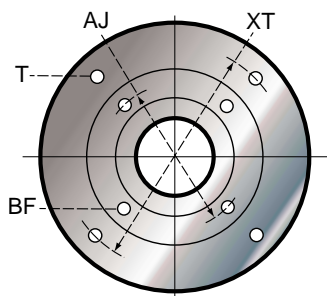

**NEMA FRAMES 56TC, 143TC/145TC, 182TC/256TC, 182UC/184UC, 213UC/256UC**

Vertical Mounting - Option B - Please refer to page 48

MOTOR END DATA		RADIAL CLEARANCE "Z" = 4.15															
AJ	BF	BD	AK														
5.88	7/16	6.81	4.501	XAK	XAJ2	XBF2	XAJ4	XBF4	MOUNT NO.	CL	XM	MOUNT NO.	CL	XM	MOUNT NO.	CL	XM
USA4F17	4 Bolt	1.782		2.84	5/16-18	M056354FV	2.81	3.50	M056424FV	3.56	4.25	M056454FV	3.81	4.50			
SAE AA	2 Bolt	2.001	3.25	3/8-16	M056352AAV	2.81	3.50	M056422AAV	3.56	4.25	M056452AAV	3.81	4.50				
SAE A	2(4) Bolt	3.251	4.19	3/8-16	4.12	3/8-16	M056352AV	2.81	3.50	M056422AV	3.56	4.25	M056452AV	3.81	4.50		
80 A2/B4	2(4) Bolt	80.01mm	109mm	3/8-16	103mm	5/16-18	M0563580MV	2.81	3.50	M0564280MV	3.56	4.25	M0564580MV	3.81	4.50		
80 S4	4 Bolt	80.01mm		100mm	5/16-18	M056580MSV	2.81	3.50	M0564280MSV	3.56	4.25	M0564580MSV	3.81	4.50			
PUMP FLANGE		PUMP END DATA				3.50 LENGTH			4.25 LENGTH			4.50 LENGTH					

MOTOR END DATA		RADIAL CLEARANCE "Z" = 4.10													
AJ	BF	BD	AK												
5.88	7/16	6.81	4.501	XAK	XAJ2	XBF2	XAJ4	XBF4	MOUNT NO.	CL	XM	MOUNT NO.	CL	XM	
USA4F17	4 Bolt	1.782		2.84	5/16-18	M056504FV	3.93	5.00	M056524FV	3.93	5.25				
SAE AA	2 Bolt	2.001	3.25	3/8-16	M056502AAV	3.93	5.00	M056522AAV	3.93	5.25					
SAE A	2(4) Bolt	3.251	4.19	3/8-16	4.12	3/8-16	M056502AV	3.93	5.00	M056522AV	3.93	5.25			
SAE B	2(4) Bolt	4.001	5.75	1/2-13	5.00	1/2-13	M056502BV	3.93	5.00	M056522BV	3.93	5.25			
80 A2/B4	2(4) Bolt	80.01mm	109mm	3/8-16	103mm	5/16-18	M0565080MV	3.93	5.00	M0565280MV	3.93	5.25			
80 S4	4 Bolt	80.01mm		100mm	5/16-18	M0565080MSV	3.93	5.00	M0565280MSV	3.93	5.25				
100 A2/B4	2(4) Bolt	100.01mm	140mm	1/2-13	125mm	3/8-16	M05650100MV	3.93	5.00	M05652100MV	3.93	5.25			
PUMP FLANGE		PUMP END DATA				5.00 LENGTH			5.25 LENGTH						

**Note:** Vertical and horizontal welded steel mounts available. Please contact Hydro-Craft for more information.

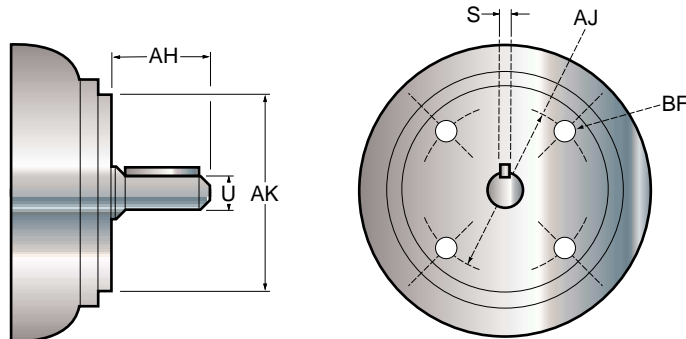

# NEMA 'C' Motor

## U-FRAME DIMENSIONS

	182UC 184UC	213UC 215UC	254UC 256UC	284UC 286UC	324USC 326USC	324UC 326UC	364USC 365USC	364UC 365UC	404USC 405USC	404UC 405UC	444USC 445USC	444UC 445UC
AH	2.125	2.75	3.50	4.625	3.00	5.375	3.50	6.125	4.00	6.875	4.00	8.375
U	7/8	1-1/8	1-3/8	1-5/8	1-5/8	1-7/8	1-7/8	2-1/8	2-1/8	2-3/8	2-1/8	2-7/8
S	3/16	1/4	5/16	3/8	3/8	1/2	1/2	1/2	5/8	5/8	1/2	3/4
AK	4.50	8.50	8.50	10.50	12.50	12.50	12.50	12.50	12.50	12.50	16.00	16.00
AJ	5.875	7.25	7.25	9.00	11.00	11.00	11.00	11.00	11.00	11.00	14.00	14.00
BF	3/8-16	1/2-13	1/2-13	1/2-13	5/8-11	5/8-11	5/8-11	5/8-11	5/8-11	5/8-11	5/8-11	5/8-11
<b>HORSE POWER RATED @ 1750 RPM</b>												
MIN.	1	3	7.5	15	25	25	40	40	60	60	125	125
MAX.	2	5	10	20	30	30	50	50	75	75	150	150

## T-FRAME DIMENSIONS

	056C	143TC 145TC	182TC 184TC	213TC 215TC	254TC 256TC	284TSC 286TSC	284TC 286TC	324TSC 326TSC	324TC 326TC	364TSC 365TSC	364TC 365TC	404TSC 405TSC	404TC 405TC	444TSC 449TSC	444TC 449TC
AH	2.062	2.125	2.625	3.125	3.75	3.00	4.375	3.50	5.00	3.50	5.62	4.00	7.00	4.50	8.25
U	5/8	7/8	1-1/8	1-3/8	1-5/8	1-5/8	1-7/8	1-7/8	2-1/8	1-7/8	2-3/8	2-1/8	2-7/8	2-3/8	3-3/8
S	3/16	3/16	1/4	5/16	3/8	3/8	1/2	1/2	1/2	1/2	5/8	1/2	3/4	5/8	7/8
AK	4.50	4.50	8.50	8.50	8.50	10.50	10.50	12.50	12.50	12.50	12.50	12.50	12.50	16.00	16.00
AJ	5.875	5.875	7.25	7.25	7.25	9.00	9.00	11.00	11.00	11.00	11.00	11.00	11.00	14.00	14.00
BF	3/8-16	3/8-16	1/2-13	1/2-13	1/2-13	1/2-13	1/2-13	5/8-11	5/8-11	5/8-11	5/8-11	5/8-11	5/8-11	5/8-11	5/8-11
<b>HORSE POWER RATED @ 1750 RPM</b>															
MIN.	1/4	1	3	7.5	15	25	25	40	40	60	60	100	100	150	150
MAX.	1/2	2	5	10	20	30	30	50	50	75	75	125	125	200	200

### Cast Aluminum Mounts

CAST ALUMINUM MOUNTS are permanent mold cast of lightweight, high strength aluminum alloy and incorporate many unique design features.

Custom molded OSHA orange coupling access covers are included for mounts larger than motor group size 056.

These covers are quickly and securely retained via a lip-tab on one end and a single self-tapping screw on the other.

Horizontal mounts are supplied with a pre-cast drain hole for residual fluids. This unique feature aids in quick detection of leaky seals and other trouble areas.

Using Hydro-Crafts Mounts ensures a lightweight, high strength, precision mount for efficient assembly, quiet operation, accurate shaft alignment and complete coupling concealment.

### Horizontal Pump/Motor Mounts

Hydro-Crafts HORIZONTAL PUMP/MOTOR MOUNTS are available for mounting NEMA C 'face motors in frame sizes 56C through 449TSC to most SAE and Metric 2 and 4 bolt pump flanges.

A MOUNT KIT is included which contains all bolts and washers required to attach the pump and motor to the mount.

Contact Hydro-Craft for quotes on gas engine and steel mounts

## NEMA FRAME 56C THRU 145TC - Vertical Mounting

### OPTION A

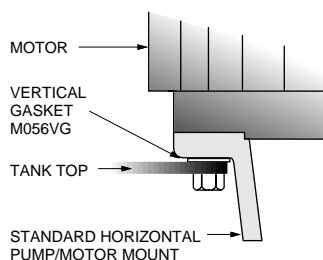
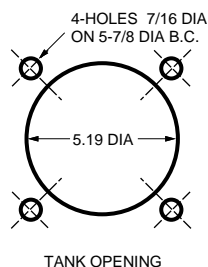

### ILLUSTRATION B

This economical vertical mounting option allows Tank Top Drop-Thru mounting for ease of assembly and utilizes the standard horizontal mount and a sealing gasket.

To order OPTION A, specify the Horizontal Pump/Motor Mount number from page 43 and Vertical Gasket number M056VG.

### OPTION B

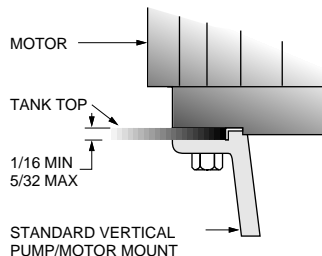
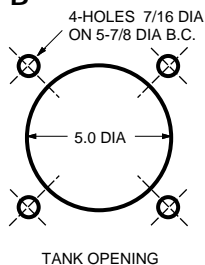

### ILLUSTRATION C

This mounting option requires inside tank access to position the mount/pump sub-assembly through the tank top opening.

To order OPTION B, specify the Vertical Pump/Motor Mount number from page 46 followed with the 'V' as shown on page 46. No gasket is required with this mounting option.

## NEMA FRAME 182TC THRU 256TC - Vertical Mounting

### OPTION A

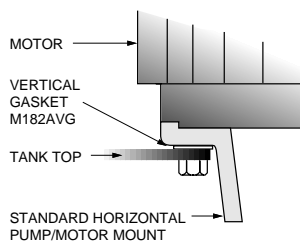
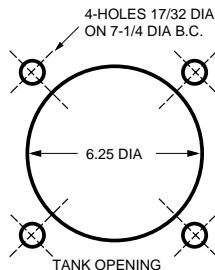

### ILLUSTRATION D

This mounting option offers an economical alternative to OPTION B, but is available only with SAE-A and smaller pump flanges. OPTION A utilizes the standard horizontal mount and a sealing gasket.

To order Option A, specify the Horizontal Pump/Motor Mount number from page 44 and Vertical Gasket number M182AVG.

All dimensions are approximate in inches

# Hydraulic Ball Valves

## 2-WAY BLOCK BODY THREADED

- Carbon steel construction with Zinc Dichromate plating
- 316 stainless steel is available
- Unrestricted bore up to 1" size
- Maximum working pressure of up to 7250 psi
- POM seats and Buna-N o-rings standard on carbon steel valves
- Optional seal material is available for extreme temperature applications and fluid compatibility, contact Hydro-Craft®

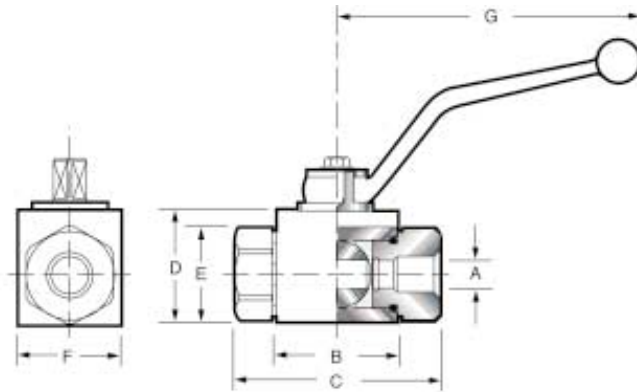

### SPECIFICATIONS

NPT	SAE	PSI MAX	A BORE	B	C	D	E	F	G	WEIGHT LBS
AE2 N1/4	AE2 S#4	7250	.24	1.65	2.80	1.38	.55	1.18	4.33	1.1
AE2 N3/8	AE2 S#6	7250	.39	1.73	2.87	1.57	.67	1.38	4.33	1.4
AE2 N1/2	AE2 S#8	7250	.51	1.89	3.27	1.69	.71	1.46	4.33	1.7
AE2 N3/4	AE2 S#12	5800	.79	2.44	3.74	2.17	.91	1.77	7.09	3.1
AE2 N1	AE2 S#16	5075	.98	2.60	4.45	2.56	1.14	2.17	7.09	4.7
AE2 N1-1/4R	AE2 S#20R	5075	.98	2.60	4.45	2.56	1.14	2.17	7.09	5.0
AE2 N1-1/2R	AE2 S#24R	5075	.98	2.60	4.88	2.56	1.14	2.17	7.09	5.2

### HOW TO ORDER Build an ordering code, as in example below:

EXAMPLE: AE2 N1/2 R 1 1 D B

#### VALVE SERIES

#### CONNECTION TYPE/SIZE

NPT PIPE THREAD = N  
 SAE STRAIGHT THREAD = S  
 BSPP THREAD = B

#### BORE RESTRICTION

UNRESTRICTED BORE = -  
 RESTRICTED BORE = R

#### BODY AND ADAPTER MATERIAL

CARBON STEEL = 1  
 316 STAINLESS STEEL = 2

#### ADAPTER AND STEM SEALS

B = BUNA-N - STANDARD  
 V = VITON - STANDARD ON S/S

#### BALL AND STEM SEATS

D = POM - STANDARD

#### BALL AND STEM MATERIAL

1 = CARBON STEEL  
 2 = 316 STAINLESS STEEL

Locking Kit is available: LK6 1/4"-1/2" LK20 3/4"-2"

All dimensions are approximate in inches

# Hydraulic Ball Valves

## 2-WAY ROUND BODY THREADED



- Carbon steel construction with Zinc Dichromate plating
- 316 stainless steel is available
- Unrestricted bore up to 2" size
- Maximum working pressure of up to 5075 psi
- POM seats and Buna-N o-rings standard on carbon steel valves
- Optional seal material is available for extreme temperature applications and fluid compatibility, contact Hydro-Craft®

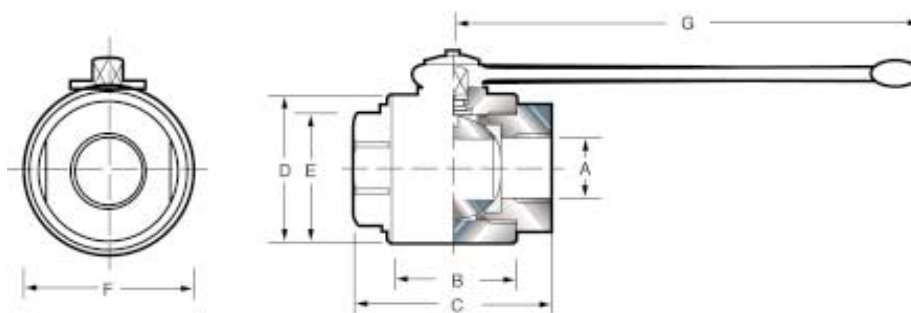

### SPECIFICATIONS

NPT	SAE	PSI MAX	A BORE	B	C	D	E	F	G	WEIGHT LBS
AB2 N1-1/4	AB2 S#20	5075	1.26	4.53	3.74	3.25	1.65	3.46	11.69	8.3
AB2 N1-1/2	AB2 S#24	5075	1.57	5.16	4.25	3.86	1.89	4.02	11.69	12.5
AB2 N2	AB2 S#32	5075	1.97	5.51	4.53	4.06	2.03	4.29	11.69	14.6

### HOW TO ORDER

Build an ordering code, as in example below:

EXAMPLE: AB2 N1-1/2R 1 1 D B

**VALVE SERIES**

**CONNECTION TYPE/SIZE**

- NPT PIPE THREAD = N
- SAE STRAIGHT THREAD = S
- BSPP THREAD = B

**BORE RESTRICTION**

- UNRESTRICTED BORE = -
- RESTRICTED BORE = R

**BODY AND ADAPTER MATERIAL**

- CARBON STEEL = 1
- 316 STAINLESS STEEL = 2

**ADAPTER AND STEM SEALS**

- B = BUNA-N - STANDARD
- V = VITON - STANDARD ON S/S

**BALL AND STEM SEATS**

- D = POM - STANDARD

**BALL AND STEM MATERIAL**

- 1 = CARBON STEEL
- 2 = 316 STAINLESS STEEL

Locking Kit is available: **LK6** 1/4"-1/2" **LK20** 3/4"-2"

All dimensions are approximate in inches



# Hydraulic Ball Valves

## 3-WAY BLOCK BODY THREADED

- Carbon steel construction with Zinc Dichromate plating
- 316 stainless steel is available
- Maximum working pressure of up to 5800 psi
- POM seats and Buna-N o-rings standard on carbon steel valves
- Optional seal material is available for extreme temperature applications and fluid compatibility, contact Hydro-Craft®
- Optional T-Port is available, contact Hydro-Craft

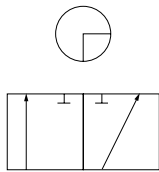

L PORT

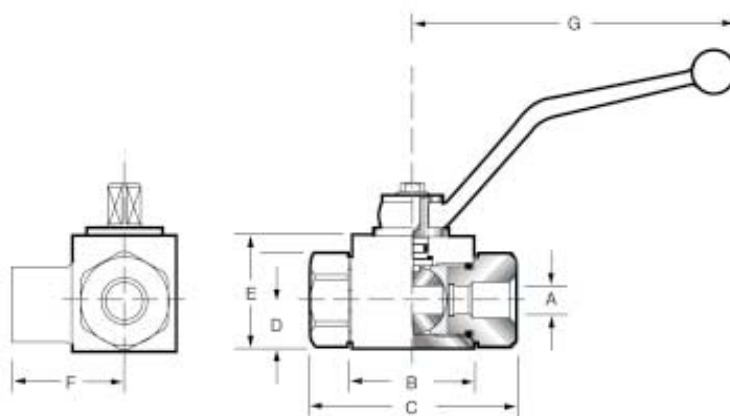

### SPECIFICATIONS

NPT	SAE	PSI MAX	A BORE	B	C	D	E	F	G	H	WEIGHT LBS
AE3L N1/4	AE3L S#4	5800	.24	1.65	2.80	.55	1.38	1.32	1.18	4.31	1.1
AE3L N3/8	AE3L S#6	5800	.39	1.73	2.87	.67	1.57	1.46	1.38	4.31	1.5
AE3L N1/2	AE3L S#8	5075	.51	1.89	3.27	.71	1.69	1.57	1.46	4.31	1.8
AE3L N3/4	AE3L S#12	5075	.79	2.44	3.74	.91	2.17	2.05	1.77	7.00	3.3
AE3L N1	AE3L S#16	5075	.98	2.60	4.45	1.14	2.56	2.36	2.17	7.00	5.2

### HOW TO ORDER

Build an ordering code, as in example below:

EXAMPLE: AE3L N1/2 1 1 D B

**VALVE SERIES**

**PORT TYPE**

DIVERTER L-PORT - STANDARD = L

**CONNECTION TYPE/SIZE**

NPT PIPE THREAD = N

SAE STRAIGHT THREAD = S

**BODY AND ADAPTER MATERIAL**

CARBON STEEL = 1

316 STAINLESS STEEL = 2

**ADAPTER AND STEM SEALS**

B = BUNA-N - STANDARD

V = VITON - STANDARD ON S/S

**BALL AND STEM SEATS**

D = POM - STANDARD

**BALL AND STEM MATERIAL**

1 = CARBON STEEL

2 = 316 STAINLESS STEEL

Locking Kit is available: **LK6** 1/4"-1/2" **LK20** 3/4"-2"

Only pressurize center port. Side ports should not be pressurized or exposed to backpressure that is greater than inlet pressure, as internal leaking through the valve will occur. For applications requiring side port pressure, contact Hydro-Craft.

All dimensions are approximate in inches



## Filter Manifolds

New versatile manifolds from Hydro-Craft® will reduce your build cost and increase your overall flexibility.

- Return filter head with filter and check port (1"x12 threads)
- Gauge ports for filter and working pressure
- Manual filter drain
- Common relief or unloading valve cavity and auxiliary return port
- P & T manifold will accommodate D03 1 to 5 station or D05 single station
- Return manifold may be used in horizontal or vertical applications
- Includes o-ring seals to seal manifold to mating surface
- **CUSTOM ORDER** - Please contact Hydro-Craft

**P and T Version**  
PME-2667A-2

**D03 Bolt-On Manifolds Available**

PME-3279A	- 1 Station
PME-3280A	- 1 Station with Common Cavity
PME-2939A	- 2 Station
PME-1735A	- 2 Station with Common Cavity
PME-3030A	- 3 Station
PME-3058A	- 3 Station with Common Cavity
PME-3054A	- 4 Station
PME-3179A	- 4 Station with Common Cavity
PME-3325A	- 5 Station
PME-3352A	- 5 Station with Common Cavity

**D05 Single-Station Subplate**  
PME-2702A

**D03 Version**  
PME-2685A

# Manifolds

Many standard manifolds are available. We now stock various sizes of cover plates, subplates, tapping plates and parallel manifolds. Hydro-Craft® will inventory our products in the levels necessary to service our customers requirements.

We have the ability to design custom manifolds from a circuit drawing. Hydro-Craft has the engineering and manufacturing capabilities which enable us to manufacture manifolds for most style cartridge valves and DIN cavities. Send as much information and drawings as possible and we will provide a quote to meet your requirements.

If requested, we will engrave your part number in the ® part at no additional charge, for quantities of 100 or more. Please consult us if you have an interest in putting your logo on the part.



## DO3 Parallel Manifold

1*	2	3	4	5	6	7	Number of Stations
2.13	4.25	6.38	8.50	10.63	12.75	14.88	

## DO5 Parallel Manifold

1*	2	3	4	5	6
3.25	6.50	9.75	13.00	16.25	19.50

\*No gauge port available

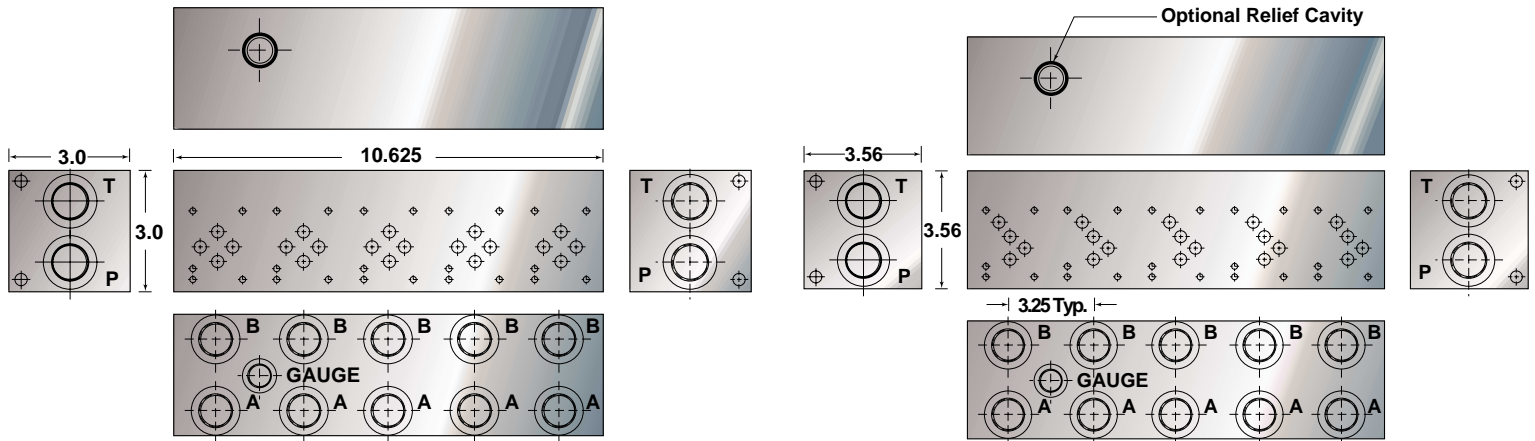

## STANDARD PORT THREADS

	DO3	DO5	DO8	
			P	T
P&T	1= #10 SAE	#12 SAE	#16 SAE	#20 SAE
A&B	1= #8 SAE	#8 SAE	#16 SAE	
GAUGE	1= #6 SAE	#6 SAE	#6 SAE	

Custom threads are available on custom run manifolds, please contact Hydro-Craft for details

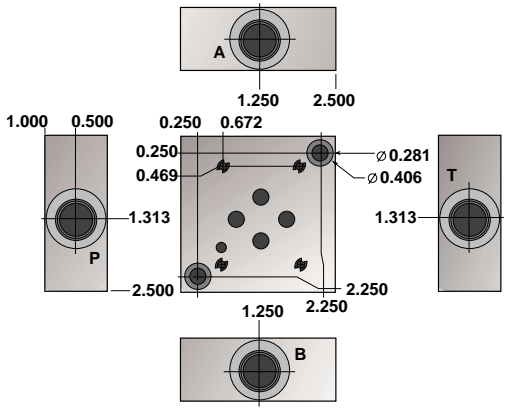

DO3 Subplate

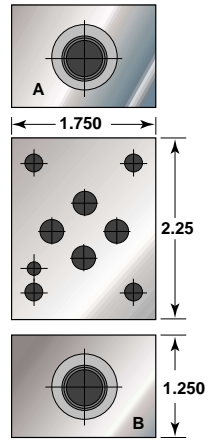

DO3 Tapping Plate

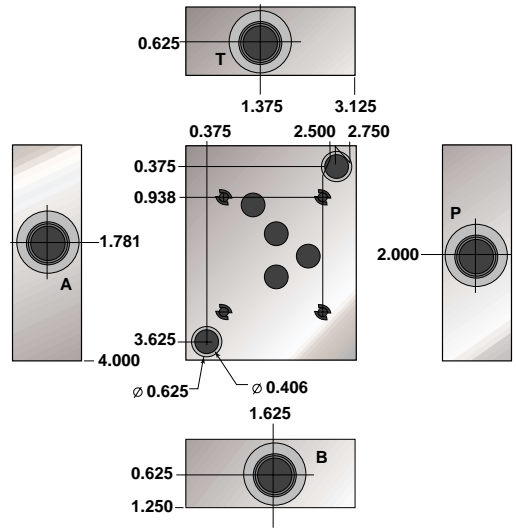

DO5 Subplate

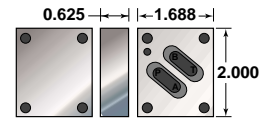

DO3 Crossover

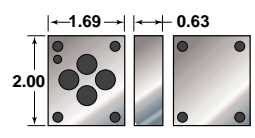

DO3 Cover Plate

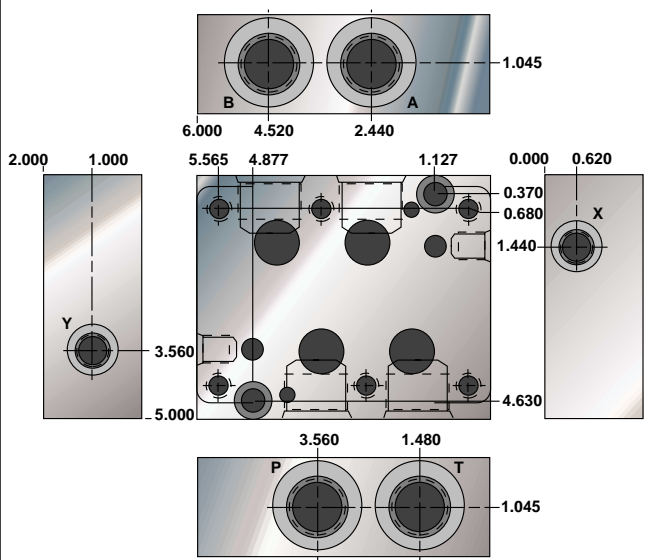

DO8 Subplate

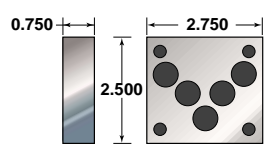

DO5 Cover Plate

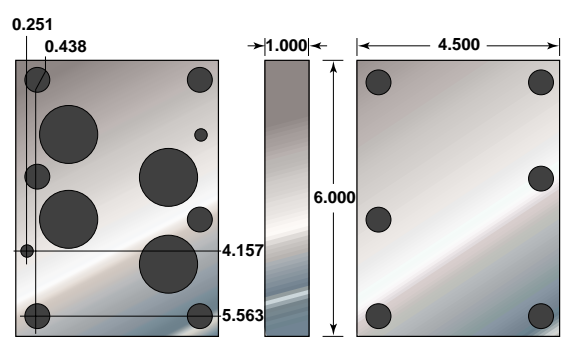

DO8 Cover Plate

# Manifolds

## HOW TO ORDER

Choose part number from the standard list to the right, or select appropriate symbols and build an ordering code, as in examples shown below:

### COVER PLATES

EXAMPLE: HC1 05 - 1

STYLE  
COVER PLATE  
ALUMINUM = HC1

SIZE  
03  
05  
08

TYPE  
PARALLEL CIRCUIT = 1  
CROSSOVER = 2

### PARALLEL MANIFOLDS

EXAMPLE: HC2 05 1-5 3-3-2

STYLE  
PARALLEL CIRCUIT  
ALUMINUM = HC2

SIZE  
03  
05  
08

NO. OF STATIONS  
DO3 = 1-7  
DO5 = 1-5  
DO8 = 1-3

VALVE SPACING  
2.13 (DO3) = 2  
3.25 (DO5) = 3  
5.25 (DO8) = 5

PORT TYPE\*  
SAE = 1  
Customs are available

OPTIONS  
COMMON RELIEF = 1  
SUN CAVITY = 2

### SUBPLATES

EXAMPLE: HC3 05 1-1

STYLE  
SUBPLATE  
ALUMINUM = HC3

SIZE  
03  
05  
08

TYPE  
SIDE PORT = 1

PORTS\*  
SAE = 1

### TAPPING PLATES

EXAMPLE: HC5 05 AB - 1

STYLE  
TAPPING PLATE  
ALUMINUM = HC5

SIZE  
03  
05

TYPE  
AB  
TP  
L

PORTS\*  
SAE = 1

### COVER PLATES ALUMINUM

PART NUMBER	DESCRIPTION
HC103	DO3 Parallel
HC103-2	DO3 Crossover
HC105	DO5 Parallel
HC108	DO8 Parallel

### PARALLEL MANIFOLDS ALUMINUM (SAE ports)

HC20312-1	DO3 Single Sta.
HC20312-1-1	DO3 Single Sta. w/Common Cavity
HC20312-1-2	DO3 Single Sta. w/Sun Cavity
HC20322-1	DO3 2 Sta.
HC20322-1-1	DO3 2 Sta. w/Common Cavity
HC20322-1-2	DO3 2 Sta. w/Sun Cavity
HC20332-1	DO3 3 Sta.
HC20332-1-1	DO3 3 Sta. w/Common Cavity
HC20332-1-2	DO3 3 Sta. w/Sun Cavity
HC20342-1	DO3 4 Sta.
HC20342-1-1	DO3 4 Sta. w/Common Cavity
HC20342-1-2	DO3 4 Sta. w/Sun Cavity
HC20352-1	DO3 5 Sta.
HC20352-1-1	DO3 5 Sta. w/Common Cavity
HC20352-1-2	DO3 5 Sta. w/Sun Cavity
HC20362-1	DO3 6 Sta.
HC20362-1-1	DO3 6 Sta. w/Common Cavity
HC20362-1-2	DO3 6 Sta. w/Sun Cavity
HC20372-1	DO3 7 Sta.
HC20372-1-1	DO3 7 Sta. w/Common Cavity
HC20372-1-2	DO3 7 Sta. w/Sun Cavity
HC20513-1	DO5 Single Sta.
HC20513-1-1	DO5 Single Sta. w/Common Cavity
HC20513-1-2	DO5 Single Sta. w/Sun Cavity
HC20523-1	DO5 2 Sta.
HC20523-1-1	DO5 2 Sta. w/Common Cavity
HC20523-1-2	DO5 2 Sta. w/Sun Cavity
HC20533-1	DO5 3 Sta.
HC20533-1-1	DO5 3 Sta. w/Common Cavity
HC20533-1-2	DO5 3 Sta. w/Sun Capacity
HC20543-1	DO5 4 Sta.
HC20543-1-1	DO5 4 Sta. w/Common Cavity
HC20543-1-2	DO5 4 Sta. w/Sun Cavity
HC20553-1	DO5 5 Sta.
HC20553-1-1	DO5 5 Sta. w/Common Cavity
HC20553-1-2	DO5 5 Sta. w/Sun Cavity

### - CLASS I - SUBPLATES

HC3031-1	DO3 Side Ported SAE
HC3051-1	DO5 Side Ported SAE
HC3081-1	DO8 Side Ported SAE

### - CLASS I - TAPPING PLATES

HC503AB-1	DO3 SAE AB Ports
HC505AB-1	DO5 SAE AB Ports

\*SAE is a stocked item, all other types are special order

**Note:** Please contact Hydro-Craft for updates to manifold standard list.



# Fluid Power Formulas

**AREA**, square inches =  $.7854 \times \text{Diameter Squared}$

**FORCE**, pounds =  $\text{Area} \times \text{PSI}$

**TONNAGE** =  $\frac{\text{Force}}{2000}$

**SPEED**, inches per minute =  $\frac{231 \times \text{GPM}}{\text{Area}}$

**DISPLACEMENT**, cubic inches =  $\text{Area} \times \text{Stroke (inches)}$

**STROKE TIME**, seconds =  $\frac{60 \times \text{Stroke}}{\text{Speed}}$  OR  $\frac{.2598 \times \text{Displacement}}{\text{GPM}}$

**GPM**, gallons per minute =  $\frac{\text{Speed} \times \text{Area}}{231}$  OR  $\frac{60 \times \text{Displacement}}{231 \times \text{Stroke Time}}$

**PSI**, pounds per square inch =  $\frac{\text{Force}}{\text{Area}}$

**HP**, horsepower =  $\frac{\text{GPM} \times \text{PSI} \times 231}{33,000 \times 12}$  OR  $\text{GPM} \times \text{PSI} \times .000583$

(@ 83% efficiency, Pump input HP =  $.7 \times \text{GPM}$ , per 1000 PSI operating pressure)

**RESERVOIR CAPACITY** = Approximately three times pump GPM capacity

**VELOCITY**, feet per second =  $\frac{231 \times \text{GPM}}{12 \times 60 \times \text{Area}}$  OR  $\frac{.3208 \times \text{GPM}}{\text{Area}}$

Pump Inlet Velocity should be less than 4 feet per second.  
 Continuous Flow Velocity should be less than 15 feet per second.  
 Intermittent Flow Velocity should be less than 20 feet per second.  
 Infrequent Flow Velocity should be less than 30 feet per second.

**TORQUE**, foot pounds =  $\frac{\text{PSI} \times \text{Displacement per Revolution, cubic inches}}{2 \times 3.1416 \times 12}$

**HP**, horsepower =  $\frac{\text{Torque} \times \text{RPM}}{5252}$

**ONE HP** =  $33,000 \text{ foot pounds per minute} \times 746 \text{ WATTS} = 42.4 \text{ BTU per minute}$

**ONE GALLON** = 231 cubic inches

**COMPRESSIBILITY OF OIL** = .004 per 1,000 PSI

**OIL WEIGHT** = Approximately 7.5 pounds per gallon



# HYDRO-CRAFT

Products & Accessories

CATALOG  
42



*hydro-craft*



**We Specialize in Custom Fabrication and Private Labeling**







**Ask for the latest Hydro-Craft Line Clamping Systems Catalog**





## HYDRO-CRAFT INC.

Hydro-Craft was established in 1958 in a small shop in Detroit, Michigan as a manufacturer of quality hydraulic tanks. Over the years we have expanded our product line and our facilities. We currently have two state-of-the-art plants located in Rochester Hills, Michigan and Henderson, Nevada. From these two points, we can ship our product conveniently to any location worldwide.

The Hydro-Craft product line includes stock and custom hydraulic reservoirs, filler breather caps, sight level gages, flange kits, shock mounts, pump/motor mounts, manifolds, and many more hydraulic accessories.

The dedication to providing our customers with quality parts and service has only grown stronger over the years. We thank you for your interest in our products.

410 E. Paradise Hills Drive,  
Henderson, NV 89002  
Tel (702) 566-3087  
Fax (702) 566-9285

1821 Rochester Industrial Drive,  
Rochester Hills, Michigan 48309  
Tel (248) 652-8100  
Fax (248) 652-0343

WWW: <http://www.hydro-craft.com>  
E-mail: [sales@hydro-craft.com](mailto:sales@hydro-craft.com)



*hydro-craft*®